

1

2

3

4

5

6

7

E

D

C

B

A

LANDSCAPE LEGEND

- EXISTING ALUMINUM EDGER
- EXISTING TREES TO REMAIN
- EXISTING SHRUBS TO REMAIN
- NEW ACCENT PLANT BEDS (SHRUBS, PERENNIALS, AND ORNAMENTAL GRASSES)
- EXISTING ACCENT PLANT BEDS TO REMAIN
- BENCH
- PLANT POT WITH ANNUAL PLANTINGS BY-OWNER

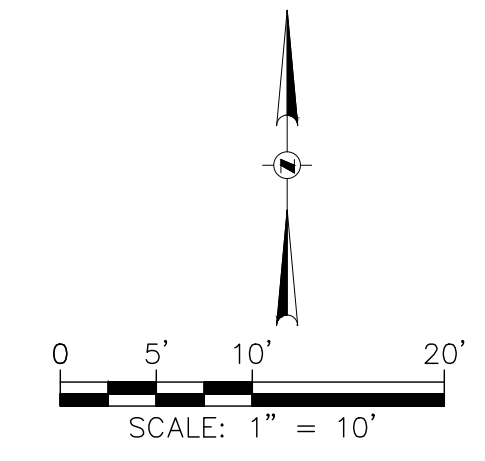

eppstein uhen : architects

milwaukee 333 East Chicago Street
Milwaukee, Wisconsin 53202
414.271.5350

madison 309 West Johnson Street, Suite 202
Madison, Wisconsin 53703
608.442.5350

des moines 699 Walnut Street, Suite 400
Des Moines, Iowa 50309
515.274.5840

denver 1899 Wynkoop Street, Suite 300
Denver, Colorado 80202
303.555.4500

PROJECT INFORMATION

WAUKESHA MEMORIAL HOSPITAL - NORTH WING RENOVATIONS

725 AMERICAN AVENUE, WAUKESHA, WI 53188



ISSUANCE AND REVISIONS

DATE	DESCRIPTION
12/20/2018	PLAN COMMISSION SUBMITTAL

KEY PLAN

SHEET INFORMATION

PROGRESS DOCUMENTS NOT FOR CONSTRUCTION

These documents reflect progress and intent and may be subject to change, including additional detail. These are not final construction documents and shall not be used for final bidding or construction-related purposes.

PROJECT MANAGER

PROJECT NUMBER 418190

LANDSCAPE PLAN

L100

© Eppstein Uhen Architects, Inc.

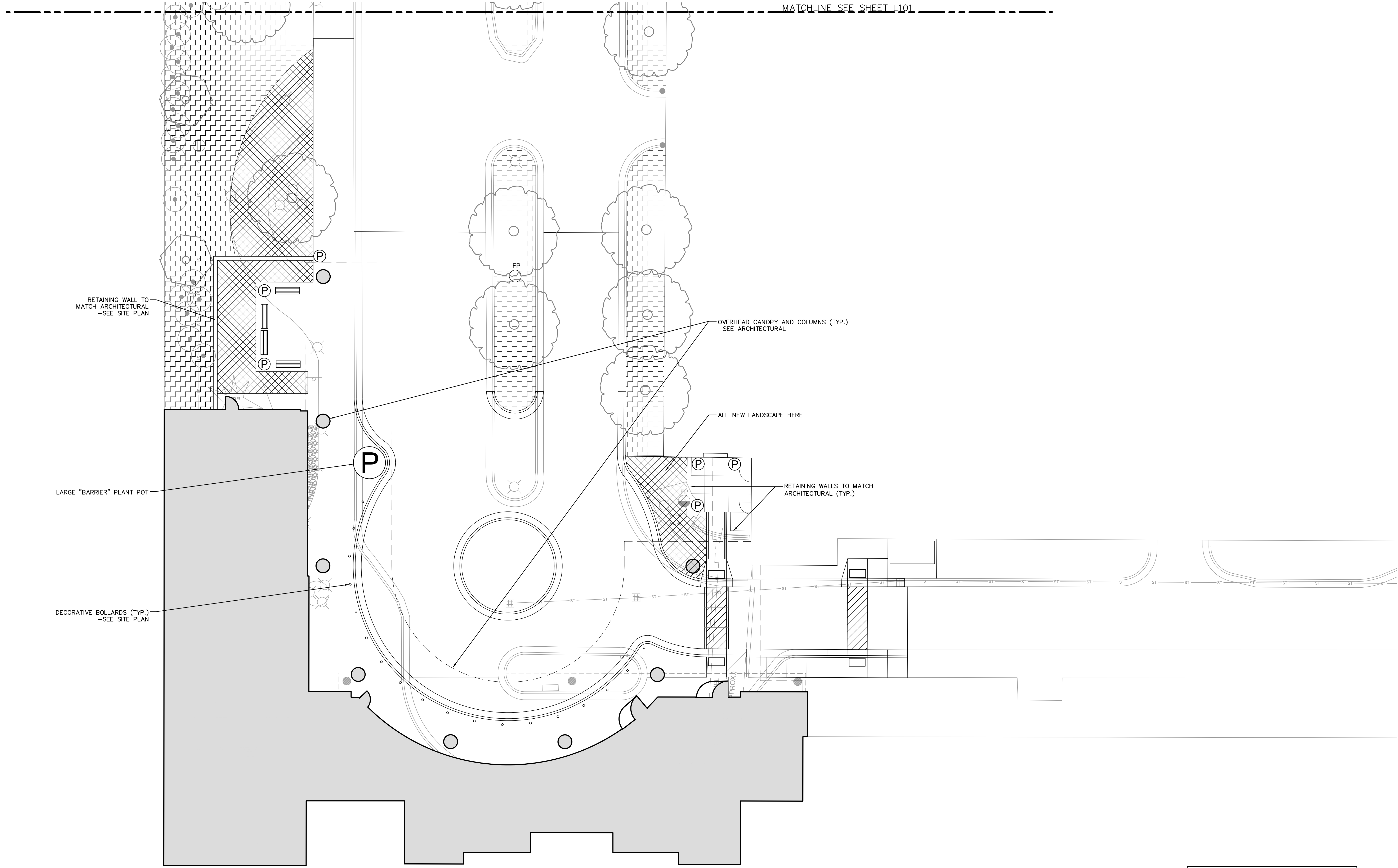

RETAINING WALL TO MATCH ARCHITECTURAL -SEE SITE PLAN

OVERHEAD GANOPY AND COLUMNS (TYP.) -SEE ARCHITECTURAL

ALL NEW LANDSCAPE HERE

RETAINING WALLS TO MATCH ARCHITECTURAL (TYP.)

LARGE "BARRIER" PLANT POT

DECORATIVE BOLLARDS (TYP.) -SEE SITE PLAN

NOTICE:
In accordance with Wisconsin statute 182.0175, damage to transmission facilities, excavator shall be solely responsible to provide advance notice to the designated "ONE-CALL SYSTEM" not less than three working days prior to commencement of any excavation required to perform work contained on this drawing, and further, excavator shall comply with all other requirements of this statute relative to excavator's work.

DISCLAIMER:
The underground utilities shown have been located from field survey information and existing drawings. GRAEF makes no guarantee that the underground utilities shown comprise all such utilities in the area, either in service or abandoned. GRAEF further does not warrant that the underground utilities shown are in the exact location indicated. GRAEF has not physically located the underground utilities.

PROPOSED LANDSCAPE IMPROVEMENTS & EXTENTS

X:\ML\2018\20180420\CAD\Site\dwg\00C_00_L100_Landscape Plan_420 12/19/2018 4:49 PM