

SPECIFICATION NOTE:
SEE SHEET C0.1 FOR PLAN SPECIFICATIONS AND REQUIREMENTS

NOTE:
PROPERTY LINES AND EASEMENTS SHOWN ON THIS SURVEY WERE DRAFTED FROM INFORMATION CONTAINED IN TITLE COMMITMENT FILE NO. 2309A0071, BY WISCONSIN TITLE SERVICE COMPANY, DATED AUGUST 22, 2023 AND IN TITLE COMMITMENT FILE NO. 23-72364, BY FIRST AMERICAN TITLE INSURANCE COMPANY, DATED JUNE 6, 2023. AN UPDATED PLAN OF SURVEY, CERTIFIED SURVEY MAP OR ALTA SURVEY HAS NOT BEEN AUTHORIZED AND THE PROPERTY LINES SHOWN ON THIS PLAN MAY BE INCOMPLETE OR IN ERROR.

NOTE:
SURFACE INDICATIONS OF UTILITIES ALONG WITH DIGGER'S HOTLINE MARKINGS PER TICKET NO. 20233405265 AND NO. 20233405270 HAVE BEEN SHOWN. SIZES AND ELEVATION OF UNDERGROUND UTILITIES SHOWN HEREON ARE BASED ON FIELD MEASUREMENTS OF VISIBLE STRUCTURES IN COMBINATION WITH AVAILABLE DATA PROVIDED TO EXCEL ENGINEERING. EXCEL ENGINEERING MAKES NO GUARANTEE THAT ALL THE EXISTING UTILITIES IN THE SURVEYED AREA HAVE BEEN SHOWN NOR THAT THEY ARE IN THE EXACT LOCATION INDICATED. CONTRACTOR SHALL BE RESPONSIBLE FOR VERIFYING THE LOCATION OF ALL UTILITIES PRIOR TO CONSTRUCTION.

CITY OWNED ELECTRICAL NOTE:
THERE IS CITY OWNED FIBER AND STREETLIGHTING IN THE RIGHT-OF-WAY AND EXISTING PARKING LOT. THE CITY CAN REMOVE THE ONE CITY OWNED LIGHT POLE IN THE LOT PRIOR TO CONSTRUCTION AND ABANDON EXISTING UNDERGROUND WIRING. OWNER/DEVELOPER TO REMOVE CONCRETE BASE. IF ANY STREETLIGHT OR FIBER FACILITY IN THE RIGHT-OF-WAY NEEDS REPAIRS / RELOCATION DUE TO CONSTRUCTION, THE DEVELOPER/OWNER WILL BE RESPONSIBLE FOR ALL COSTS. ALL WORK TO BE COMPLETED PER CITY STANDARD SPECIFICATIONS AND SUBJECT TO INSPECTION FROM THE ENGINEERING DIVISION OF DPW. ANY QUESTIONS OR CONCERNS, CONTACT JEFFREY HERNKE JHERNKE@WAUKESHA-WI.GOV.

NOTE:
CONTRACTOR TO REMOVE ALL EXISTING SITE FEATURES AS NECESSARY TO CONSTRUCT PROPOSED PROJECT. PROTECT ALL EXISTING UTILITIES SCHEDULED TO REMAIN.

UTILITY ABANDONMENT NOTE:
EXISTING SANITARY LATERALS TO BE ABANDONED AT THE MAIN BY INSTALLING A SEGMENTAL CURED-IN-PLACE LINER OVER THE CONNECTION. FIELD VERIFY LOCATION AND ABANDON PER CITY STANDARDS.

ANY EXISTING WATER SERVICES TO THE EXISTING OR PROPOSED COMBINED PARCEL MUST BE PROPERLY ABANDONED IN THE STREET AT THE WATER MAIN BY CUTTING AND CAPPING AT THE MAIN. THE OWNER IS RESPONSIBLE FOR COSTS.

NOTE:
CONTRACTOR TO REMOVE ALL EXISTING SITE FEATURES AS NECESSARY TO CONSTRUCT PROPOSED PROJECT. PROTECT ALL EXISTING UTILITIES SCHEDULED TO REMAIN.

CONTRACTOR TO ENSURE POSITIVE DRAINAGE OF EXISTING STORM SEWER WHICH FLOWS THROUGH THE SITE FROM NEIGHBORING PROPERTY. ENSURE NEW STORM SEWER ROUTING IS FUNCTIONING PRIOR TO REMOVAL OF THE EXISTING DRAINAGE PIPE WHICH FLOWS SOUTH TO WISCONSIN AVE.

CAUTION! CONTRACTOR TO COORDINATE REMOVAL AND RELOCATION OF EXISTING ELECTRICAL SERVICE WITH UTILITY PROVIDER.

CAUTION! CONTRACTOR TO COORDINATE REMOVAL AND RELOCATION OF EXISTING DRY UTILITY SERVICES WITH UTILITY PROVIDERS.

CONTRACTOR TO ENSURE POSITIVE DRAINAGE OF EXISTING STORM SEWER WHICH FLOWS THROUGH THE SITE FROM NEIGHBORING PROPERTY. ENSURE NEW STORM SEWER ROUTING TO CLINTON STREET ROW IS FUNCTIONING PRIOR TO REMOVAL OF THE EXISTING DRAINAGE PIPE WHICH FLOWS TO WISCONSIN AVE ROW.

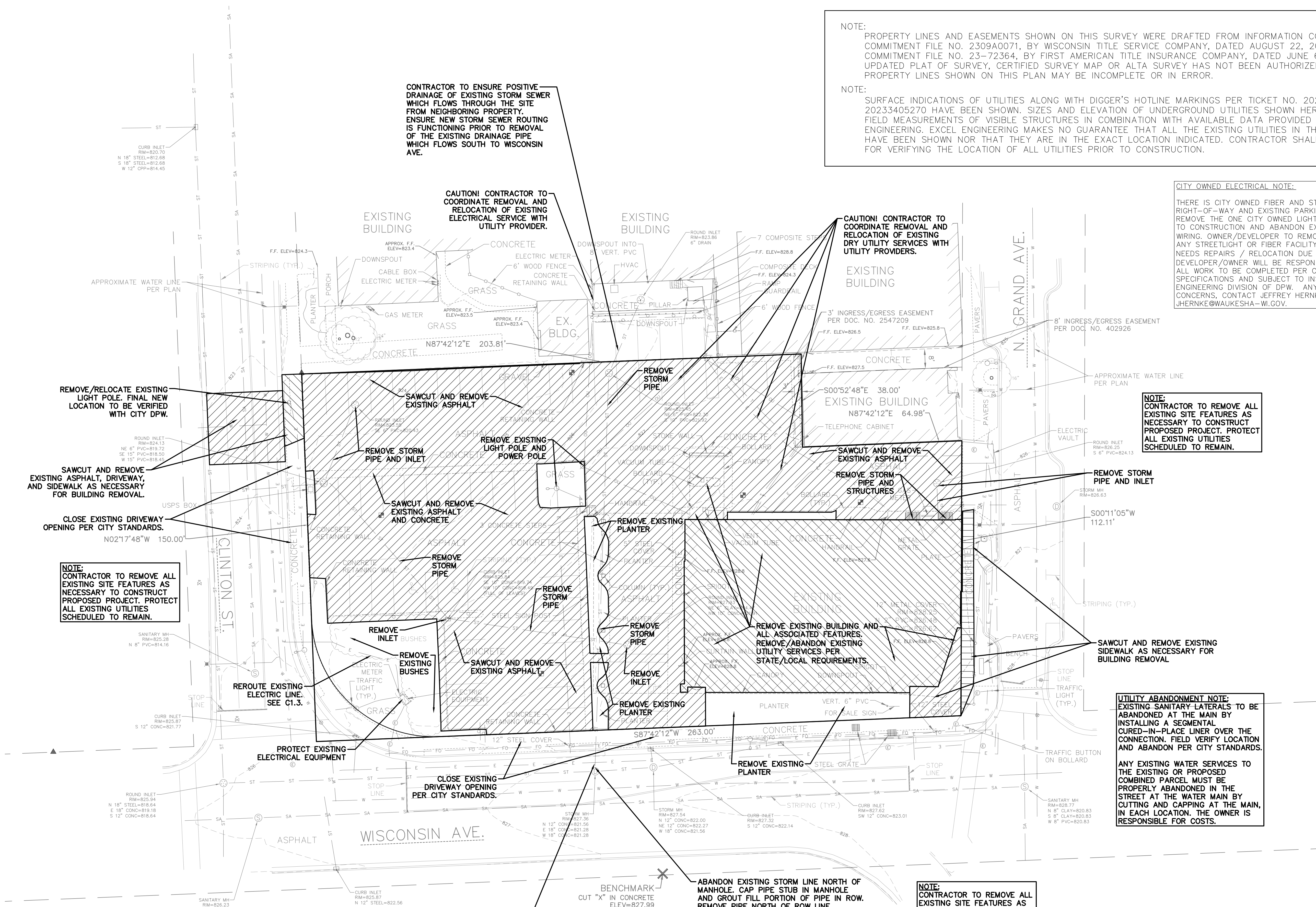

EXCEL
Always a Better Plan
100 Camelot Drive
Fond du Lac, WI 54935
920-926-9800
excelengineer.com

COLLABORATION
BM
BriMark
Builders, LLC

PROJECT INFORMATION

NEW HOTEL FOR:
COBBLESTONE HOTEL AND SUITES
WISCONSIN AVE & N GRAND AVE. • WAUKESHA, WI

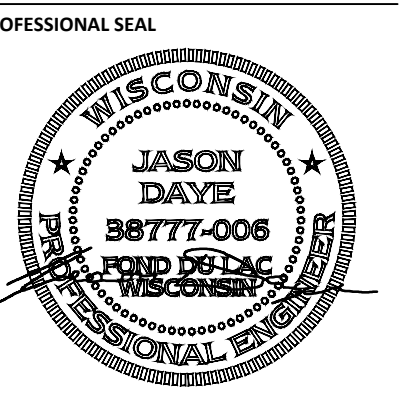

PRELIMINARY DATES
OCT. 10, 2023
NOV. 1, 2023

NOT FOR CONSTRUCTION

JOB NUMBER
2269000

SHEET NUMBER

C1.0

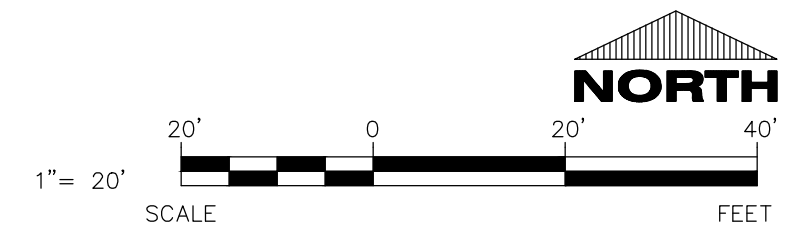

**SPECIFICATION NOTE:
SEE SHEET C0.1 FOR PLAN
SPECIFICATIONS AND REQUIREMENTS**

EXISTING SITE DATA			
	AREA (AC)	AREA (SF)	RATIO
PROJECT SITE	0.86	37,455	
BUILDING FLOOR AREA	0.18	7,770	20.7%
PAVEMENT (ASP. & CONC.)	0.57	24,967	66.7%
TOTAL IMPERVIOUS	0.75	32,737	87.4%
LANDSCAPE/ OPEN SPACE	0.11	4,718	12.6%

PROPOSED SITE DATA			
	AREA (AC)	AREA (SF)	RATIO
PROJECT SITE	0.86	37,455	
BUILDING FLOOR AREA	0.21	9,236	24.7%
PAVEMENT (ASP. & CONC.)	0.41	18,050	48.2%
TOTAL IMPERVIOUS	0.63	27,286	72.9%
LANDSCAPE/ OPEN SPACE	0.23	10,169	27.1%

SITE INFORMATION:

PROPERTY AREA: 37,455 S.F. (0.86 ACRES).
 EXISTING ZONING: B-2 (CENTRAL BUSINESS DISTRICT)
 PROPOSED ZONING: B-2 (CENTRAL BUSINESS DISTRICT)
 PROPOSED USE: COBBLESTONE HOTEL WITH CHOP HOUSE (RESTAURANT)
 AREA OF SITE DISTURBANCE: 0.84 ACRES

SETBACKS: BUILDING: FRONT = 1'
 SIDE/REAR = 0'
 STREET = 1'

PARKING: FRONT = 15' (REDUCED TO 10' W/ LANDSCAPING)
 SIDE = 5'
 STREET = 15' (REDUCED TO 10' W/ LANDSCAPING)

PROPOSED BUILDING HEIGHT: 48' (MAX. HEIGHT ALLOWED: N/A)

PARKING REQUIRED: 1 SPACE PER ROOM + 1/2 PER EMPLOYEE + 1/3 OF MAX CAPACITY OF MEETING/BANQUET SPACE (106 SPACES REQ.)

PARKING PROVIDED: 20 SPACES (1 H.C. ACCESSIBLE) REMAINDER TO USE PUBLIC PARKING GARAGE

HANDICAP STALLS REQUIRED: 1, HANDICAP STALLS PROVIDED: 1



Always a Better Plan

100 Camelot Drive
 Fond du Lac, WI 54935
 920-926-9800
 excelengineer.com



PROJECT INFORMATION

NEW HOTEL FOR:
COBBLESTONE HOTEL AND SUITES
 WISCONSIN AVE & N GRAND AVE. • WAUKESHA, WI

PROFESSIONAL SEAL



PRELIMINARY DATES

OCT. 10, 2023
 NOV. 1, 2023

NOT FOR CONSTRUCTION

JOB NUMBER

2269000

SHEET NUMBER

C1.1

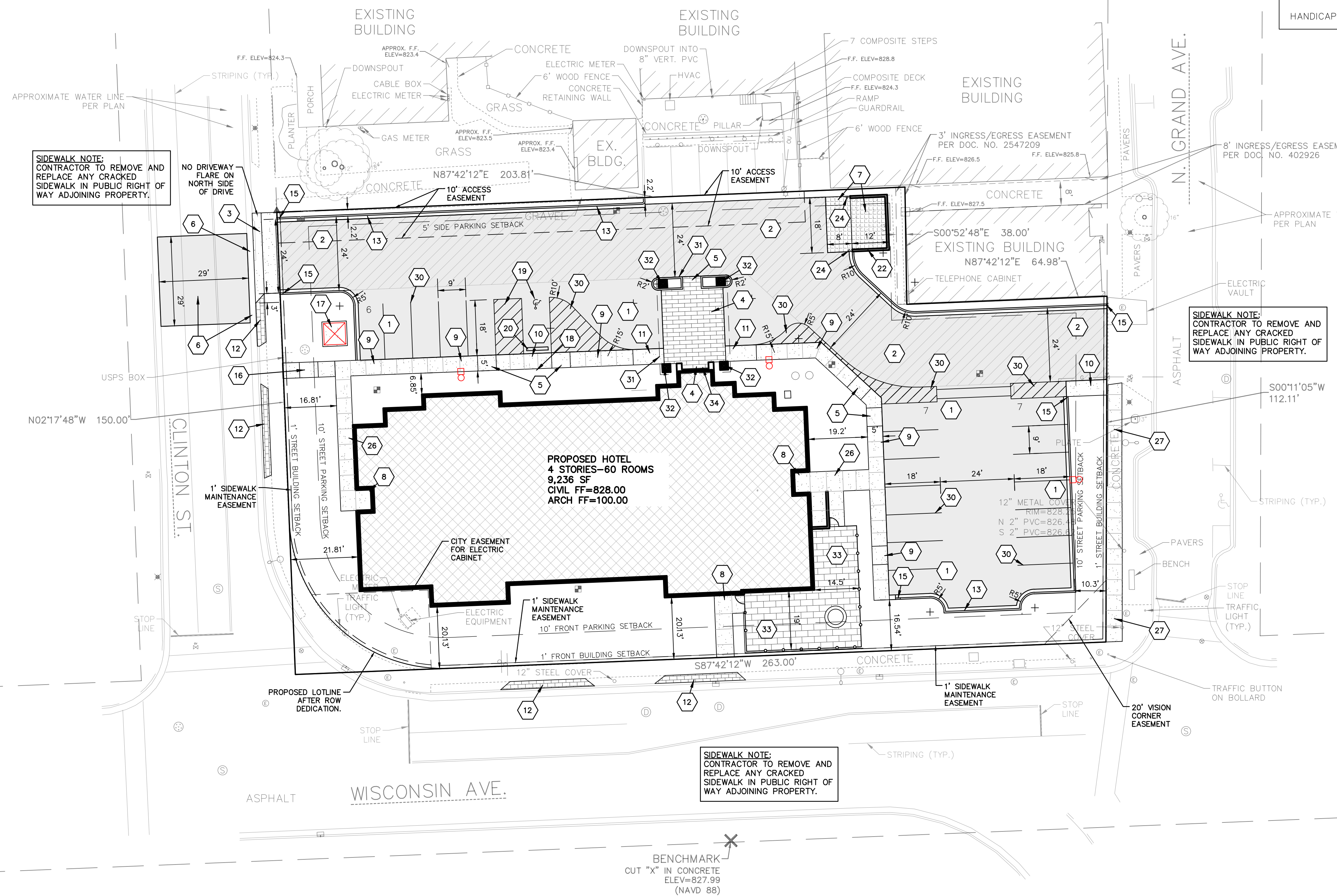

SITE PLAN KEYNOTES

- 1 STANDARD PAVEMENT SECTION (TYP.) (SEE PAVING SECTION TABLE)
 - 2 HEAVY DUTY PAVEMENT SECTION (TYP.) (SEE PAVING SECTION TABLE)
 - 3 PROPOSED NEW CONCRETE DRIVEWAY PER CITY STANDARDS AND SPECIFICATIONS
 - 4 STAMPED LIGHT DUTY CONCRETE (TYP.)
 - 5 HANDICAP RAMP
 - 6 REPLACE EXISTING ASPHALT PAVEMENT AND CURB WITHIN ROW PER CITY STANDARDS AND SPECIFICATIONS. (TYP)
 - 7 DUMPSTER PAD/APRON CONCRETE (TYP)
 - 8 CONCRETE STOOP (TYP.) SEE ARCH. PLANS FOR DETAILS.
 - 9 THICKENED EDGE CONCRETE SIDEWALK (TYP.) (SEE DETAIL)
 - 10 FLUSH CONCRETE WALK (TYP.)
 - 11 WARP ASPHALT UP 6" IN 10' (FLUSH). SEE SHEET C1.2 FOR ELEVATIONS.
 - 12 CLOSE EXISTING DRIVEWAY PER CITY STANDARDS AND SPECIFICATIONS. PROVIDE STAMPED CONCRETE IN TERRACE PER CITY STANDARDS. (TYP)
 - 13 18" CURB & GUTTER (TYP.)
 - 15 CURB TAPER (TYP.)
 - 16 SIDEWALK WITH STEPS. SEE C1.2 FOR STEP ELEVATIONS.
 - 17 CONCRETE TRANSFORMER PAD BY UTILITY SUPPLIER (CONTRACTOR TO VERIFY FINAL LOCATION & DESIGN PRIOR TO CONSTRUCTION)
 - 18 HANDICAP SIGN (3 TYP.)
 - 19 HANDICAP STALL & STRIPING PER STATE CODES. (TYP.)
 - 20 PRECAST CONCRETE WHEEL STOP
 - 21 GROUND MOUNTED REFRIGERATION UNIT (20" TALL)
 - 22 DUMPSTER ENCLOSURE (SEE ARCH PLANS FOR DETAILS)
 - 24 6" CONCRETE BOLLARDS (SEE DETAIL ON ARCH. PLAN)
 - 26 CONCRETE SIDEWALK (TYP)
 - 27 CONCRETE SIDEWALK PER CITY STANDARDS (TYP)
 - 30 PAINTED PAVEMENT STRIPING. (TYP)
 - 31 CANOPY. (SEE ARCH PLANS)
 - 32 COLUMN (TYP.) (SEE ARCH/STRUCT PLANS)
 - 33 4" CONCRETE PATIO W/ FENCE. SEE ARCH PLANS FOR FENCE SPECIFICATION. (TYP.) (FIREPIT ON PATIO FOR FUTURE USE)
 - 34 KNOX BOX LOCATION (TYP.)
- (X(X)) IDENTIFICATION: KEYNOTE ITEM(QUANTITY) - IF NO () = QUANTITY IS 1

PAVING SECTIONS:

BRIMARK STANDARD PAVING BASED UPON GEOTECHNICAL REPORT:
 STANDARD ASPHALT: 3.5 INCHES ASPHALTIC CONCRETE OVER 8 INCHES CRUSHED AGGREGATE BASE.
 HEAVY DUTY ASPHALT: 4 INCHES ASPHALTIC CONCRETE OVER 9 INCHES CRUSHED AGGREGATE BASE.

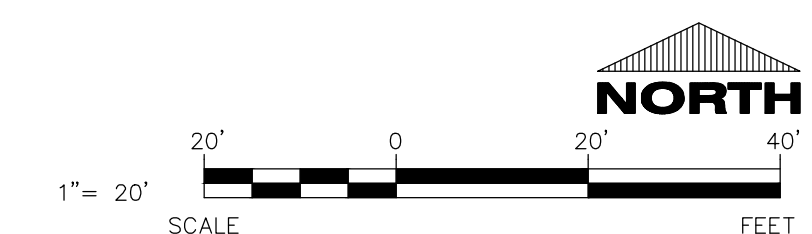

CIVIL SITE PLAN

PROJECT INFORMATION

NEW HOTEL FOR:
COBBLESTONE HOTEL AND SUITES
 WISCONSIN AVE & N GRAND AVE. • WAUKESHA, WI

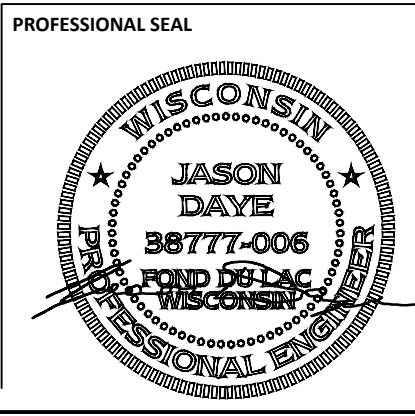

PRELIMINARY DATES

SEPT. 18, 2023
OCT. 10, 2023
NOV. 1, 2023

NOT FOR CONSTRUCTION

JOB NUMBER
 2269000

SHEET NUMBER
C1.2

SPECIFICATION NOTE:
 SEE SHEET C0.1 FOR PLAN SPECIFICATIONS AND REQUIREMENTS

NOTES:

- HANDICAP STALL AND ACCESS AISLES SHALL NOT EXCEED A SLOPE OF 1.50% IN ANY DIRECTION. HANDICAP STALL & ACCESS AISLES SHALL CONFORM TO ADA REQUIREMENTS (CURRENT EDITION)
- ALL SIDEWALKS SHALL NOT EXCEED A MAXIMUM CROSS SLOPE OF 1.50% AND RUNNING SLOPE OF 4.50% UNLESS OTHERWISE SPECIFIED.

INLET PROTECTION NOTE:

IP CONTRACTOR SHALL PROVIDE TEMPORARY INLET PROTECTION FOR ALL CURB INLETS & CATCH BASINS ONSITE & OFFSITE IMMEDIATELY DOWNSTREAM OF THE PROJECT SITE PER LOCAL CODE.

STABILIZED CONSTRUCTION ENTRANCE NOTE:

CONTRACTOR SHALL PROVIDE STABILIZED CONSTRUCTION ENTRANCE AT CONSTRUCTION ENTRANCE FOR PROPOSED IMPROVEMENTS AS REQUIRED PER CODE.

CONCRETE WASHOUT NOTE:

CONTRACTOR SHALL PROVIDE CONCRETE WASHOUT AS REQUIRED PER CODE. FINAL LOCATION TBD BY CONTRACTOR.

RECEIVING WATERS:
 FOX RIVER

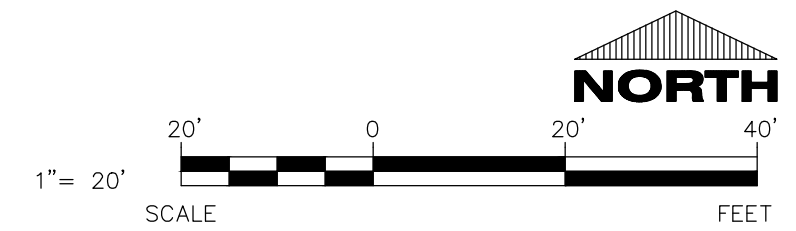
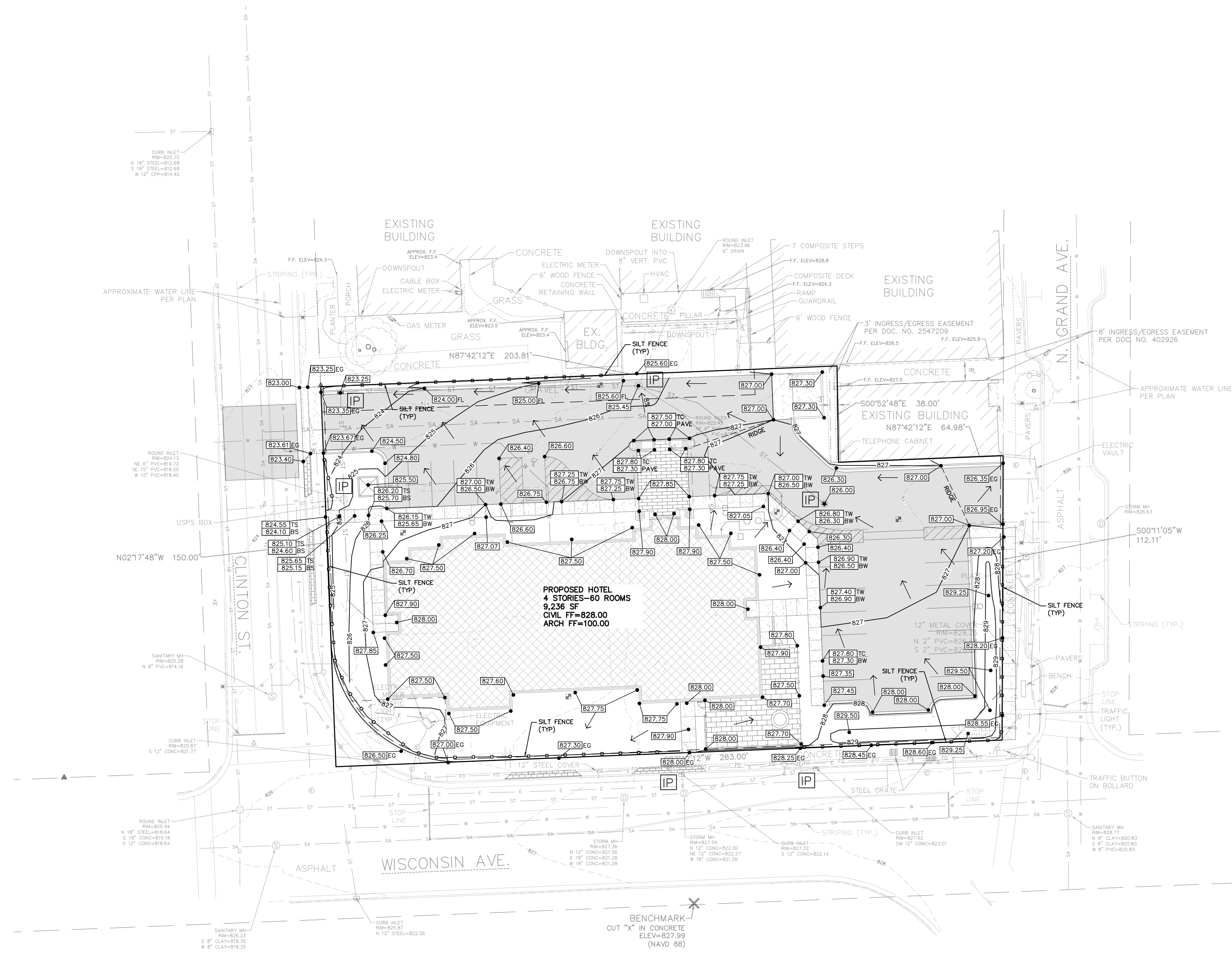

SPECIFICATION NOTE:
SEE SHEET C0.1 FOR PLAN SPECIFICATIONS AND REQUIREMENTS

CLEANOUT NOTE:
[CO] = DENOTES LOCATIONS WHERE CONTRACTOR SHALL INSTALL CLEANOUTS, SEE C0.1 FOR SPECIFICATION.

DOWNSPOUT NOTE:
[DS] = DENOTES DOWNSPOUT TO GRADE LOCATIONS. PROVIDE SPLASH BLOCKS AT ALL DS TO GRADE LOCATIONS. SEE ARCH PLANS FOR FINAL LOCATIONS.

ASBUILT NOTE:
RECORD DRAWING OF THE SANITARY/STORM SEWER FACILITIES SEALED BY A PROFESSIONAL ENGINEER OR REGISTERED LAND SURVEYOR SHALL BE SUBMITTED TO THE CITY OF WAUKESHA ENGINEERING DIVISION.

CONTRACTOR TO CONTACT EXCEL ENGINEERING TO COMPLETE ASBUILT SURVEY ONCE THE REQUIRED IMPROVEMENTS ARE COMPLETE.

- AT A MINIMUM THE DRAWING SHOULD INCLUDE:
- RIM/COVER ELEVATION
 - INVERT ELEVATION
 - DISTANCES
 - SLOPES
 - MATERIALS
 - CONTRACTOR
 - INSTALLATION DATES (MONTH AND YEAR COMPLETED)
 - ANY NOTES RELATED TO MAJOR FIELD CHANGES (IE ADDITIONAL/DELETED STRUCTURES, ETC)
 - SIGNED AND SEALED BY PROFESSIONAL ENGINEER OR REGISTERED LAND SURVEYOR
 - AUTOCAD DRAWING FOR IMPORTING INTO GIS

A REDLINED COPY OF THE PLANS WITH THE PROPOSED INFORMATION CROSSED OUT AND THE ACTUAL CONSTRUCTED INFORMATION NEXT TO IT IS ACCEPTABLE.

A VIDEO OF THE COMPLETED SANITARY LATERAL FROM THE BUILDING TO THE MAINLINE SEWER SHALL BE SUBMITTED TO THE ENGINEERING DIVISION. CONTRACTOR TO COMPLETE THIS UTILITY CAMERA/VIDEOING AND SEND TO EXCEL ENGINEERING FOR SUBMISSION TO CITY.

CITY OWNED ELECTRICAL NOTE:

THERE IS CITY OWNED FIBER AND STREETLIGHTING IN THE RIGHT-OF-WAY AND EXISTING PARKING LOT. THE CITY CAN REMOVE THE ONE CITY OWNED LIGHT POLE IN THE LOT PRIOR TO CONSTRUCTION AND ABANDON EXISTING UNDERGROUND WIRING. OWNER/DEVELOPER TO REMOVE CONCRETE BASE. IF ANY STREETLIGHT OR FIBER FACILITY IN THE RIGHT-OF-WAY NEEDS REPAIRS / RELOCATION DUE TO CONSTRUCTION, THE DEVELOPER/OWNER WILL BE RESPONSIBLE FOR ALL COSTS. ALL WORK TO BE COMPLETED PER CITY STANDARD SPECIFICATIONS AND SUBJECT TO INSPECTION FROM THE ENGINEERING DIVISION OF DPW. ANY QUESTIONS OR CONCERNS, CONTACT JEFFREY HERNKE JHERNKE@WAUKESHA-WI.GOV.

UTILITY ABANDONMENT NOTE:
EXISTING SANITARY LATERALS TO BE ABANDONED AT THE MAIN BY INSTALLING A SEGMENTAL CURED-IN-PLACE LINER OVER THE CONNECTION. FIELD VERIFY LOCATION AND ABANDON PER CITY STANDARDS.

ANY EXISTING WATER SERVICES TO THE EXISTING OR PROPOSED COMBINED PARCEL MUST BE PROPERLY ABANDONED IN THE STREET AT THE WATER MAIN BY CUTTING AND CAPPING AT THE MAIN, IN EACH LOCATION. THE OWNER IS RESPONSIBLE FOR COSTS.

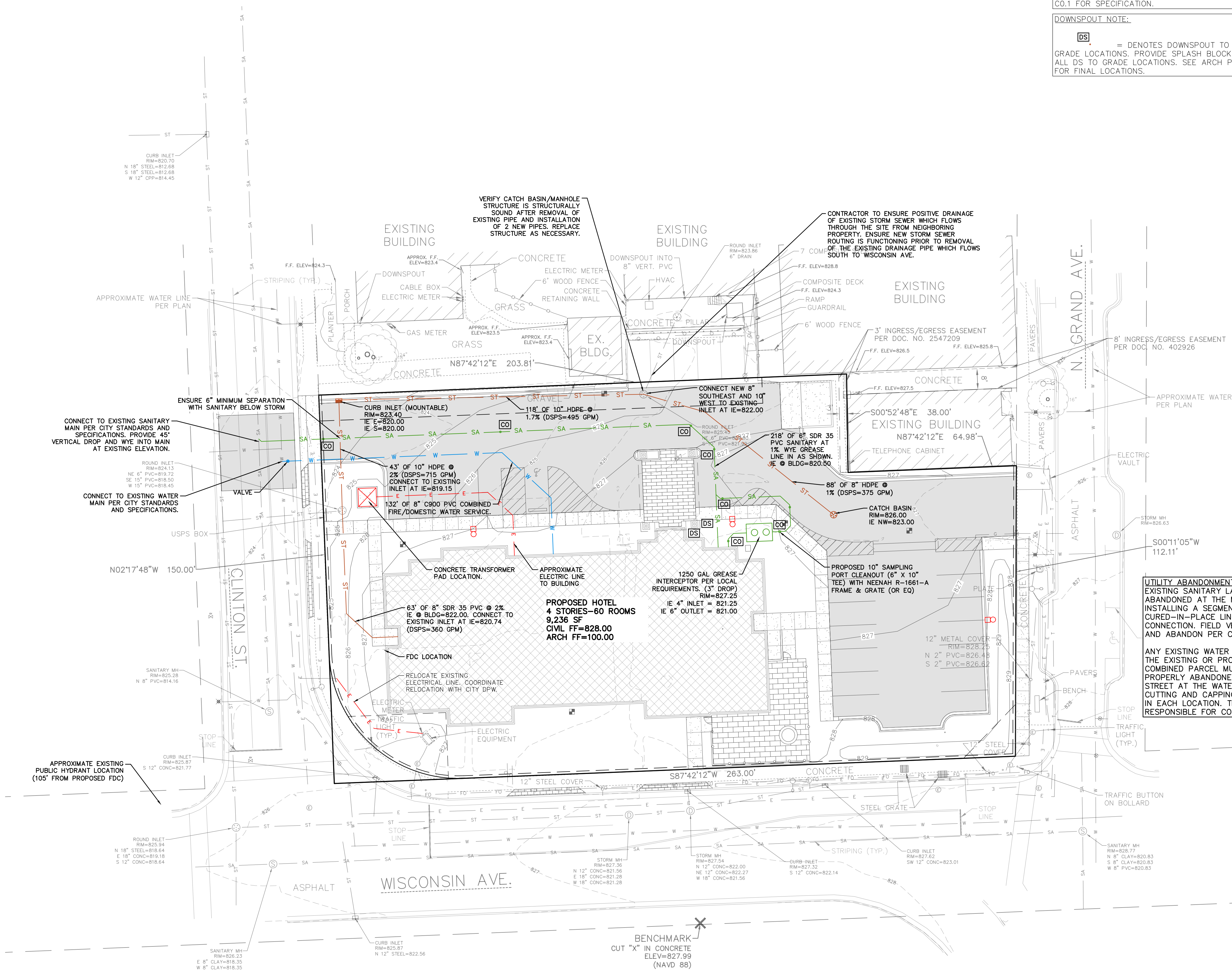

EXCEL
Always a Better Plan
100 Camelot Drive
Fond du Lac, WI 54935
920-926-9800
excelengineer.com

COLLABORATION

BriMark Builders, LLC

PROJECT INFORMATION

NEW HOTEL FOR:
COBBLESTONE HOTEL AND SUITES
WISCONSIN AVE & N GRAND AVE. • WAUKESHA, WI

PROFESSIONAL SEAL

PRELIMINARY DATES
OCT. 10, 2023
NOV. 1, 2023

NOT FOR CONSTRUCTION

JOB NUMBER
2269000

SHEET NUMBER
C1.3

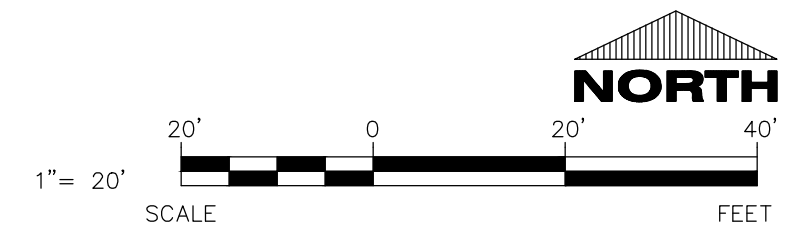

CIVIL UTILITY PLAN

SPECIFICATION NOTE:
SEE SHEET C0.1 FOR PLAN
SPECIFICATIONS AND REQUIREMENTS

NOTE:
FOR MASS PLANTINGS
EXCAVATE ENTIRE
BED & BACKFILL
W/ PREPARED SOIL.

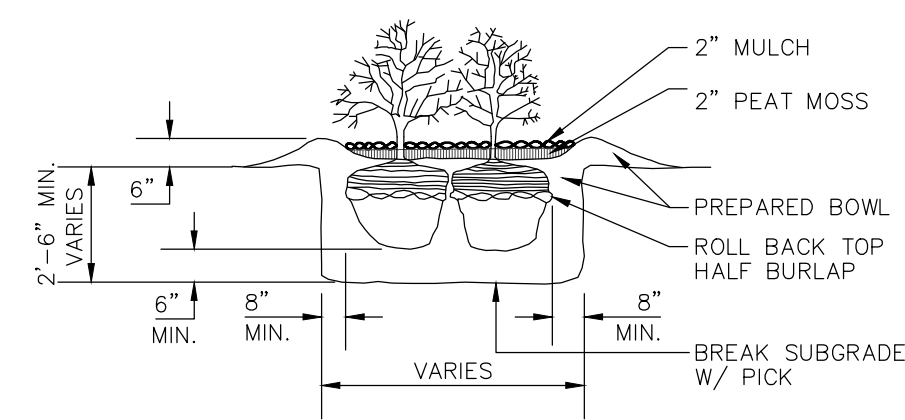

SHRUB PLANTING DETAIL
NO SCALE

Symbol	Name	Size	Quantity	Comments
TREE				
○	TBD (MULTIPLE SPECIES)	TBD	4	1
SHRUB				
⊗	JUNIPERS	1 GAL CONTAINER	17	
⊗	HEDGE COTTONEASTER	1 GAL CONTAINER	45	
PERENNIAL				
⊗	DAYLILY	1 GAL CONTAINER	27	
⊗	KARL FOERSTER REED GRASS	1 GAL CONTAINER	5	
3-4" RIVER ROCK PLANTER BEDS W/LANDSCAPE FABRIC				



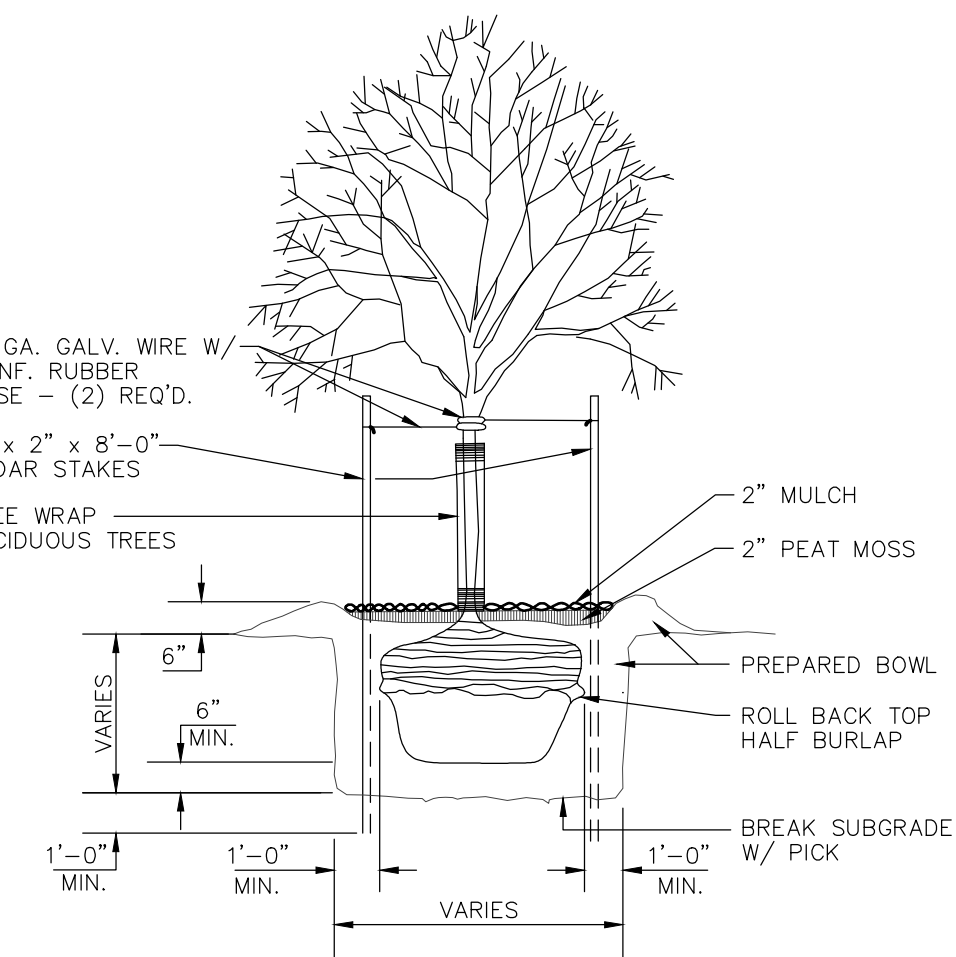

NOTES:
1. CONTRACTOR TO PROPOSE OPTIONS AND GET OWNER APPROVAL FOR THIS TREE

GRASS SEEDING TO INCLUDE ENTIRE PROPERTY TO LOT BOUNDARY. PROVIDE ALTERNATE PRICING FOR SOD PLACEMENT INSTEAD OF SEEDING.

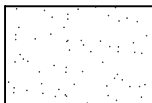

TREE PLANTING DETAIL
NO SCALE

LANDSCAPE/PAVEMENT HATCH KEY

-  BUILDING
-  SIDEWALK / CONCRETE
-  ASPHALT
-  ROCK MULCH
-  LAWN

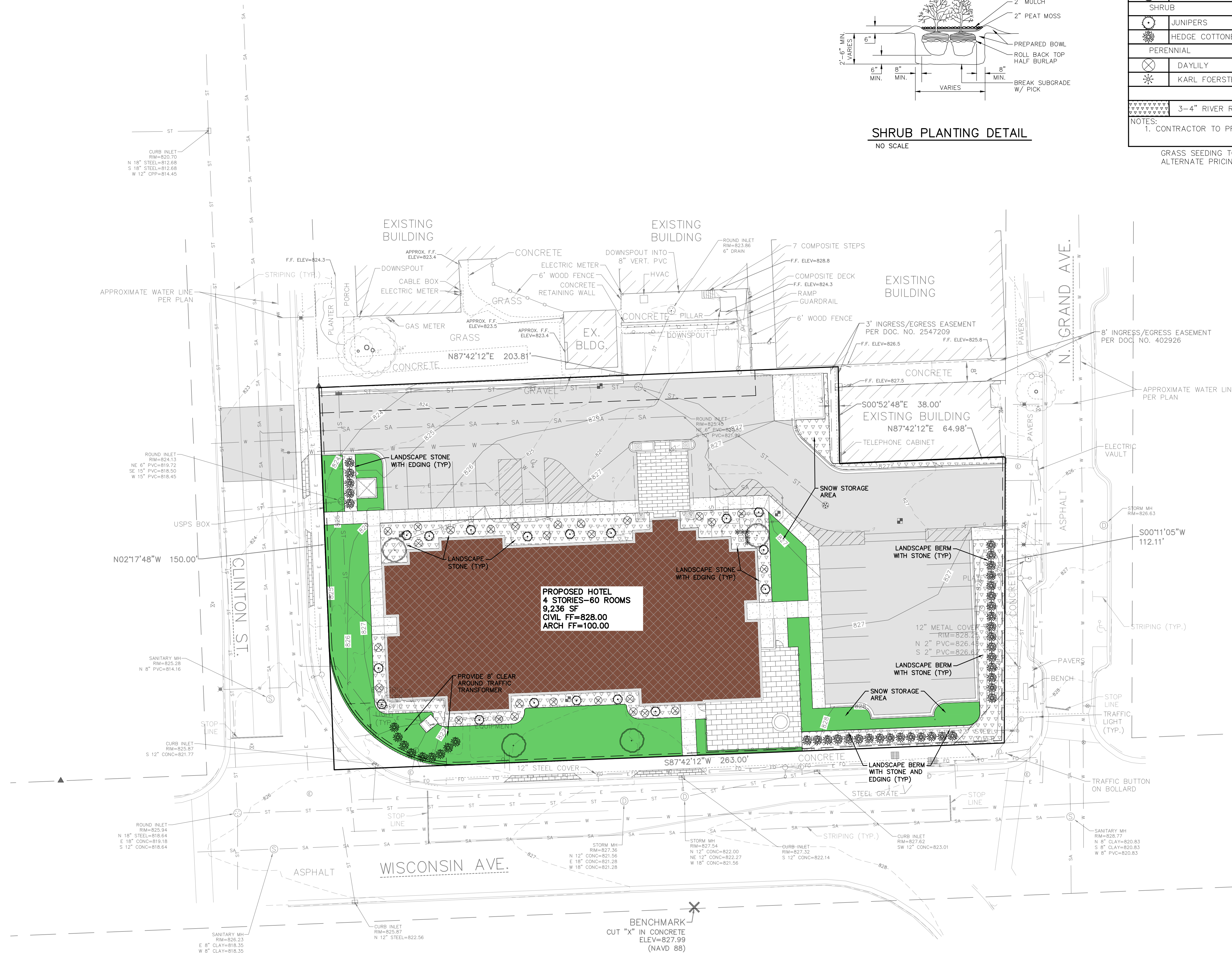

PROJECT INFORMATION

NEW HOTEL FOR:
COBBLESTONE HOTEL AND SUITES
WISCONSIN AVE & N GRAND AVE. • WAUKESHA, WI

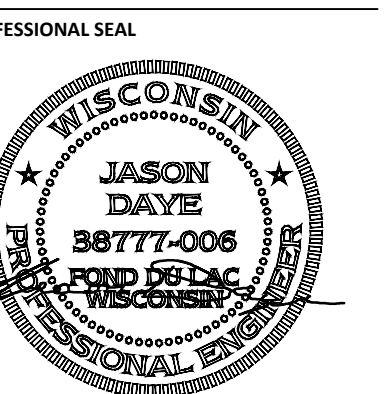

PRELIMINARY DATES
OCT. 10, 2023
NOV. 1, 2023

NOT FOR CONSTRUCTION

JOB NUMBER
2269000

SHEET NUMBER
C1.4

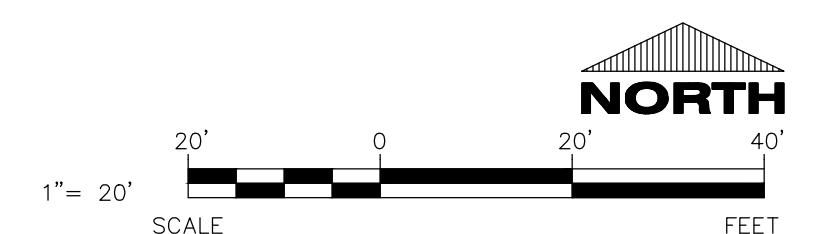

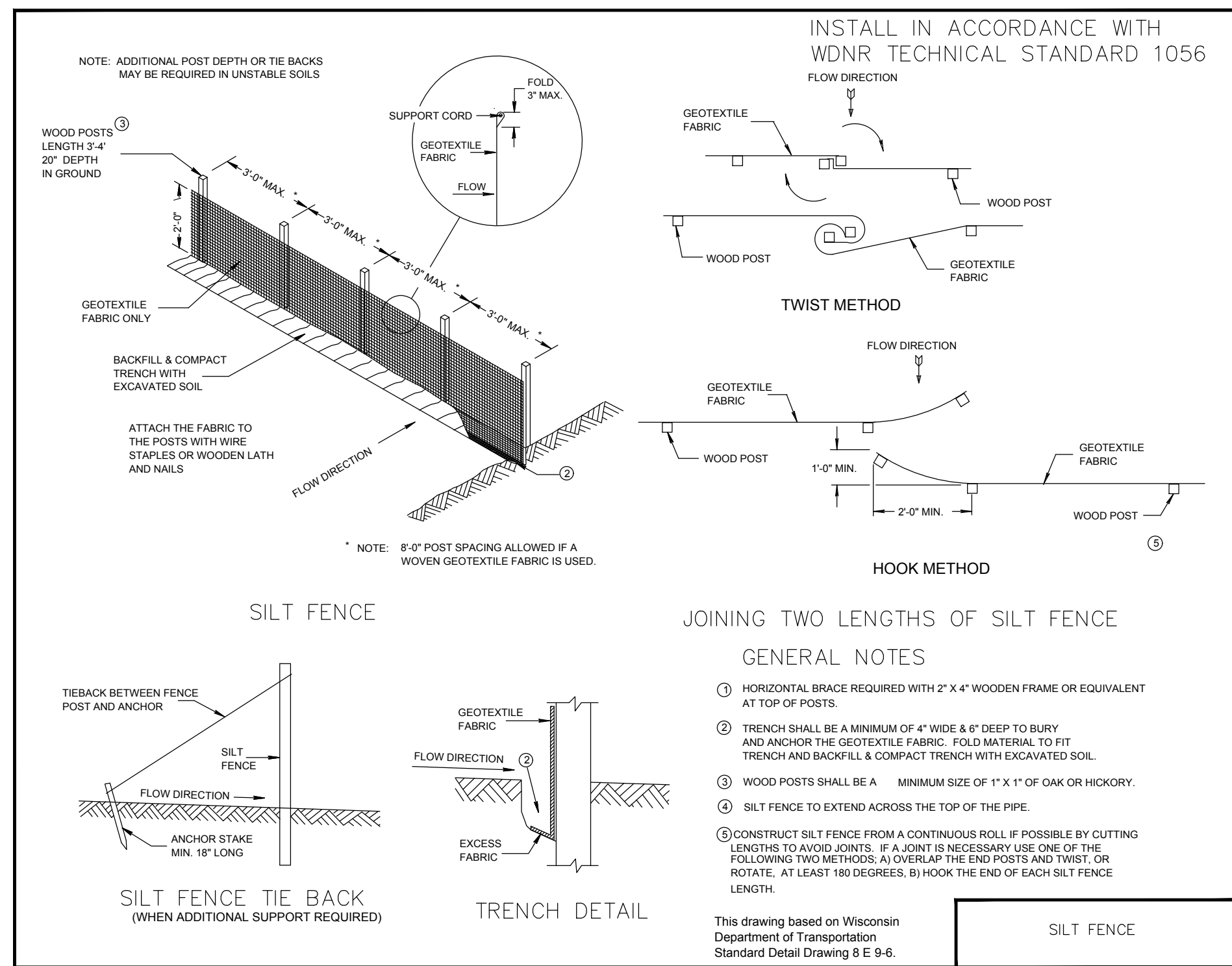

SILT FENCE - INSTALLATION DETAIL
NO SCALE

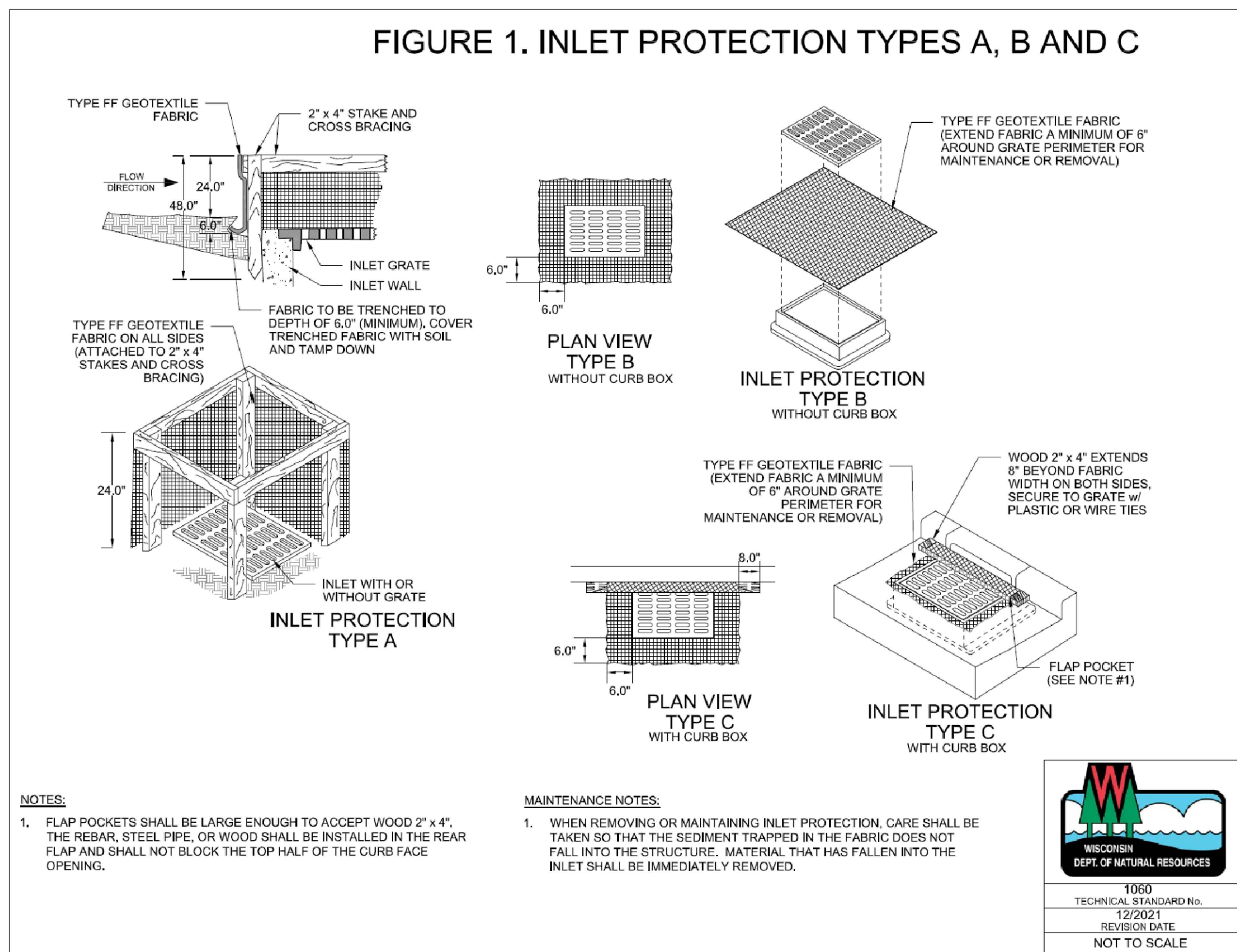

INLET PROTECTION DETAIL
NO SCALE

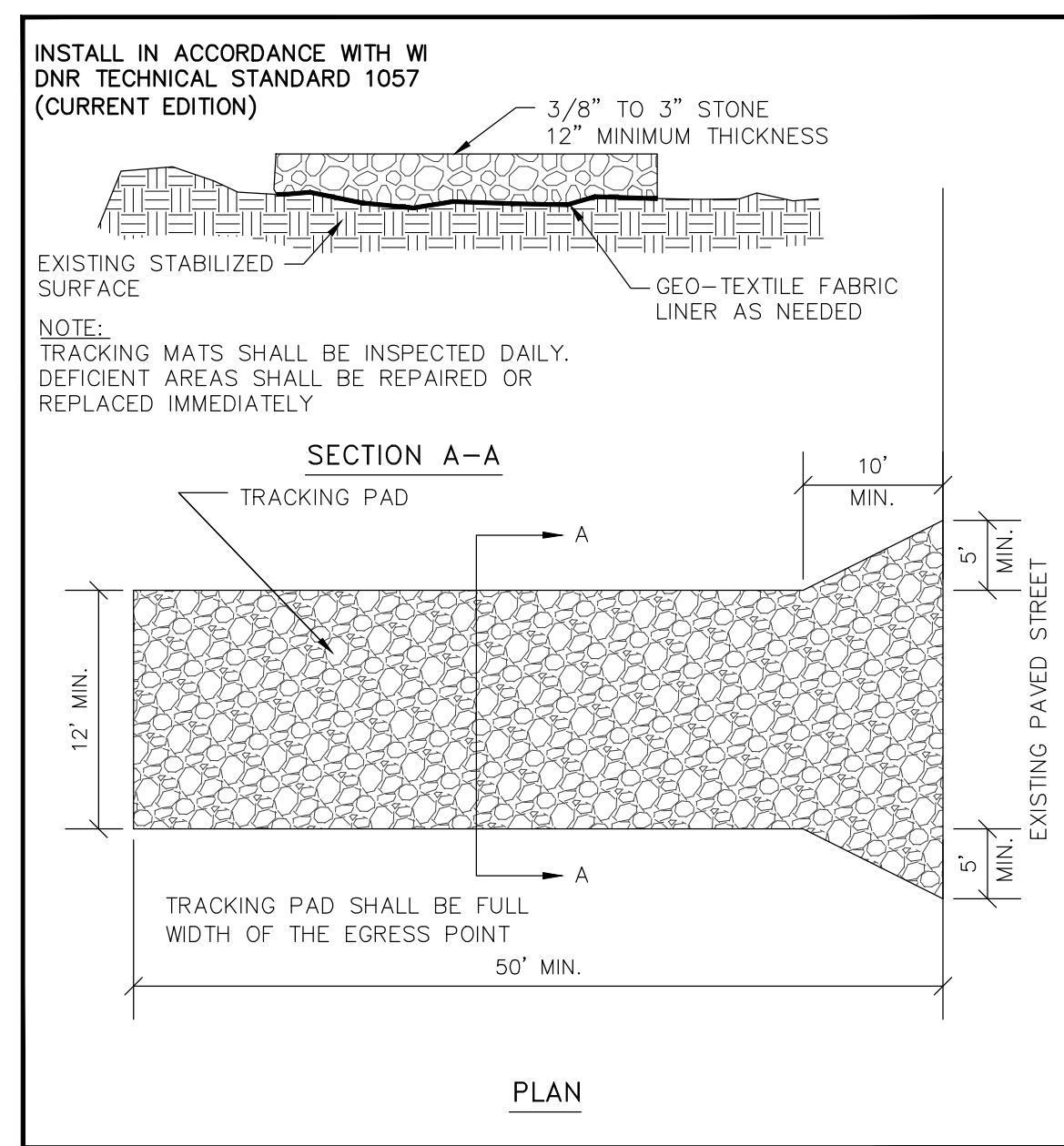
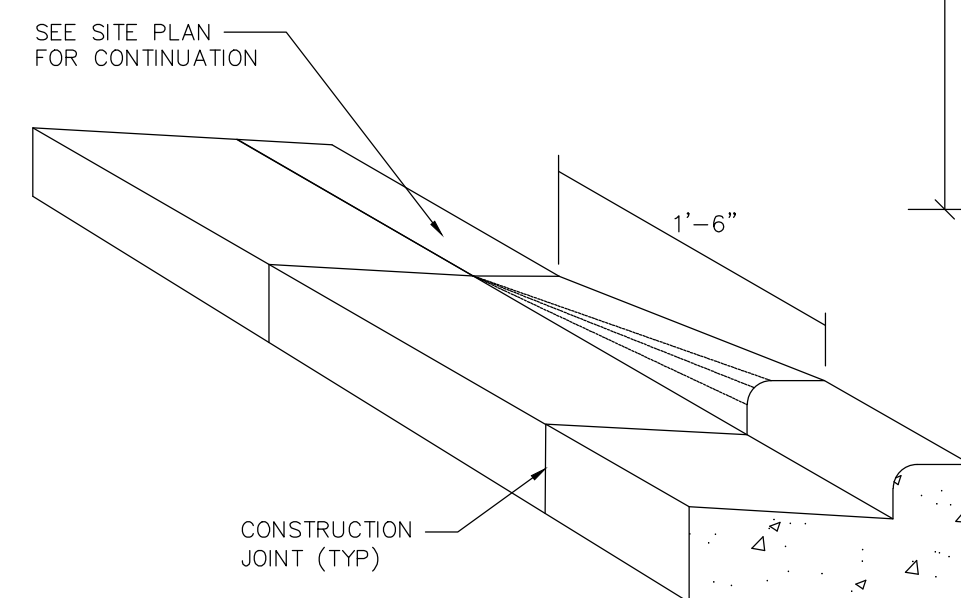

TRACKPAD DETAILS
NO SCALE

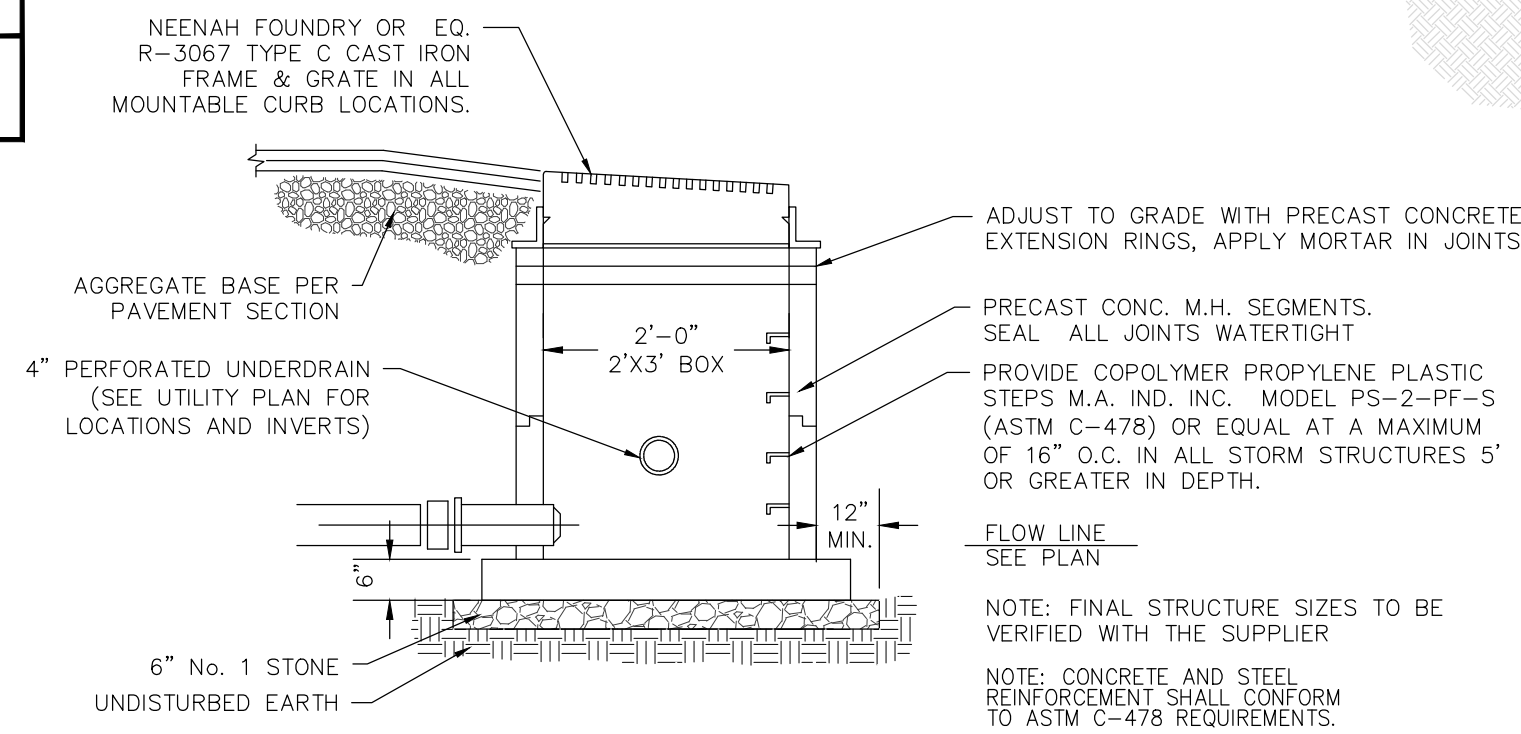

STORM MOUNTABLE CURB INLET DETAIL
NO SCALE

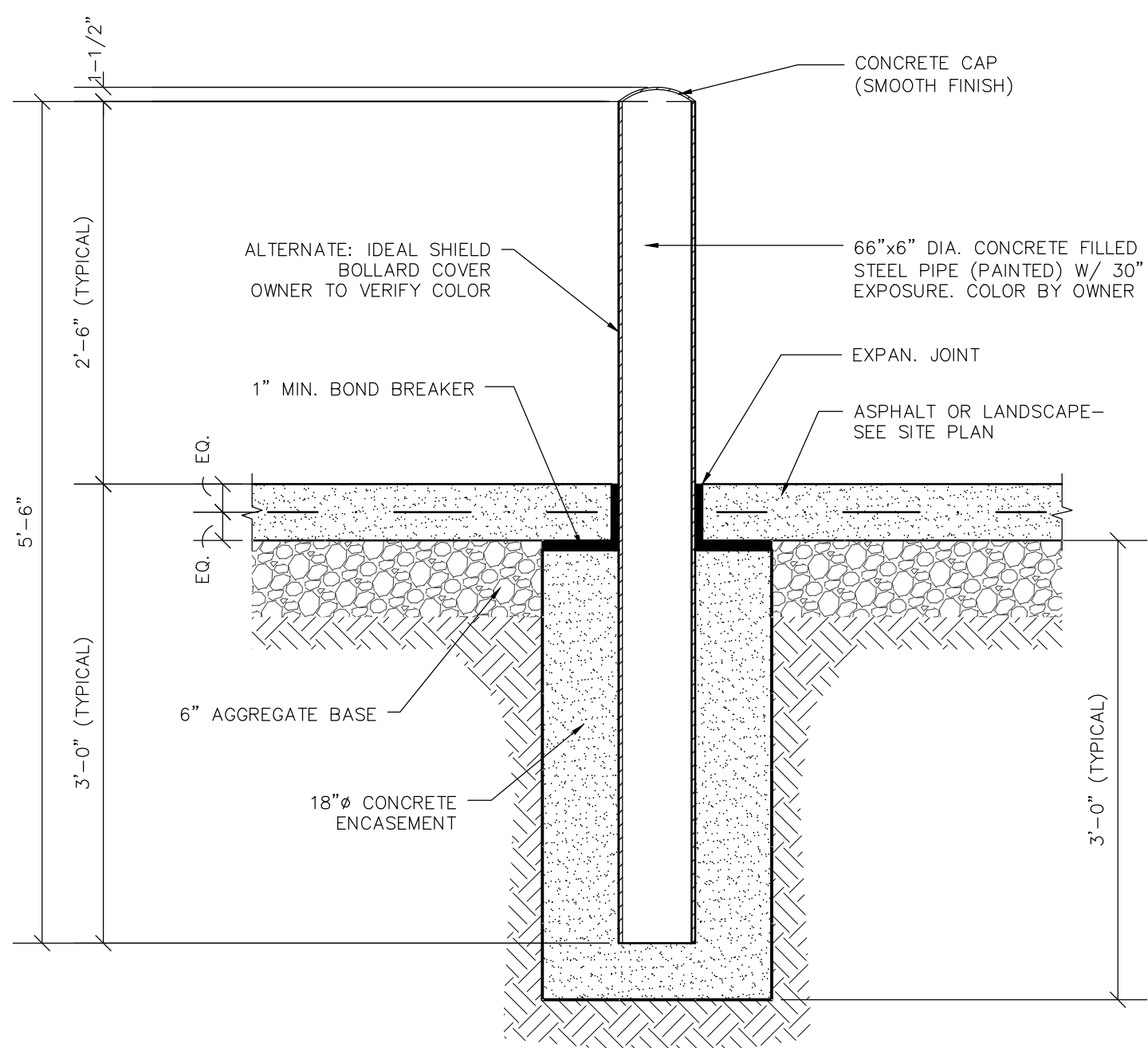

6" PIPE BOLLARD DETAIL
NO SCALE

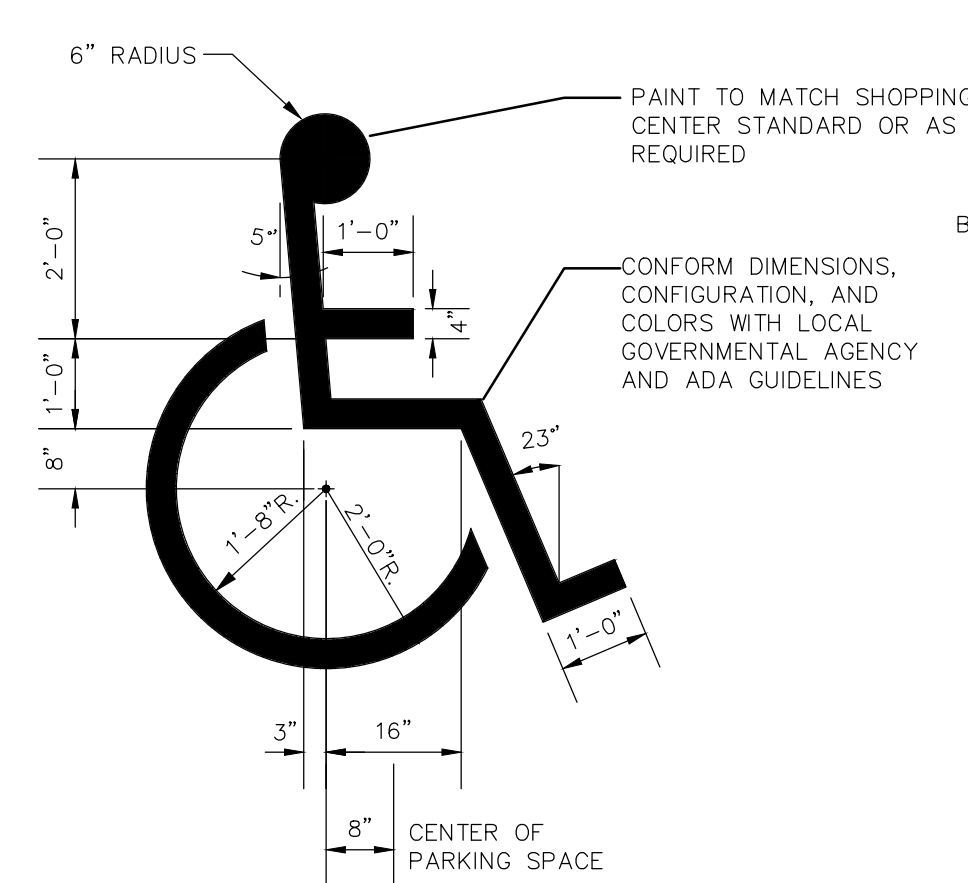

HANDICAP STALL SYMBOL
NO SCALE

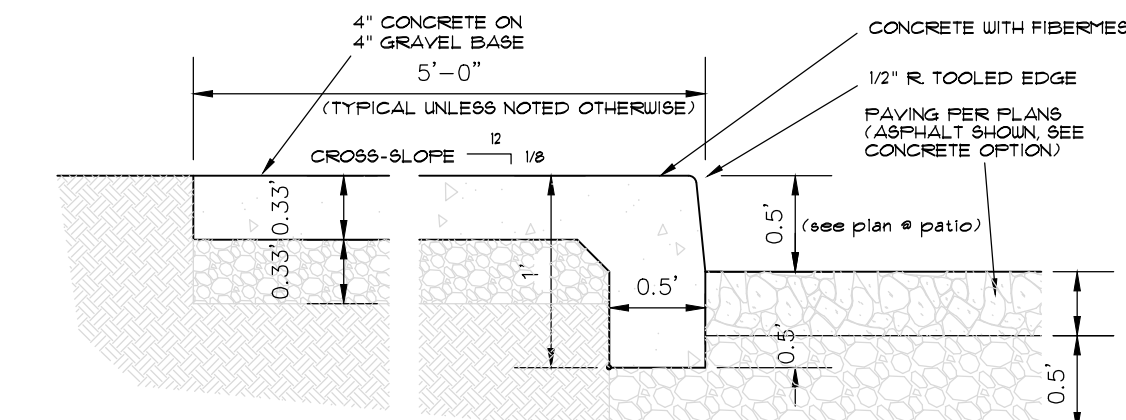

PAVING BELOW CANOPY
NOT TO SCALE

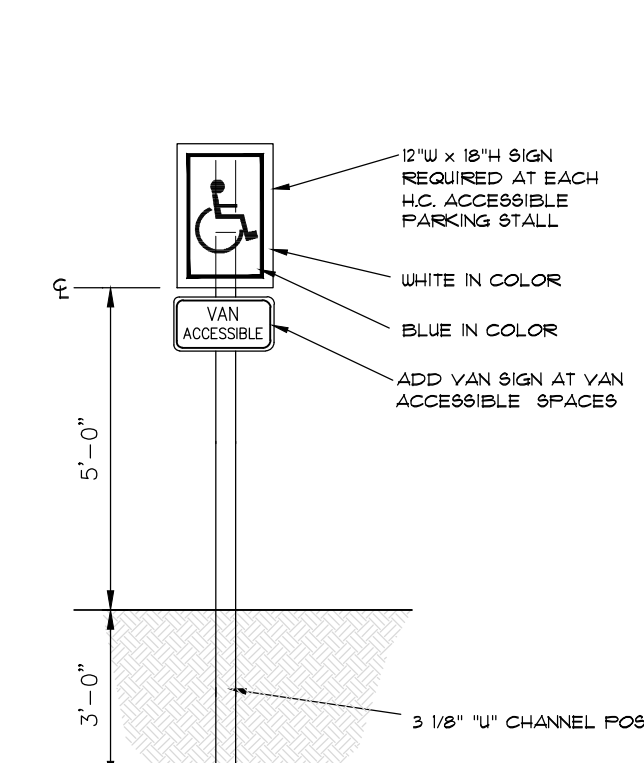

HANDICAP SIGN
NOT TO SCALE

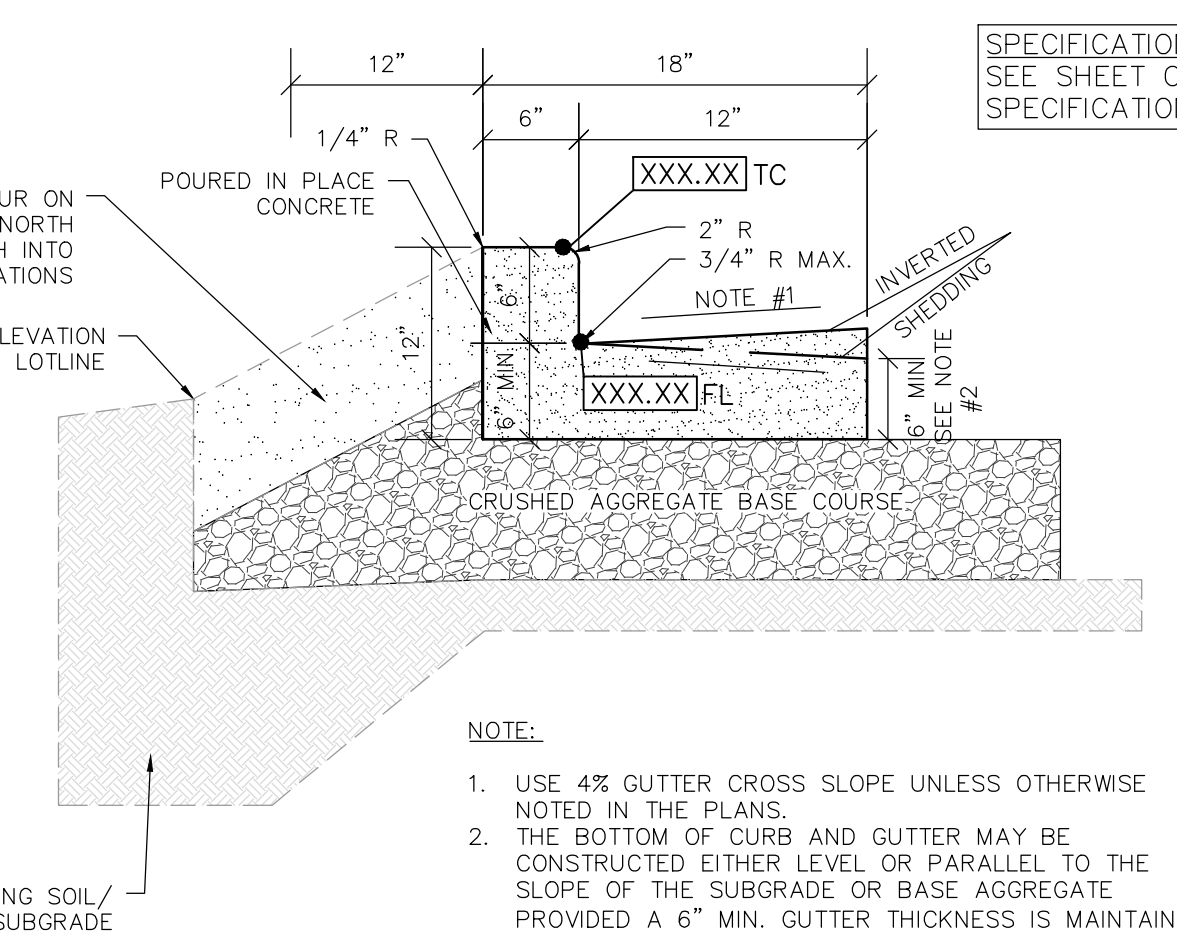

18" CONCRETE CURB & GUTTER DETAIL
NO SCALE

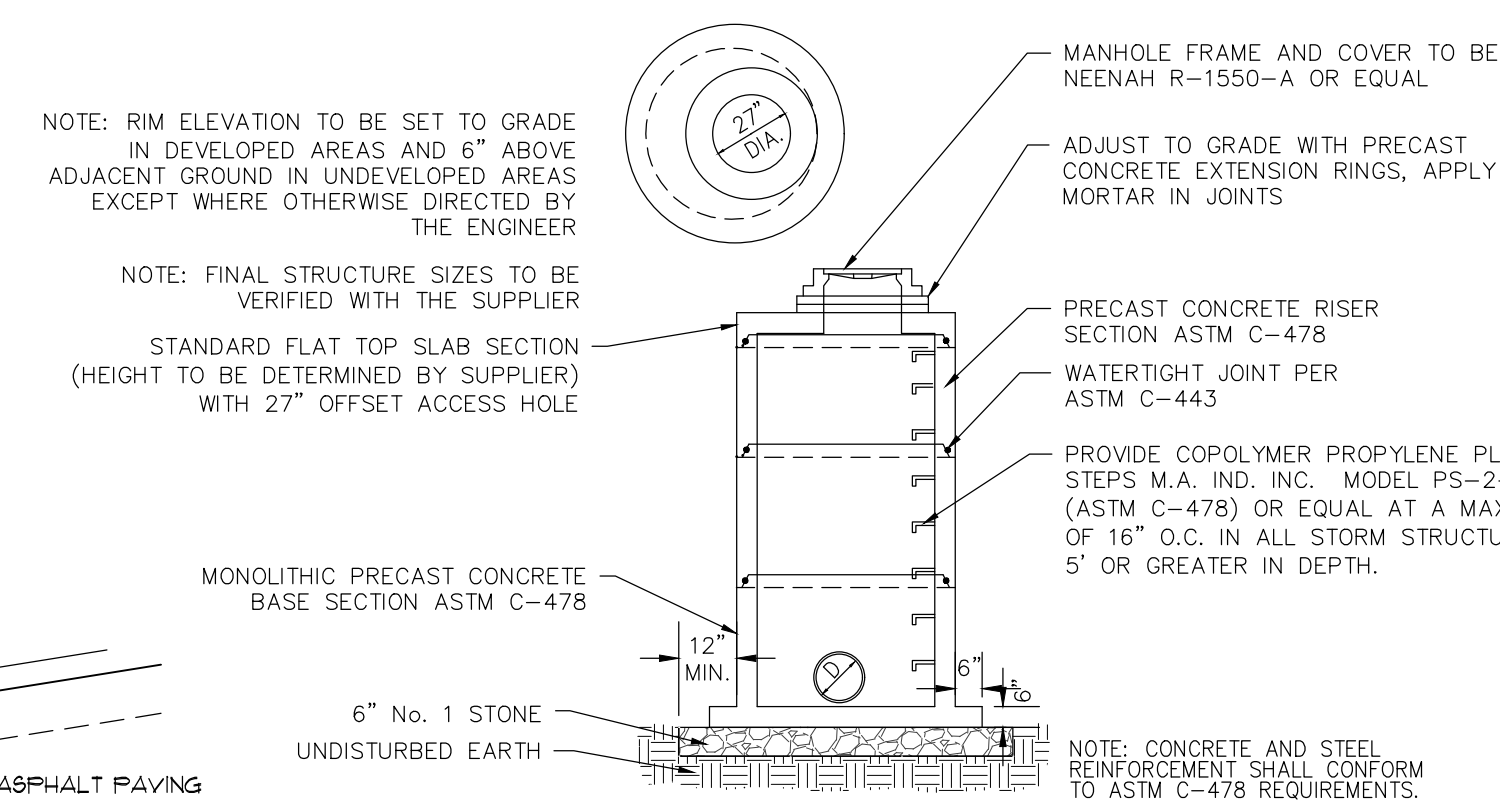

STORM MANHOLE DETAIL
NO SCALE

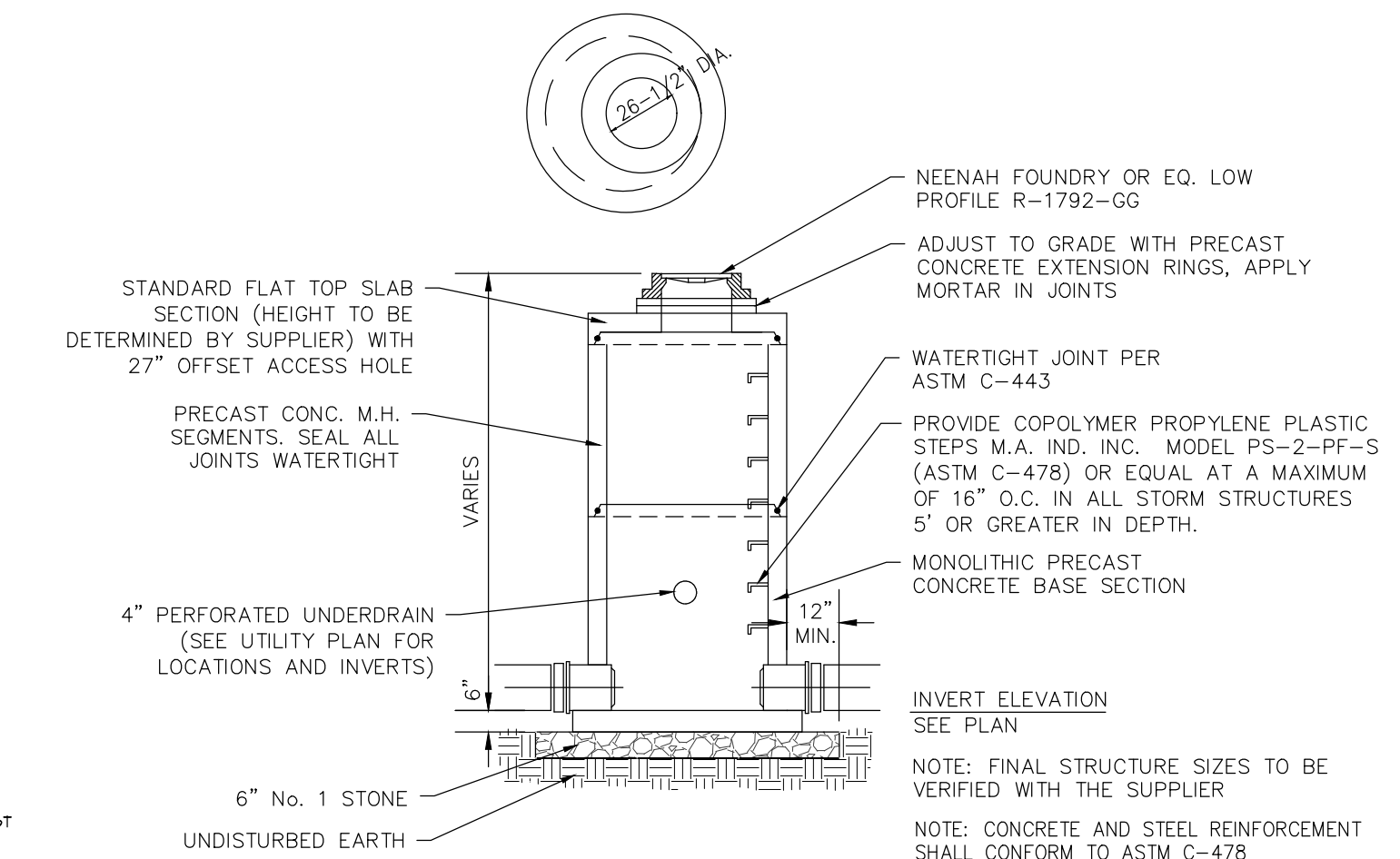

STORM CATCH BASIN DETAIL
NO SCALE

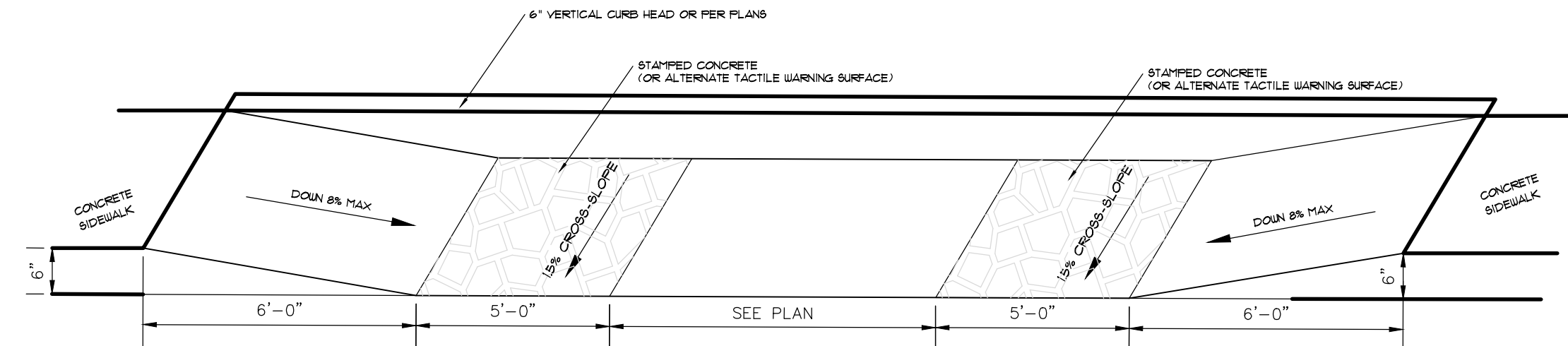

ACCESSIBLE SIDEWALK ACCESS
NOT TO SCALE



Always a Better Plan

100 Camelot Drive
Fond du Lac, WI 54935
920-926-9800
excelengineer.com



PROJECT INFORMATION

NEW HOTEL FOR:
COBBLESTONE HOTEL AND SUITES
WISCONSIN AVE & N GRAND AVE. • WAUKESHA, WI

PROFESSIONAL SEAL

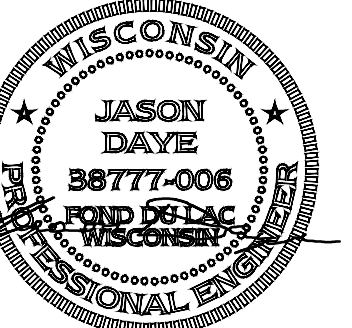

PRELIMINARY DATES

OCT. 10, 2023
NOV. 1, 2023

NOT FOR CONSTRUCTION

JOB NUMBER

2269000

SHEET NUMBER

C2.0

CIVIL DETAILS



Always a Better Plan

100 Camelot Drive
Fond du Lac, WI 54935
920-926-9800
excelengineer.com

COLLABORATION



PROJECT INFORMATION

NEW HOTEL FOR:
COBBLESTONE HOTEL AND SUITES
WISCONSIN AVE & N GRAND AVE. • WAUKESHA, WI

PROFESSIONAL SEAL

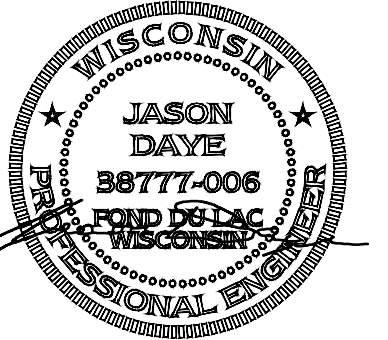

PRELIMINARY DATES

OCT. 10, 2023

NOT FOR CONSTRUCTION

JOB NUMBER

2269000

SHEET NUMBER

C3.1

2023 © EXCEL ENGINEERING, INC.

Schedule	Item	Quantity	Unit	Description	Notes	Start Date	End Date	Days
L43	1	1	DAY	CONCRETE WORK	CONCRETE WORK FOR FOUNDATION AND SLAB	10/10/23	10/10/23	1
L14	1	1	DAY	CONCRETE WORK	CONCRETE WORK FOR FOUNDATION AND SLAB	10/10/23	10/10/23	1

Statistics

Description	Symbol	Avg	Max	Min	Max/Min	Avg/Min
Overall Site	+	0.2 ft	1.4 ft	0.0 ft	N/A	N/A
Parking	X	0.6 ft	1.4 ft	0.1 ft	14.0:1	6.0:1

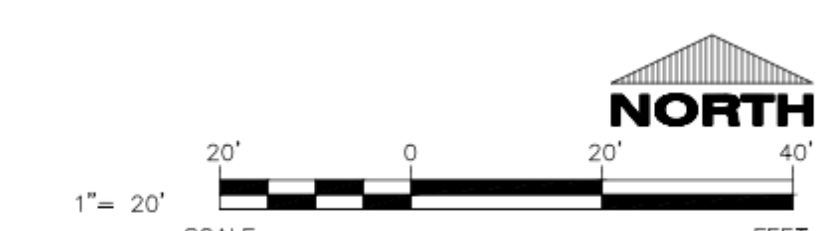
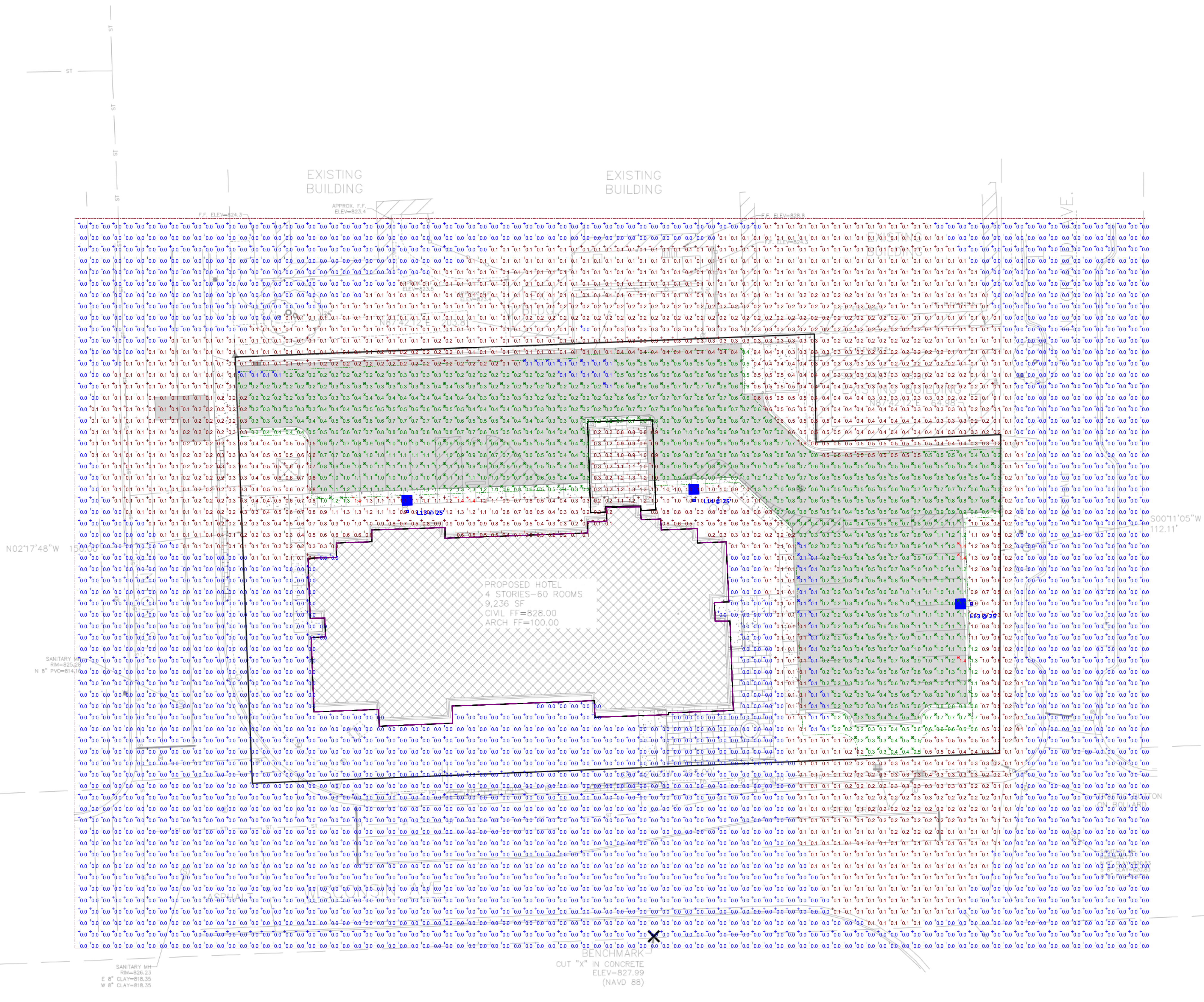

CIVIL SITE PHOTOMETRIC PLAN & DETAILS

