

**1 FLOOR PLAN**  
A-1.1 SCALE: 3/16" = 1' - 0"  
4,727 SQ. FT. NORTH

**GENERAL NOTES:**

- CONSTRUCTION TYPE 5B, UNSPRINKLERED
- ELECTRICAL, HVAC, PLUMBING AND CONTRACTORS TO PROVIDE COMPLETE SYSTEMS WITH ALL NECESSARY PLAN REVIEW AND PERMITS.
- EXIT SIGNS SHALL BE ILLUMINATED AT ALL TIMES. ENSURE CONTINUED ILLUMINATION FOR A DURATION OF NOT LESS THAN 90 MINUTES IN CASE OF PRIMARY POWER LOSS. EXIT SIGNS SHALL BE CONNECTED TO AN EMERGENCY ELECTRICAL SYSTEM PROVIDED FROM STORAGE BATTERIES.
- PROVIDE AN EMERGENCY ILLUMINATION POWER ALONG EGRESS PATHS IN ACCORDANCE W/ ICC ELECTRICAL CODE. ILLUMINATION IS TO LAST FOR A DURATION OF NOT LESS THAN 90 MINUTES AND SHALL CONSIST OF STORAGE BATTERIES (INTERIOR & EXTERIOR)
- ELECTRIC CONTRACTOR TO PROVIDE SUFFICIENT TEMPORARY POWER AND LIGHTING DURING CONSTRUCTION
- TENANT SPACE IS TO HAVE AN ACCESSIBLE WATER BOTTLE DRINKING FOUNTAIN WITH INDIVIDUAL DRINKING CUPS FURNISHED BY TENANT (NO PLUMBING) ELECTRICIAN TO PROVIDE OUTLET FOR COOLER
- ALL PERIMETER WINDOW SILLS ARE TO BE PLASTIC LAMINATE WITH DRYWALL RETURNS. (COLOR BY ARCHITECT)
- ALL WALLS TO RECEIVE PRIMER WITH EGGSHELL TEXTURE BY DRYWALL CONTRACTOR AND (2) COATS OF LATEX PAINT BY PAINTING CONTRACTOR
- ALL GLAZING WITHIN A 2'-0" ARC OF EITHER VERTICAL EDGE OF THE DOOR IN A CLOSED POSITION AND WHERE THE BOTTOM EXPOSED EDGE OF THE GLAZING IS LESS THAN 2'-0" ABOVE THE WALKING SURFACE ARE TO BE TEMPERED SAFETY GLASS (TYPICAL)
- FURNISH AND INSTALL DOORS AND WINDOW ASSEMBLIES AS INDICATED ON THE PLANS ALONG WITH ALL HARDWARE INDICATED AND THAT MAY BE REQUIRED FOR A COMPLETE JOB. ALL DOORS AND WINDOWS SHALL OPERATE SMOOTHLY WITHOUT BIND AND BE INSTALLED PLUMB AND TRUE. ALL HARDWARE SHALL FIT PROPERLY AND BE ADJUSTED AS REQUIRED. ALL FRAMES SHALL MEET OR EXCEED AAMA 6013 AND A511 183. SEE SCHEDULES FOR MORE INFORMATION.
- ALL LOCKSETS SHALL BE LEVER TYPE AS REQUIRED TO MEET REQUIREMENTS OF THE ADA. ALL OTHER HARDWARE SHALL CONFORM TO THE REQUIREMENTS OF ADA. ALL EXIT DOORS SHALL BE EQUIPPED WITH LEVER TYPE EXIT HARDWARE OPERABLE FROM THE INSIDE WITHOUT THE USE OF A LATCH, KEY OR BOLT. SCHLAGE "A" SERIES OR APPROVED EQUAL.
- DRYWALL CONTRACTOR TO INSTALL DRYWALL PER THE LATEST EDITIONS OF "RECOMMENDED SPECIFICATIONS FOR THE APPLICATION AND FINISHING OF GYPSUM BOARD" G4-16 AS PUBLISHED BY THE GYPSUM ASSOCIATION AND THE "GYPSUM CONSTRUCTION HANDBOOK" AS PUBLISHED BY UNITED STATES GYPSUM COMPANY. NOTE: PROVIDE CONTROL JOINTS PER THESE REQUIREMENTS. PROVIDE VNTL EDGE TRIM @ EXTERIOR DRYWALL CEILING IF REQUIRED.
- TOILET ROOMS TO MEET ADA REGULATIONS AND TO HAVE STANDARD ACCESSORIES AND DISPENSERS.
- ALL EXHAUST FAN VENTING THROUGH ROOF BY HVAC CONTRACTOR. COORDINATE INSTALLATION WITH JOB SUPERINTENDENT.
- ALL ROOF TOP PENETRATIONS ARE TO BE PREFINISHED METAL OR PAINTED TO MATCH THE ROOF. VERIFY COLOR WITH ARCHITECT PRIOR TO INSTALLATION. COORDINATE INSTALLATION WITH JOB SUPERINTENDENT.
- ALL SIGNAGE SHALL MEET THE REQUIREMENTS OF THE ADA.
- WHERE PERMANENT IDENTIFICATION IS PROVIDED FOR ROOMS AND SPACES, SIGNS SHALL BE INSTALLED ON THE WALL ADJACENT TO LATCH SIDE OF THE DOOR WHERE THERE IS NO WALL SPACE TO THE LATCH SIDE OF THE DOOR, INCLUDING AT THE DOUBLE LEAF DOORS, SIGNS SHALL BE PLACED ON THE NEAREST ADJACENT WALL. SUBMIT TEXT FOR APPROVAL PRIOR TO FABRICATION.
- MOUNTING HEIGHT SHALL BE 60" ABOVE FINISH FLOOR TO THE CENTERLINE OF THE SIGN UNLESS OTHERWISE NOTED.
- GENERAL CONTRACTOR TO FURNISH AND INSTALL EXTINGUISHERS PER I.B.C. SECTION 906 AND NFPA 1018-1019 MOUNT FIRE EXTINGUISHER NOT HIGHER THAN 48" ABOVE FINISH FLOOR UNLESS LOCAL REGULATIONS REQUIRED DIFFERENT HEIGHT. ALL FIRE EXTINGUISHERS AND CABINETS TO MEET THE REQUIREMENTS OF THE ADA.
- MASON TO USE COLORED MORTAR TO MATCH ADJACENT BLOCK COLOR. VERIFY COLOR WITH ARCHITECT PRIOR TO INSTALLATION.
- MASON IS TO USE DUR-O-WAL TRIANGLE TIE MODEL # D/A 101 AND DUR-O-WAL MODEL # D/A 210 ANCHOR SCREW TO STUDS WITH (2) SCREWS, TRIANGLES AND ANCHORS ARE TO BE HOT DIPPED FINISH MASON IS TO UTILIZE (1) TIE ASSEMBLY FOR EVERY 228 SQ FT OR WALL AREA (MAXIMUM).

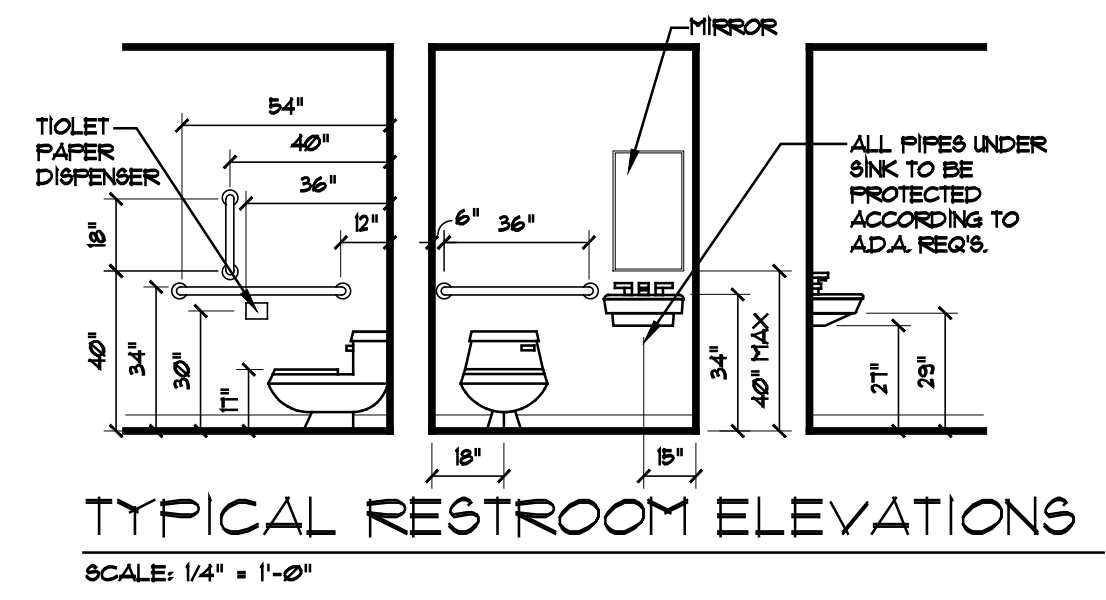

**TYPICAL RESTROOM ELEVATIONS**  
SCALE: 1/4" = 1'-0"

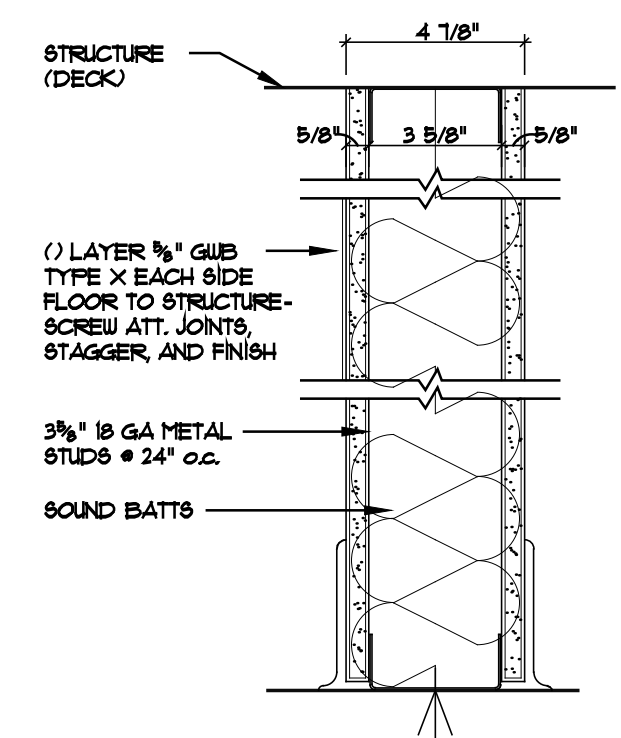

**P1 TYPICAL DEMISING WALL**

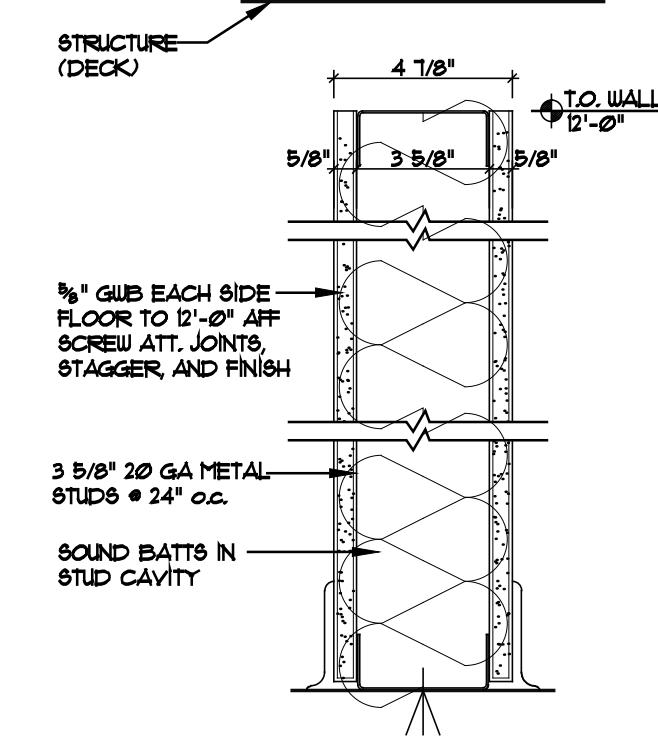

**P2 TYPICAL INTERIOR WALL**