

Storm Water Management Practice Maintenance Agreement

Kwik Trip, Inc., as “Owner” of the property described below, in accordance with Chapter 32 City of Waukesha Storm Water Management and Erosion Control, agrees to install and maintain storm water management practice(s) on the subject property in accordance with approved plans and Storm Water Management Plan conditions. The owner further agrees to the terms stated in this document to ensure that the storm water management practice(s) continues serving the intended functions in perpetuity. This Agreement includes the following exhibits:

Exhibit A: Legal Description of the real estate for which this Agreement applies (“Property”).

Exhibit B: Location Map(s) – shows an accurate location of each storm water management practice affected by this Agreement.

Exhibit C: Maintenance Plan – prescribes those activities that must be carried out to maintain compliance with this Agreement.

Note: After construction verification has been accepted by the City of Waukesha, for all planned storm water management practices, an addendum(s) to this agreement shall be recorded by the Owner showing design and construction details. The addendum(s) may contain several additional exhibits, including certification by City of Waukesha of Storm Water and Erosion Control Permit termination, as described below.

Name and Return Address

City of Waukesha
130 Delafield Street
Waukesha, WI 53188

Parcel Identification Number(s)

WAKC0997074 & WAKC0997075

Through this Agreement, the Owner hereby subjects the Property to the following covenants, conditions and restrictions:

1. The Owner shall be responsible for the routine and extraordinary maintenance and repair of the storm water management practice(s) and drainage easements identified in Exhibit B until Storm Water and Erosion Control Permit termination by the City of Waukesha in accordance with Chapter 32 of the City Code of Ordinances.
2. After Storm Water and Erosion Control Permit termination under 1., the current Owner(s) shall be solely responsible for maintenance and repair of the storm water management practices and drainage easements in accordance with the maintenance plan contained in Exhibit C.
3. The Owner(s) shall, at their own cost, complete inspections of the storm water management practices at the time intervals listed in Exhibit C, and conduct the inspections by a qualified professional, file the reports with the City of Waukesha after each inspection and complete any maintenance or repair work recommended in the report. The Owner(s) shall be liable for the failure to undertake any maintenance or repairs. After the work is completed by the Contractor, the qualified professional shall verify that the work was properly completed and submit the follow-up report to the City within 30 days.
4. In addition, and independent of the requirements under paragraph 3 above, the City of Waukesha, or its designee, is authorized to access the property as necessary to conduct inspections of the storm water management practices or drainage easements to ascertain compliance with the intent of this Agreement and the activities prescribed in Exhibit C. The City of Waukesha may require work to be done which differs from the report described in paragraph 3 above, if the City of Waukesha reasonably concludes that such work is necessary and consistent with the intent of this agreement. Upon notification by the City of Waukesha of required maintenance or repairs, the Owner(s) shall complete the specified maintenance or repairs within a reasonable time frame determined by the City of Waukesha.
5. If the Owner(s) do not complete an inspection under 3. above or required maintenance or repairs under 4. above within the specified time period, the City of Waukesha is authorized, but not required, to perform the specified inspections, maintenance or repairs. In the case of an emergency situation, as determined by the City of Waukesha, no notice shall be required prior to the City of Waukesha performing emergency maintenance or repairs. The City of Waukesha may levy the costs and expenses of such inspections, maintenance or repair related actions as a special charge against the Property and collected as such in accordance with the procedures under s. 66.0627 Wis. Stats. or subch. VII of ch. 66 Wis. Stats.

6. This Agreement shall run with the Property and be binding upon all heirs, successors and assigns. After the Owner records the addendum noted above, the City of Waukesha shall have the sole authority to modify this agreement upon a 30-day notice to the current Owner(s).

Dated this ___ day of _____, 201_.

Owner:

(Owners Signature)

(Owners Typed Name)

Acknowledgements

State of Wisconsin:
County of Waukesha

Personally came before me this ___ day of _____, 201_, the above named ___ [Owners name]_____ to me known to be the person who executed the foregoing instrument and acknowledged the same.

[Name]
Notary Public, Waukesha County, WI
My commission expires:_____.

This document was drafted by:

Christopher White, P.E

**R.A. Smith, Inc
16745 W Bluemound Road
Brookfield, WI**

For Certification Stamp

City of Waukesha Common Council Approval

Dated this ___ day of _____, 201_.

Shawn N. Reilly, Mayor

Gina Kozlik, City Clerk

Acknowledgements

State of Wisconsin:
County of Waukesha

Personally came before me this ___ day of _____, 201_, the above named _____ to me known to be the person who executed the foregoing instrument and acknowledged the same.

[Name]
Notary Public, Waukesha County, WI
My commission expires: _____.

Exhibit A – Legal Description

The following description and reduced copy map identifies the land parcel(s) affected by this Agreement. For a larger scale view of the referenced document, contact the Waukesha County Register of Deeds office.

Project Identifier: **Kwik Trip #527** Acres: **1.34**

Date of Recording:

Map Produced By: **R.A. Smith, Inc**

Legal Description: **A division of Parcel 1 and part of Parcel 2 in Certified Survey Map No. 4080, all being a part of the Southeast 1/4 of the Northeast 1/4 of Section 34, Township 7 North, Range 19 East, in the City of Waukesha, Waukesha County, Wisconsin.**

Commencing at the Southeast corner of the Northeast 1/4 of said Section 34; thence North 00° 10' 06" West along the East line of said 1/4 Section a distance of 658.99 feet to a point; thence South 88° 56' 42" West 51.02 feet to a point in the West line of Pewaukee Road, said point also the point of beginning of lands to be described; thence South 00° 12' 04" East along said West line 261.53 feet to a point; thence South 45° 02' 33" West along said West line 9.98 feet to a point in the North line of Gascoigne Drive; thence South 89° 47' 56" West along said North line 191.93 feet to a point in the Easterly line of Peters Drive; thence North 01° 03' 18" West along said Easterly line 40.57 feet to a point; thence Northwesterly 98.98 feet along said Easterly line and an arc of a curve whose center lies to the Southwest, whose radius is 90.00 feet, and whose chord bears North 32° 33' 47" West 94.07 feet to a point in the East line of Lot 1, Block 3, in Peters Subdivision; thence North 30° 10' 20" East along said East line 52.39 feet to a point; thence North 01° 03' 18" West along said East line 100.00 feet to a point in the South line of Lot 1 of Certified Survey Map No. 5809; thence North 88° 56' 42" East along said South line 225.00 feet to the point of beginning.

Said lands contain 58,575 square feet or 1.3447 acres.

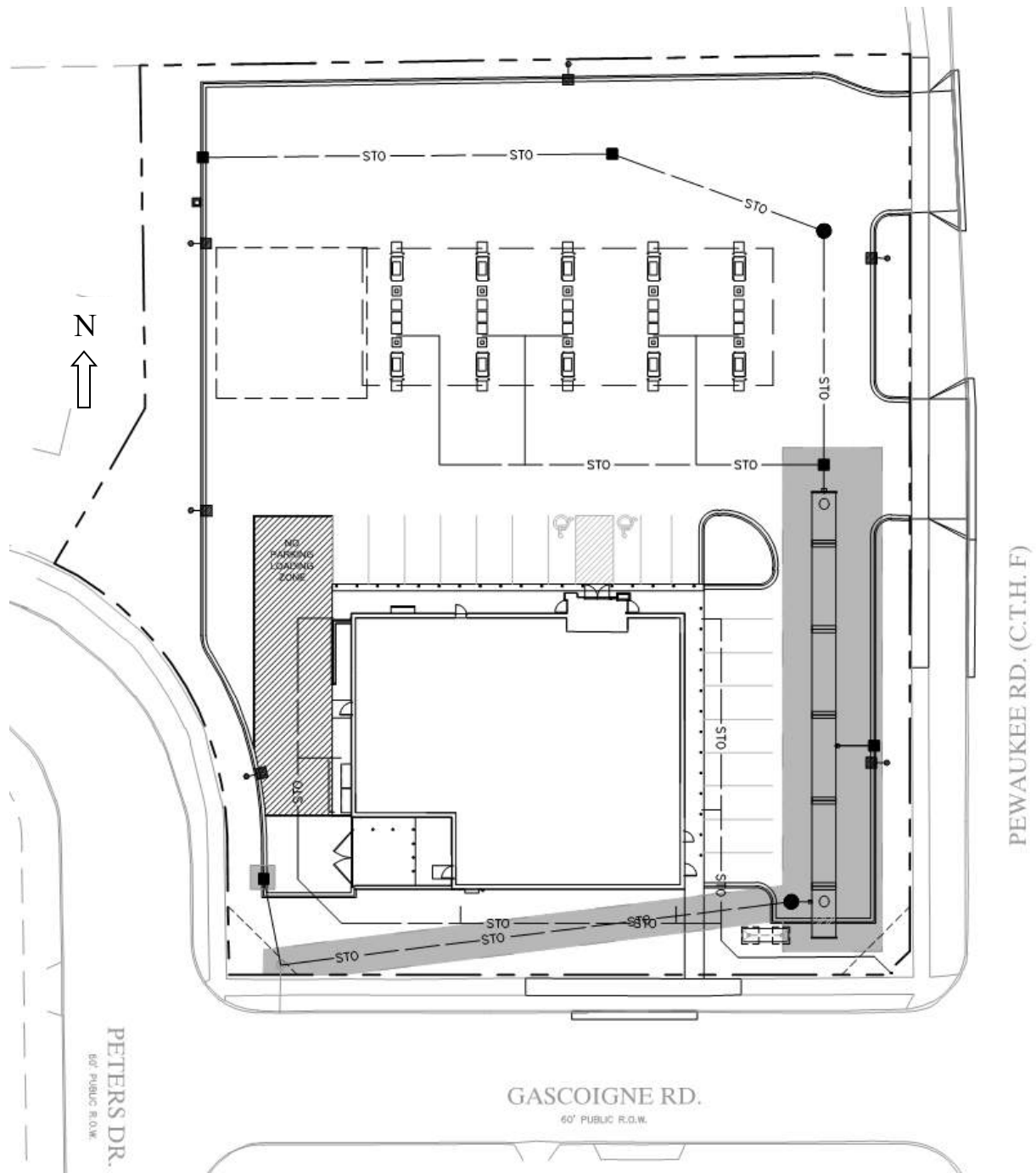

Drainage Easement Restrictions: Shaded area on map indicates a drainage easement for storm water treatment. No buildings or other structures are allowed in these areas. No grading or filling is allowed that may interrupt storm water flows in any way. See Exhibit C for specific maintenance requirements for storm water management practices within this area. See subdivision plat for details on location.

EXHIBIT

STORM WATER FACILITY EASEMENT

Easement No. 1

Part of Parcel 2 in Certified Survey Map No. 4080, all being a part of the Southeast 1/4 of the Northeast 1/4 of Section 34, Township 7 North, Range 19 East, in the City of Waukesha, Waukesha County, Wisconsin, bounded and described as follows:

Commencing at the Southeast corner of the Northeast 1/4 of said Section 34; thence North 00° 10' 06" West along the East line of said 1/4 Section a distance of 658.99 feet to a point; thence South 88° 56' 42" West 51.02 feet to a point in the West line of Pewaukee Road; thence South 00° 12' 04" East along said West line 261.53 feet to a point; thence South 45° 02' 33" West along said West line 9.98 feet to a point in the North line of Gascoigne Drive; thence South 89° 47' 56" West 181.88 feet to a point; thence North 08° 44' 36" West 25.28 feet to the point of beginning of lands to be described; thence South 89° 47' 56" West 7.00 feet to a point; thence North 00° 12' 04" West 7.00 feet to a point; thence North 89° 47' 56" East 7.00 feet to a point; thence South 00° 12' 04" East 7.00 feet to the point of beginning.

Said land contains 49 square feet.

Easement No. 2

Part of Parcels 1 and 2 in Certified Survey Map No. 4080, all being a part of the Southeast 1/4 of the Northeast 1/4 of Section 34, Township 7 North, Range 19 East, in the City of Waukesha, Waukesha County, Wisconsin, bounded and described as follows:

Commencing at the Southeast corner of the Northeast 1/4 of said Section 34; thence North 00° 10' 06" West along the East line of said 1/4 Section a distance of 658.99 feet to a point; thence South 88° 56' 42" West 51.02 feet to a point in the West line of Pewaukee Road; thence South 00° 12' 04" East along said West line 114.77 feet to a point; thence South 89° 47' 56" West 8.14 feet to the point of beginning of lands to be described; thence South 00° 12' 04" East 147.00 feet to a point; thence South 89° 47' 56" West 29.00 feet to a point; thence North 00° 12' 04" West 9.11 feet to a point; thence South 82° 46' 50" West 130.12 feet to a point in the North line of Gascoigne Drive; thence South 89° 47' 56" West along said North line 22.69 feet to a point; thence North 00° 40' 49" East 7.30 feet to a point; thence North 82° 46' 50" East 152.86 feet to a point; thence North 00° 12' 04" West 127.82 feet to a point; thence North 89° 47' 56" East 29.00 feet to the point of beginning.

Said land contains 5,761 square feet.

April 28, 2020

Drawing No. 166850-RMK

raSmith
CREATIVITY BEYOND ENGINEERING

16745 W. Bluemound Road
Brookfield, WI 53005-5938
(262) 781-1000
rasmith.com

EXHIBIT

STORM WATER FACILITY EASEMENT

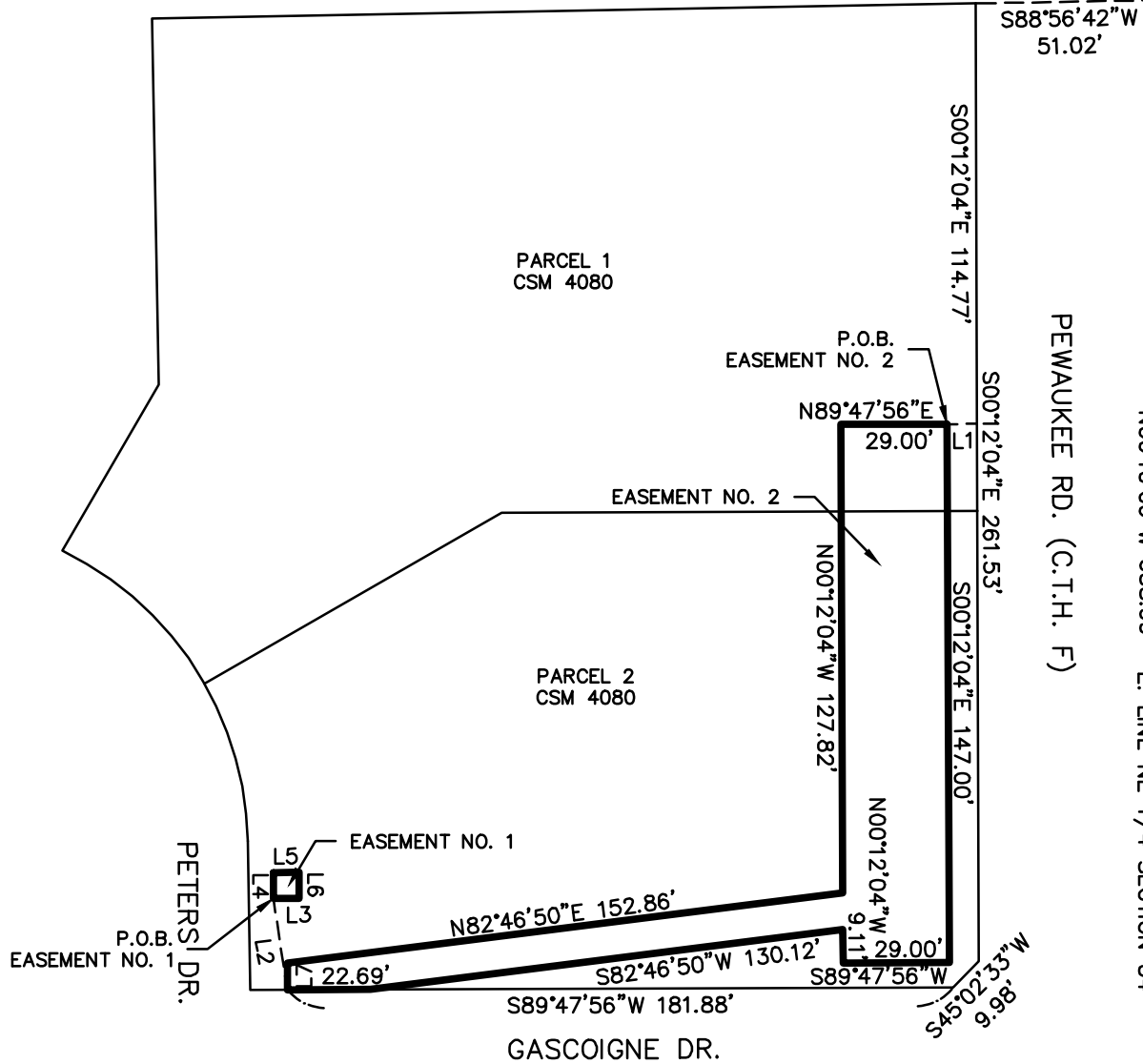

P.O.B.
EASEMENT NO. 1

P.O.B.
EASEMENT NO. 2

PEWAUKEE RD. (C.T.H. F)

PETERS DR.

GASCOIGNE DR.

N00°10'06"W 658.99' E. LINE NE 1/4 SECTION 34

SE COR OF
NE 1/4 OF
SEC. 34-7-19

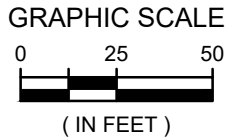

Line #	Direction	Length
L1	S89°47'56"W	8.14
L2	N08°44'36"W	25.28
L3	S89°47'56"W	7.00
L4	N00°12'04"W	7.00
L5	N89°47'56"E	7.00
L6	S00°12'04"E	7.00
L7	N00°40'49"E	7.30

raSmith
CREATIVITY BEYOND ENGINEERING

16745 W. Bluemound Road
Brookfield, WI 53005-5938
(262) 781-1000
rasmith.com

Exhibit B - Location Map

Storm Water Management Practices Covered by this Agreement

The storm water management practices covered by this Agreement are depicted in the reduced copy of a portion of the construction plans, as shown below. The practices include one underground detention tank, two snouts in storm sewer structures, and an outlet control structure. All of the noted storm water management practices are located within a drainage easement, as noted in Exhibit A.

Subdivision Name: Kwik Trip 527
Storm water Practices: Underground Detention Tank, Snouts (3), Outlet Control Structure
Location of Practices: Parcel described in Exhibit A
Owners of Parcel: Kwik Trip, Inc.

Figure 1
 Plan View of Storm Water Practices

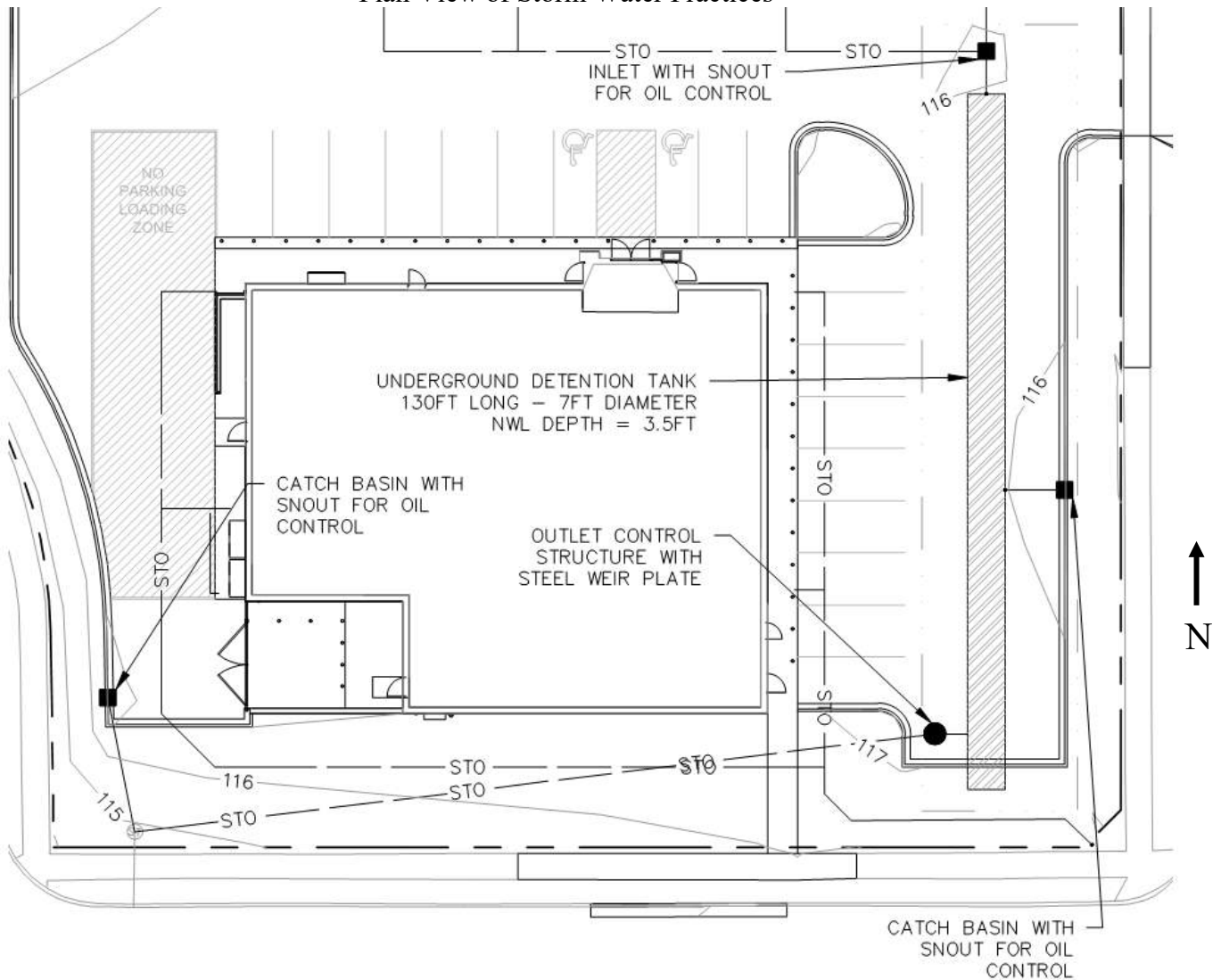

Exhibit C

Storm Water Practice Maintenance Plan

This exhibit explains the basic function of each of the storm water practices listed in Exhibit B and prescribes the minimum maintenance requirements to remain compliant with this Agreement. The maintenance activities listed below are aimed to ensure these practices continue serving their intended functions in perpetuity. The list of activities is not all inclusive, but rather indicates the minimum type of maintenance that can be expected for this particular site. Access to the stormwater practices for maintenance vehicles is shown in Exhibit B. Any failure of a storm water practice that is caused by a lack of maintenance will subject the Owner(s) to enforcement of the provisions listed on page 1 of this Agreement by the City of Waukesha.

System Description:

The underground detention tank is designed to trap 40% of sediment in runoff and maintain pre-development downstream peak flows. The underground detention tank was a 3.5ft permanent pool for settling out sediment. There are three storm sewer runs that collect runoff from around the site. The last structure in each storm sewer run has a sump and snout to control oil pollution. To ensure the storm water regulations are met the underground tank, outlet structure, and snouts must be maintained as specified in this Agreement.

The underground detention tank receives runoff from a 0.883 acre onsite drainage area and 0.09 acres offsite area. During rainfall or snow melt events, the water level will temporarily rise and slowly drain down to the elevation of the control structure. The water level is controlled by an outlet control structure with a steel plate acting as a weir. The steel weir has an 11-inch drilled hole (orifice). This orifice controls the water level and causes the pond to temporarily rise during runoff events. The three snouts in the storm sewer structures trap the oil in the runoff before the runoff flows downstream. "As-built" construction drawings of the underground tank, showing actual dimensions, elevations, outlet structures, etc. will be recorded as an addendum(s) to this agreement within 60 days after City of Waukesha accepts verification of construction from the project engineer.

Minimum Maintenance Requirements:

To ensure the proper long-term function of the storm water management practices described above, the following activities must be completed:

1. All outlet pipes must be checked monthly to ensure there is no blockage from floating debris or ice. Any blockage must be removed immediately.
2. Inlets and outlets must be checked after heavy rains (minimum of annually) for signs of erosion. Any eroding areas must be repaired immediately to prevent premature sediment build-up in the downstream forebays or basin. Erosion matting is recommended for repairing grassed areas.
3. If the permanent pool falls below 3ft, a review shall be performed to determine whether there is leakage or an insufficient water budget. If the cause is leakage, the tank shall be repaired.
4. When sediment in the tank has accumulated to over 0.5ft, it must be removed. All removed sediment must be placed in an appropriate upland disposal site and stabilized (grass cover) to prevent sediment from washing back into the basin. Failure to remove sediment will cause resuspension of previously trapped sediments and increase downstream deposition.
5. Each storm structure with the snout shall be checked for a buildup of oil semiannually. The oil and grease shall be removed and disposed of in a lawful manner.
6. Any other repair or maintenance needed to ensure the continued function of the storm water practices or as ordered by the City of Waukesha under the provisions listed on page 1 of this Agreement.
7. The titleholder(s) or their designee must document all inspections as specified above. Documentation shall include as a minimum: (a) Inspectors Name, Address and Telephone Number, (b) Date of Inspections, (c) Condition Report of the Storm Water Management Practice, (d) Corrective Actions to be Taken and Time Frame for Completion, (e) Follow-up Documentation after Completion of the Maintenance Activities. All documentation is to be delivered to the attention of the City Engineer at the City of Waukesha Engineering Department on January 10th and July 10th each year.

Addendum 1
Storm Water Management Practice
Maintenance Agreement

Document number

The purpose of this addendum is to record verified “as-built” construction details, supporting design data and permit termination documentation for the storm water management practice(s) located on Outlot 1 of the Highland Preserve Subdivision, described as being all that part of the Southwest Quarter (SW ¼) of Section 4, Township 8N, Range 19E (Town of Lisbon) Waukesha County, Wisconsin. This document shall serve as an addendum to document # _____, herein referred to as the “Maintenance Agreement”. This addendum includes all of the following exhibits:

Exhibit D: Design Summary – contains a summary of key engineering calculations and other data used to design the wet detention basin.

Exhibit E: As-built Survey – shows detailed “as-built” cross-section and plan view of the wet detention basin.

Exhibit F: Engineering/Construction Verification – provides verification from the project engineer that the design and construction of the wet detention basin complies with all applicable technical standards and Waukesha County ordinance requirements.

Exhibit G: Storm Water Management & Erosion Control Permit Termination – provides certification by the City of Waukesha that the Storm Water and Erosion Control Permit for the above noted site has been terminated.

Dated this ___ day of _____, 201_.

Owner:

[Owners Signature – per the Maintenance Agreement]

[Owners Typed Name]

Name and Return Address

WAKC0997074 & WAKC0997075

Parcel Identification Number(s) – (PIN)

Acknowledgements

State of Wisconsin County of Waukesha

Personally came before me this ___ day of _____, 201_, the above named _____ [Owners name] to me known to be the person who executed the foregoing instrument and acknowledged the same.

[Name]

Notary Public, Waukesha County, WI

My commission expires: _____.

This document was drafted by:

[Name and address of drafter]

For Certification Stamp

Exhibit D Design Summaries for the Watersheds

Project Identifier: Kwik Trip 527 **Property Size:** 1.34 Acres
Number of Runoff Discharge Points: 1 **Watershed (ultimate discharge):** Fox River
Watershed Area (including off-site runoff traveling through project area): 1.42 Acres

Watershed Data Summary. The following table summarizes the watershed data used to determine peak flows required to design the underground detention tank.

Summary Data Elements	Watershed information			
	Pre-develop E-1	Post-develop P-1	Post-develop P-2	Post-develop P-3 (offsite)
Watershed Areas (<i>in acres</i>) <i>(see attached map)</i>	1.33 acres	0.88 acres	0.45 acres	0.09 acres
Average Watershed Slopes (%)	2%	2%	20%	20%
Land Uses (% of each) <i>(see attached map)</i>	44% Pervious 56% Impervious	6% Pervious 94% Impervious	45% Pervious 55% Impervious	100% Pervious
Runoff Curve Numbers	RCN = 90	RCN = 97	RCN = 90	RCN = 80
Conveyance Systems Types	Storm Sewer & Sheet Flow	Storm Sewer	Storm Sewer & Sheet Flow	Storm Sewer
Time of Concentration (<i>T_c</i>) <i>Min value per TR-55</i>	6 mins	6 mins	6 mins	6 mins
2-yr./24 hour Peak Flow	3.99 cfs	3.32 cfs	1.34 cfs	0.17 cfs
10-yr./24 hour Peak Flow	6.24 cfs	4.76 cfs	2.10 cfs	0.32 cfs
100-yr./24 hour Peak Flow	11.01 cfs	7.82 cfs	3.70 cfs	0.65 cfs

Exhibit D (continued)

Practice Design Summary. The following table summarizes the data used to design the underground detention tank.

Design Element	Design Data
Site assessment data:	
Contributing drainage area to basin (watershed P-1)	0.88 acres
Distance to nearest private well (including off-site wells)	> 100 feet
Distance to municipal well (including off-site wells)	> 1200 feet
Wellhead protection area involved?	No
Ground slope	average 2%
Any buried or overhead utilities in the area?	No
Proposed outfall conveyance system/discharge (w/ distances)	150 ft. of storm sewer to public sewer
Any downstream roads or other structures? (describe)	Yes, public storm sewer in Gascoigne Road
Floodplain, shoreland or wetlands?	No
General basin design data :	
Underground Detention Tank Data	130 ft Long, 7 ft Diameter
Permanent Pool Depth	3.5 ft
Design permanent pool water surface elevation	elev. 109.75
Underground Detention Tank Invert	Elev. 106.25
Sediment storage depth & design maintenance	0.5 ft. depth of sediment

Design Basin Inflow, Outflow & Storage Data				
Inflow Peak (not including offsite flow)	Maximum Outflow Rate	Max. Water Elevation	Storage Volume at Max. Elev. (above perm. pool)	Outflow Control Structures*
3.32 cfs (Post 2-yr./24 hr. peak)	2.54 cfs	110.85 ft.	3,484 Cubic Ft	#1
4.76 cfs (Post 10-yr./24 hr. peak)	3.44 cfs	111.38 ft.	3,920 Cubic Ft	#1
7.82 cfs (Post 100-yr./24 hr. peak)	5.62 cfs	112.84 ft.	4,878 Cubic Ft	#1 and #2

* #1 = 11 inch orifice in weir plate @ 109.75

#2 = 6 foot wide weir plate @ 112.00

Exhibit D (continued)

Watershed Map. The watershed map shown below was used to determine the post-development data contained in this exhibit. The post-developed watershed areas are the same as the pre-development watershed areas for this project.

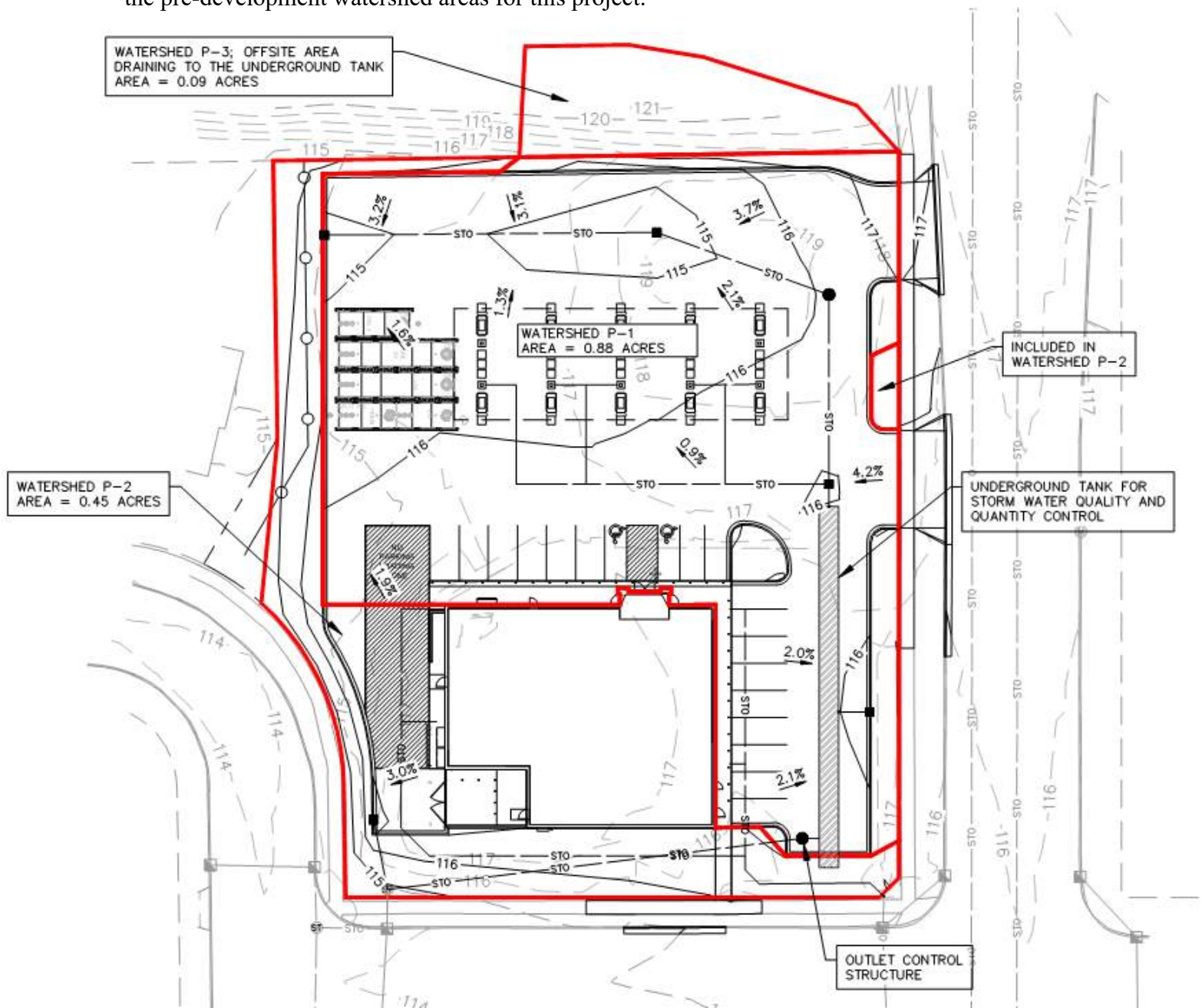
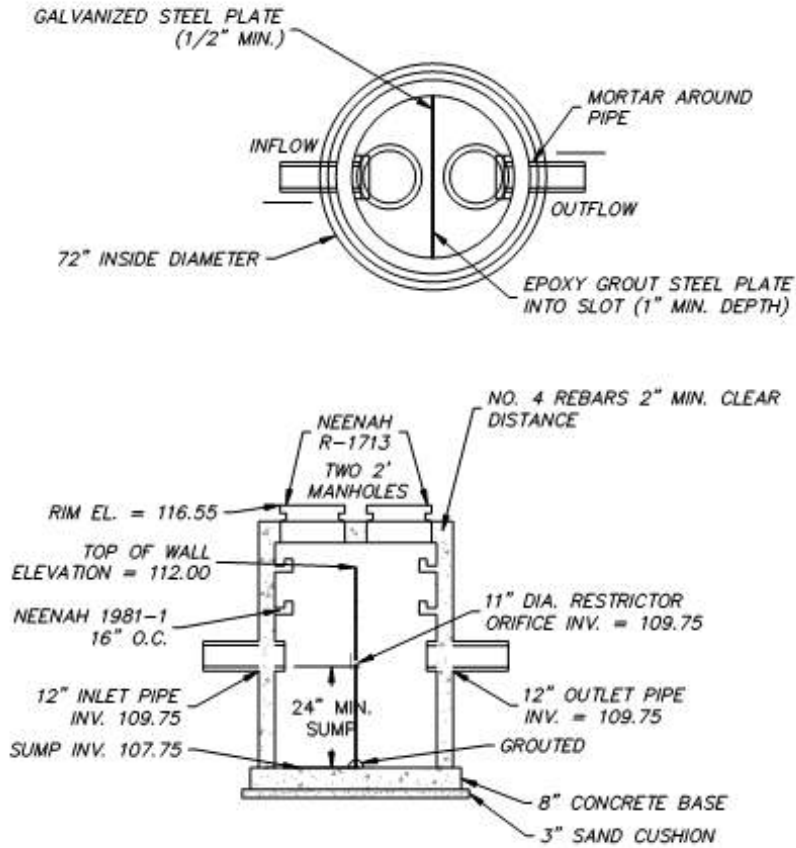

Exhibit E
As-built Survey for Underground Detention Tank

The underground detention tank depicted in Figure 1 is a reduced copy of the as-built plan.

Project Identifier: **Kwik Trip #527**
Storm water Practice: **Underground Detention Tank**
Location of Practices: **Parcel described in Exhibit A**
Owners of Parcel: **Kwik Trip, Inc.**

Exhibit E
Figure 2 – Storm Water Practices Details



- NOTES:**
1. STRUCTURE SHALL BE CONSTRUCTED CONFORMING TO THE REQUIREMENTS OF ASTM C-478.
 2. REINFORCING STEEL NOT SHOWN

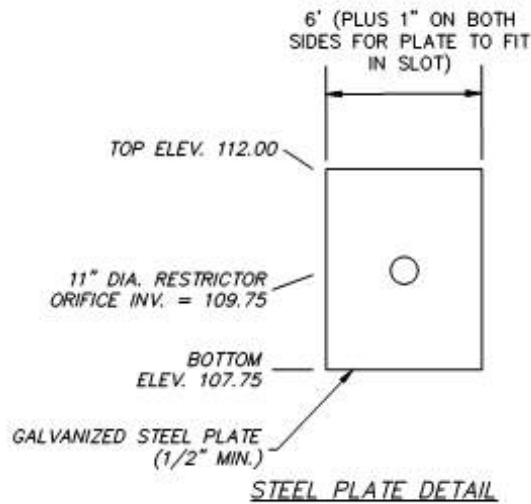

OUTLET CONTROL STRUCTURE – MH 320

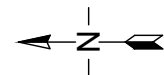

NORTH ARROW PROVIDED FOR REFERENCE ONLY, REFER TO ENGINEERED SITE PLANS FOR EXACT LOCATION AND ORIENTATION

RISER INFORMATION		
PIECE	RIM ELEV.	SYSTEM INVERT
36"Ø RISER A3	115.85	106.25
36"Ø RISER C2	116.55	106.25

STUB INFORMATION		
PIECE	STUB INVERT	SYSTEM INVERT
18"Ø STUB A2	109.75	106.25
12"Ø STUB B1	109.75	106.25
12"Ø STUB C3	109.75	106.25

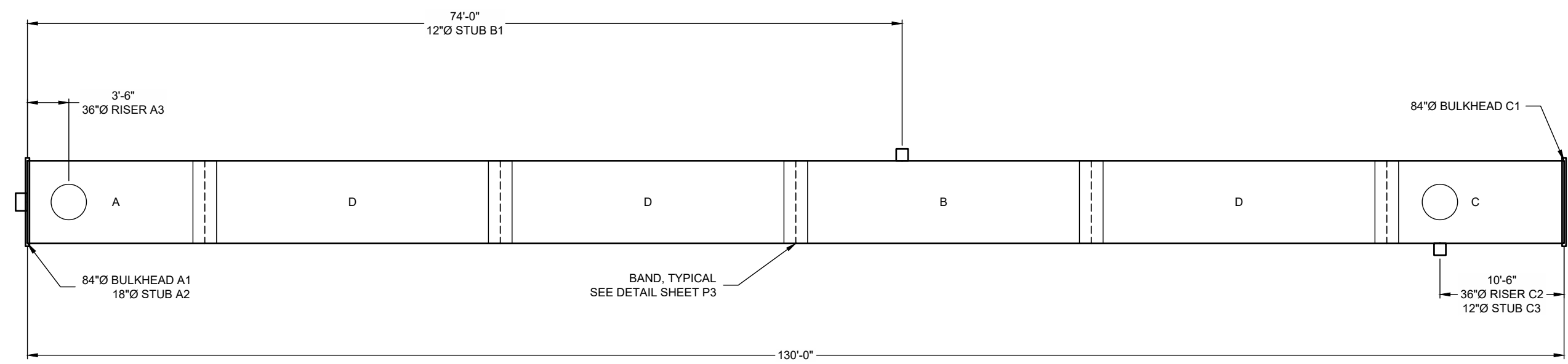

THE UNDERSIGNED HEREBY APPROVES THE ATTACHED (4) PAGES INCLUDING THE FOLLOWING:

- PIPE STORAGE = 5,003 CF
- MAINLINE PIPE GAGE = 16
- WALL TYPE = SOLID
- DIAMETER = 84"
- FINISH = ALT2
- CORRUGATION = 5x1

CUSTOMER _____ DATE _____

ASSEMBLY
 SCALE: 1" = 10'
 PIPE STORAGE: 5,003 CF
 LOADING: H20
 PIPE INV. = 106.25'±

- NOTES**
- ALL RISER AND STUB DIMENSIONS ARE TO CENTERLINE.
 - ALL ELEVATIONS, DIMENSIONS, AND LOCATIONS OF RISERS AND INLETS, SHALL BE VERIFIED BY THE ENGINEER OF RECORD (EOR) PRIOR TO RELEASING FOR FABRICATION.
 - ALL FITTINGS AND REINFORCEMENT COMPLY WITH ASTM A998.
 - ALL RISERS AND STUBS ARE 2½" x ½" CORRUGATION AND 16 GAGE UNLESS OTHERWISE NOTED.
 - RISERS TO BE FIELD TRIMMED TO GRADE AS REQUIRED, BY CONTRACTOR.
 - QUANTITY OF PIPE SHOWN DOES NOT PROVIDE EXTRA PIPE FOR CONNECTING THE SYSTEM TO EXISTING PIPE OR DRAINAGE STRUCTURES. OUR SYSTEM AS DETAILED PROVIDES NOMINAL INLET AND/OR OUTLET PIPE STUB FOR CONNECTION TO EXISTING DRAINAGE FACILITIES. IF ADDITIONAL PIPE IS NEEDED IT IS THE RESPONSIBILITY OF THE CONTRACTOR.
 - ALL ACCESS CASTINGS ARE THE RESPONSIBILITY OF THE CONTRACTOR AND ARE NOT SUPPLIED BY CONTECH.

I:\MERLIN\PROJECTS\ACTIVE\641385-10\CMP DETENTION\DRAWINGS\641385-010\CMP CONFAB.DWG 2/25/2020 3:52 PM

The design and information shown on this drawing is provided as a service to the project owner, engineer and contractor by Contech Engineered Solutions LLC ("Contech"). Neither this drawing, nor any part thereof, may be used, reproduced or modified in any manner without the prior written consent of Contech. Failure to comply is done at the user's own risk and Contech expressly disclaims any liability or responsibility for such use.

If discrepancies between the supplied information upon which the drawing is based and actual field conditions are encountered as site work progresses, these discrepancies must be reported to Contech immediately for re-evaluation of the design. Contech accepts no liability for designs based on missing, incomplete or inaccurate information supplied by others.

MARK	DATE	REVISION DESCRIPTION	BY

CONTECH
 ENGINEERED SOLUTIONS LLC
 www.ContechES.com
 7037 Ridge Road, Hanover, MD 21076
 866-740-3318 410-796-5505 866-376-8511 FAX

CONTECH
 CMP DETENTION SYSTEMS
 CONTECH PROPOSAL DRAWING

84"Ø UNDERGROUND DETENTION SYSTEM - 641385-010
 KWIK TRIP #527
 PEWAUKEE, WI
 SITE DESIGNATION: UNDERGROUND STORM WATER TANK

PROJECT No.: 641385	SEQ. No.: 010	DATE: 2/25/2020
DESIGNED: NDC	DRAWN: NDC	
CHECKED: NDC	APPROVED:	
SHEET NO.: P1 OF 4		

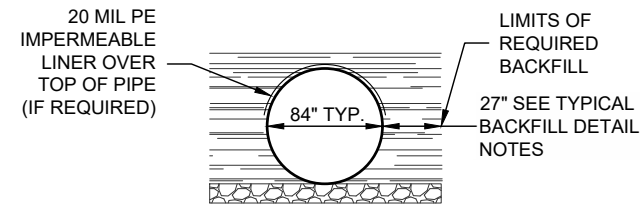

TYPICAL SECTION VIEW
NOT TO SCALE

NOTE: IF SALTING AGENTS FOR SNOW AND ICE REMOVAL ARE USED ON OR NEAR THE PROJECT, A GEOMEMBRANE BARRIER IS RECOMMENDED WITH THE SYSTEM. THE GEOMEMBRANE LINER IS INTENDED TO HELP PROTECT THE SYSTEM FROM THE POTENTIAL ADVERSE EFFECTS THAT MAY RESULT FROM A CHANGE IN THE SURROUNDING ENVIRONMENT OVER A PERIOD OF TIME. PLEASE REFER TO THE CORRUGATED METAL PIPE DETENTION DESIGN GUIDE FOR ADDITIONAL INFORMATION.

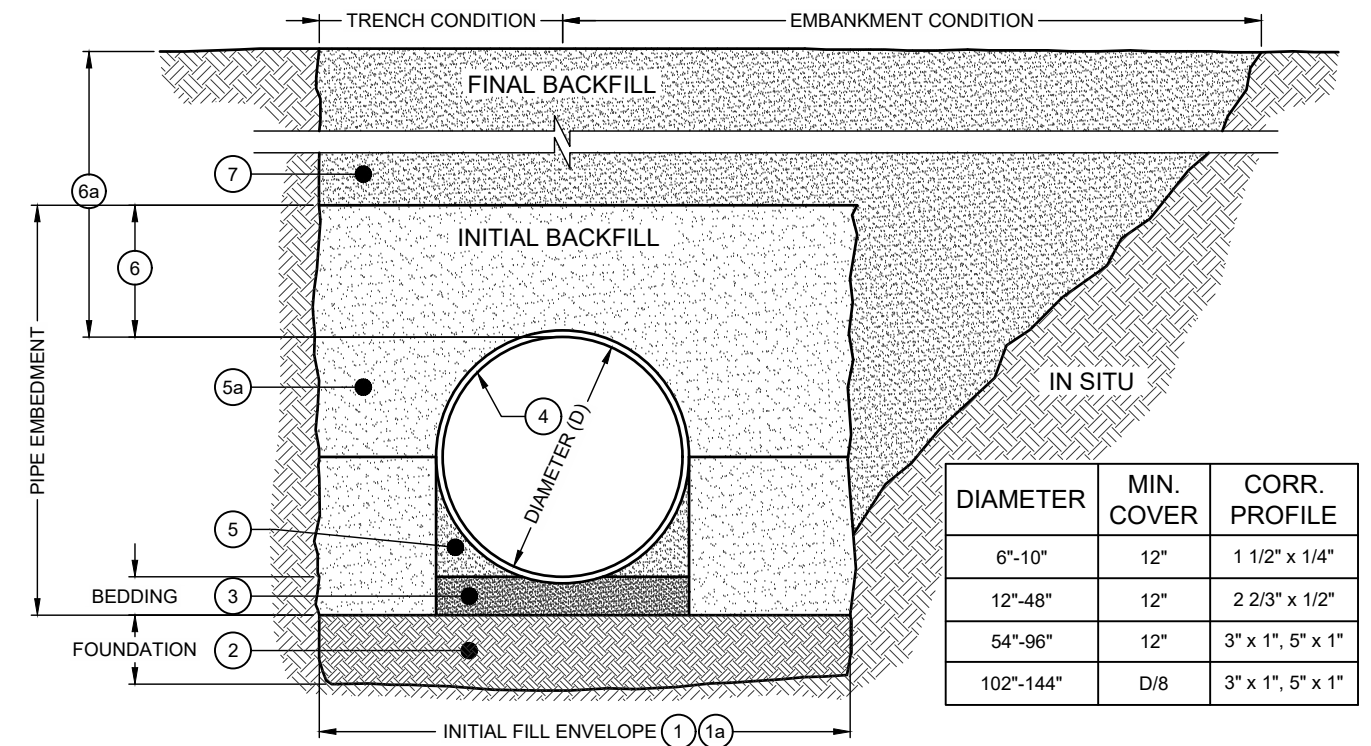

DIAMETER	MIN. COVER	CORR. PROFILE
6"-10"	12"	1 1/2" x 1/4"
12"-48"	12"	2 2/3" x 1/2"
54"-96"	12"	3" x 1", 5" x 1"
102"-144"	D/8	3" x 1", 5" x 1"

BACKFILL REQUIREMENTS FOLLOW THE GUIDELINES OF AASHTO LRFD BRIDGE DESIGN (SEC 12) AND CONSTRUCTION (SEC 26)

- 1 MINIMUM TRENCH WIDTH MUST ALLOW ROOM FOR PROPER COMPACTION OF HAUNCH MATERIALS UNDER THE PIPE. THE MINIMUM TRENCH WIDTH (12.6.6.1):
PIPE ≤ 12": D + 16"
PIPE > 12": 1.5D + 12"
- 1a MINIMUM EMBANKMENT WIDTH (IN FEET) FOR INITIAL FILL ENVELOPE (12.6.6.2):
PIPE < 24": 3.0D
PIPE 24" - 144": D + 4'0"
PIPE > 144": D + 10'0"
- 2 THE FOUNDATION UNDER THE PIPE AND SIDE BACKFILL SHALL BE ADEQUATE TO SUPPORT THE LOADS ACTING UPON IT (26.5.2).
- 3 ENGINEER TO DETERMINE IF BEDDING IS REQUIRED. BEDDING MATERIAL SHALL BE A RELATIVELY LOOSE MATERIAL THAT IS ROUGHLY SHAPED TO FIT THE BOTTOM OF THE PIPE, AND A MINIMUM OF TWICE THE CORRUGATION DEPTH IN THICKNESS, WITH THE MAXIMUM PARTICLE SIZE OF ONE-HALF OF THE CORRUGATION DEPTH (26.3.8.1, 26.5.3).
- 4 CORRUGATED STEEL PIPE (CSP / HEL-COR).
- 5 HAUNCH ZONE MATERIAL SHALL BE HAND SHOVELED OR SHOVEL SLICED INTO PLACE TO ALLOW FOR PROPER COMPACTION (26.5.4).
- 5a INITIAL BACKFILL FOR PIPE EMBEDMENT TO MEET AASHTO A-1, A-2 OR A-3 CLASSIFICATION, OR APPROVED EQUAL, COMPACTED TO 90% STANDARD PROCTOR (T 99). MAXIMUM PARTICLE SIZE NOT TO EXCEED 3" (12.4.1.2). ALL LIFTS PLACED IN A CONTROLLED MANNER. IT IS RECOMMENDED THAT LIFTS NOT EXCEED AN 8" UNCOMPACTED LIFT HEIGHT TO PREVENT UNEVEN LOADING, AND THE LESSER OF 1/3 THE DIAMETER OR 24" AS THE MAXIMUM DIFFERENTIAL SIDE-TO-SIDE (26.5.4).
- 6 INITIAL BACKFILL ABOVE PIPE MAY INCLUDE ROAD BASE MATERIAL (AND RIGID PAVEMENT IF APPLICABLE). SEE TABLE ABOVE.
- 6a TOTAL HEIGHT OF COMPACTED COVER FOR CONVENTIONAL HIGHWAY LOADS IS MEASURED FROM TOP OF PIPE TO BOTTOM OF FLEXIBLE PAVEMENT OR TOP OF RIGID PAVEMENT (12.6.6.3).
- 7 FINAL BACKFILL MATERIAL SELECTION AND COMPACTION REQUIREMENTS SHALL FOLLOW THE PROJECT PLANS AND SPECIFICATIONS PER THE ENGINEER OF RECORD (26.5.4.1).

NOTES:

- ENGINEER TO DETERMINE IF GEOTEXTILE SHOULD BE USED TO PREVENT SOIL MIGRATION INTO VARYING SOIL TYPES (PROJECT ENGINEER).
- FOR MULTIPLE BARREL INSTALLATIONS THE RECOMMENDED STANDARD SPACING BETWEEN PARALLEL PIPE RUNS SHALL BE PIPE DIA./2 BUT NO LESS THAN 12", OR 36" FOR PIPE DIAMETERS 72" AND LARGER.
- CONTACT YOUR CONTECH REPRESENTATIVE FOR NONSTANDARD SPACING (TABLE C12.6.7-1).

TYPICAL BACKFILL DETAIL
NOT TO SCALE

I:\MERLIN\PROJECT\ACTIVE\641385-010\CMP DETENTION\DRAWINGS\641385-010\CMP CONFAB.DWG 2/25/2020 3:52 PM

The design and information shown on this drawing is provided as a service to the project owner, engineer and contractor by Contech Engineered Solutions LLC ("Contech"). Neither this drawing, nor any part thereof, may be used, reproduced or modified in any manner without the prior written consent of Contech. Failure to comply is done at the user's own risk and Contech expressly disclaims any liability or responsibility for such use.

If discrepancies between the supplied information upon which the drawing is based and actual field conditions are encountered as site work progresses, these discrepancies must be reported to Contech immediately for re-evaluation of the design. Contech accepts no liability for designs based on missing, incomplete or inaccurate information supplied by others.

MARK	DATE	REVISION DESCRIPTION	BY

CONTECH
ENGINEERED SOLUTIONS LLC
www.ContechES.com
7037 Ridge Road, Hanover, MD 21076
866-740-3318 410-796-5505 866-376-8511 FAX

CONTECH
CMP DETENTION SYSTEMS
CONTECH
PROPOSAL
DRAWING

84"Ø UNDERGROUND DETENTION SYSTEM - 641385-010
KWIK TRIP #527
PEWAUKEE, WI
SITE DESIGNATION: UNDERGROUND STORM WATER TANK

PROJECT No.: 641385	SEQ. No.: 010	DATE: 2/25/2020
DESIGNED: NDC	DRAWN: NDC	
CHECKED: NDC	APPROVED:	
SHEET NO.:	P2	OF 4

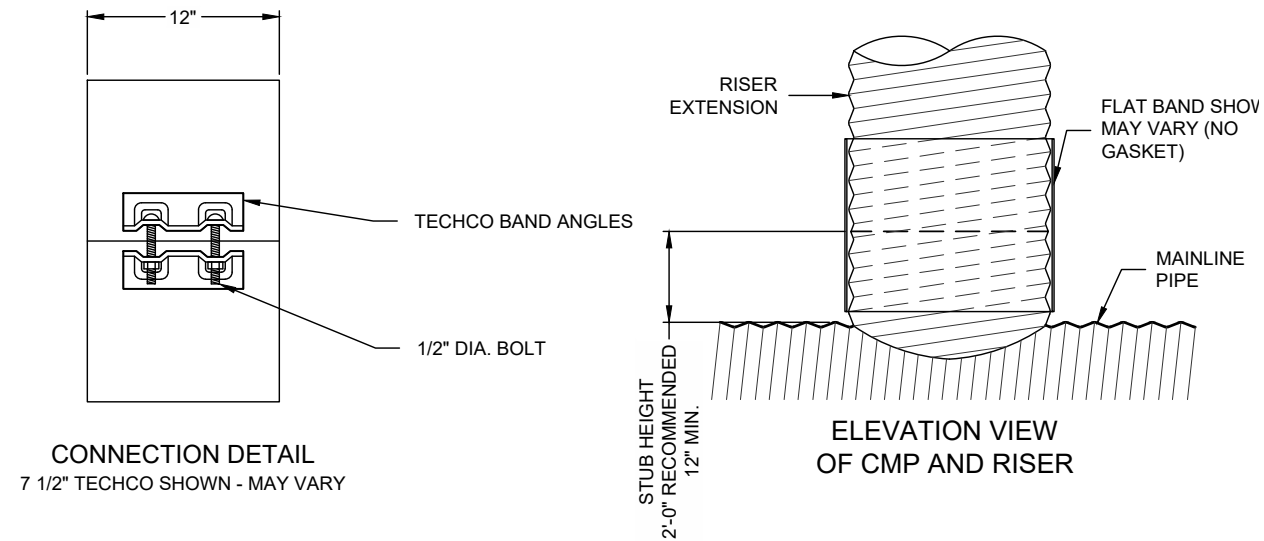

PLAIN END CMP RISER PIPE

GENERAL NOTES:

1. DELIVERED BAND STYLE AND FASTENER TYPE MAY VARY BY FABRICATION PLANT.
2. JOINT IS TO BE ASSEMBLED PER AASHTO BRIDGE CONSTRUCTION SPECIFICATION SEC 26.4.2.4.
3. BAND MATERIAL AND GAGE TO BE SAME AS RISER MATERIAL.
4. IF RISER HAS A HEIGHT OF COVER OF 10' OR MORE, USE A SLIP JOINT.
5. BANDS ARE NORMALLY FURNISHED AS FOLLOWS:
 - 12" THRU 48" 1-PIECE
 - 54" 2-PIECES
6. ALL RISER JOINT COMPONENTS WILL BE FIELD ASSEMBLED.
7. MANHOLE RISERS IN APPLICATIONS WHERE TRAFFIC LOADS ARE IMPOSED REQUIRE SPECIAL DESIGN CONSIDERATIONS.
8. DIMENSIONS SUBJECT TO MANUFACTURING TOLERANCES.

12" RISER BAND DETAIL
NOT TO SCALE

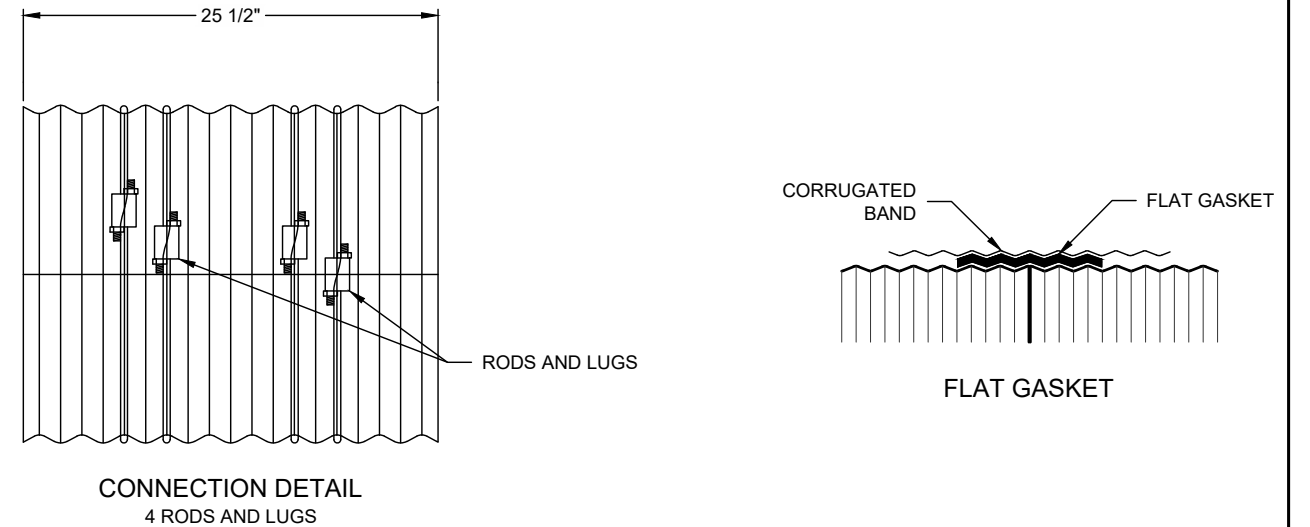

2 2/3"x1/2" RIVETED PIPE

GENERAL NOTES:

1. JOINT IS TO BE ASSEMBLED PER AASHTO BRIDGE CONSTRUCTION SPECIFICATION SEC 26.4.2.4.
2. BAND MATERIALS AND/OR COATING CAN VARY BY LOCATION. CONTACT YOUR CONTECH REPRESENTATIVE FOR AVAILABILITY.
3. BANDS ARE SHAPED TO MATCH THE PIPE-ARCH WHEN APPLICABLE.
4. BANDS ARE NORMALLY FURNISHED AS FOLLOWS:
 - 12" THRU 48" 1-PIECE
 - 54" THRU 96" 2-PIECES
 - 102" THRU 144" 3-PIECES
5. BAND FASTENERS ARE ATTACHED WITH SPOT WELDS, RIVETS OR HAND WELDS.
6. ALL CMP IS REROLLED TO HAVE ANNULAR END CORRUGATIONS OF 2 2/3"x1/2"
7. DIMENSIONS ARE SUBJECT TO MANUFACTURING TOLERANCES.
8. ORDER SHALL DESIGNATE GASKET OPTION, IF REQUIRED (SEE DETAILS ABOVE).

10-C BAND DETAIL
NOT TO SCALE

I:\MERLIN\PROJECTS\ACTIVE\641385-010\CMP DETENTION\DRAWINGS\641385-010\CMP CON FAB.DWG 2/25/2020 3:53 PM

The design and information shown on this drawing is provided as a service to the project owner, engineer and contractor by Contech Engineered Solutions LLC ("Contech"). Neither this drawing, nor any part thereof, may be used, reproduced or modified in any manner without the prior written consent of Contech. Failure to comply is done at the user's own risk and Contech expressly disclaims any liability or responsibility for such use.

If discrepancies between the supplied information upon which the drawing is based and actual field conditions are encountered as site work progresses, these discrepancies must be reported to Contech immediately for re-evaluation of the design. Contech accepts no liability for designs based on missing, incomplete or inaccurate information supplied by others.

MARK	DATE	REVISION DESCRIPTION	BY

CONTECH
ENGINEERED SOLUTIONS LLC
www.ContechES.com
7037 Ridge Road, Hanover, MD 21076
866-740-3318 410-796-5505 866-376-8511 FAX

CONTECH
CMP DETENTION SYSTEMS
CONTECH PROPOSAL DRAWING

84"Ø UNDERGROUND DETENTION SYSTEM - 641385-010
KWIK TRIP #527
PEWAUKEE, WI
SITE DESIGNATION: UNDERGROUND STORM WATER TANK

PROJECT No.: 641385	SEQ. No.: 010	DATE: 2/25/2020
DESIGNED: NDC	DRAWN: NDC	
CHECKED: NDC	APPROVED:	
SHEET NO.: P3 OF 4		

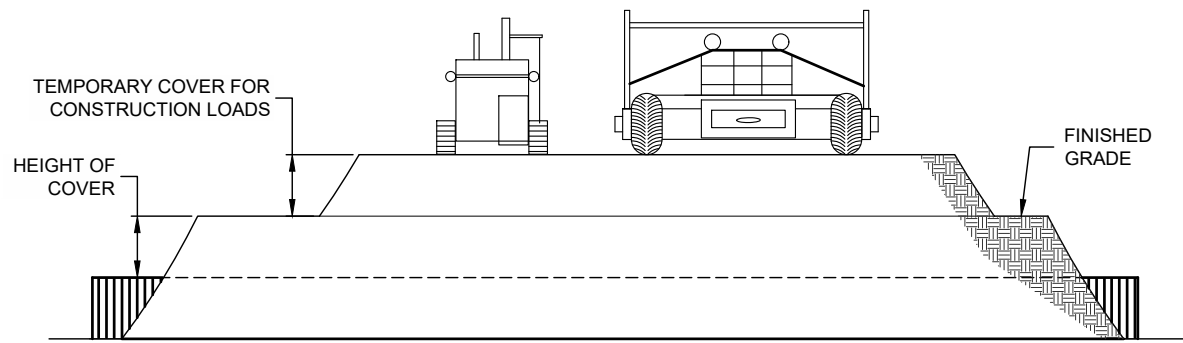

CONSTRUCTION LOADS

FOR TEMPORARY CONSTRUCTION VEHICLE LOADS, AN EXTRA AMOUNT OF COMPACTED COVER MAY BE REQUIRED OVER THE TOP OF THE PIPE. THE HEIGHT-OF-COVER SHALL MEET THE MINIMUM REQUIREMENTS SHOWN IN THE TABLE BELOW. THE USE OF HEAVY CONSTRUCTION EQUIPMENT NECESSITATES GREATER PROTECTION FOR THE PIPE THAN FINISHED GRADE COVER MINIMUMS FOR NORMAL HIGHWAY TRAFFIC.

PIPE SPAN, INCHES	AXLE LOADS (kips)			
	18-50	50-75	75-110	110-150
	MINIMUM COVER (FT)			
12-42	2.0	2.5	3.0	3.0
48-72	3.0	3.0	3.5	4.0
78-120	3.0	3.5	4.0	4.0
126-144	3.5	4.0	4.5	4.5

*MINIMUM COVER MAY VARY, DEPENDING ON LOCAL CONDITIONS. THE CONTRACTOR MUST PROVIDE THE ADDITIONAL COVER REQUIRED TO AVOID DAMAGE TO THE PIPE. MINIMUM COVER IS MEASURED FROM THE TOP OF THE PIPE TO THE TOP OF THE MAINTAINED CONSTRUCTION ROADWAY SURFACE.

CONSTRUCTION LOADING DIAGRAM
NOT TO SCALE

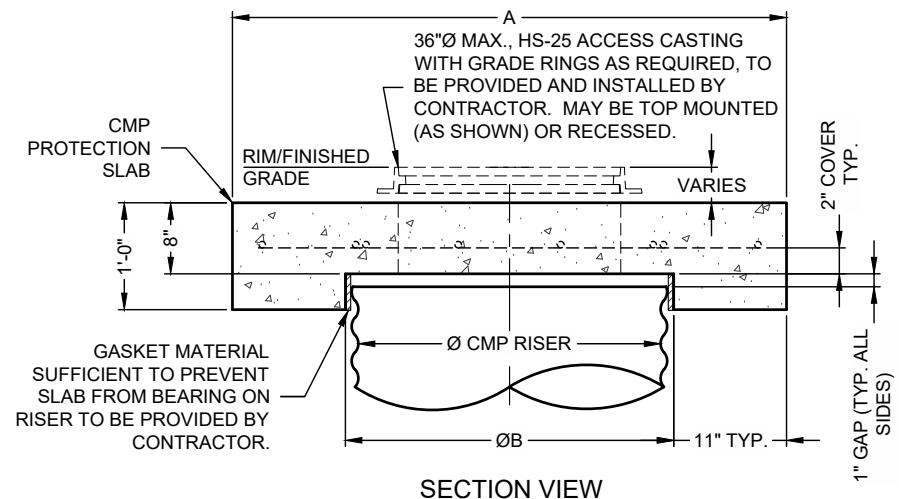

SECTION VIEW

REINFORCING TABLE				
Ø CMP RISER	A	B Ø	REINFORCING	**BEARING PRESSURE (PSF)
24"	4'Ø 4'x4'	26"	#5 @ 10" OCEW #5 @ 10" OCEW	2,540 1,900
30"	4'-6"Ø 4'-6" x 4'-6"	32"	#5 @ 10" OCEW #5 @ 9" OCEW	2,260 1,670
36"	5'Ø 5' x 5'	38"	#5 @ 9" OCEW #5 @ 8" OCEW	2,060 1,500
42"	5'-6"Ø 5'-6" x 5'-6"	44"	#5 @ 8" OCEW #5 @ 8" OCEW	1,490 1,370
48"	6'Ø 6' x 6'	50"	#5 @ 7" OCEW #5 @ 7" OCEW	1,210 1,270

** ASSUMED SOIL BEARING CAPACITY

ACCESS CASTING NOT SUPPLIED BY CONTECH

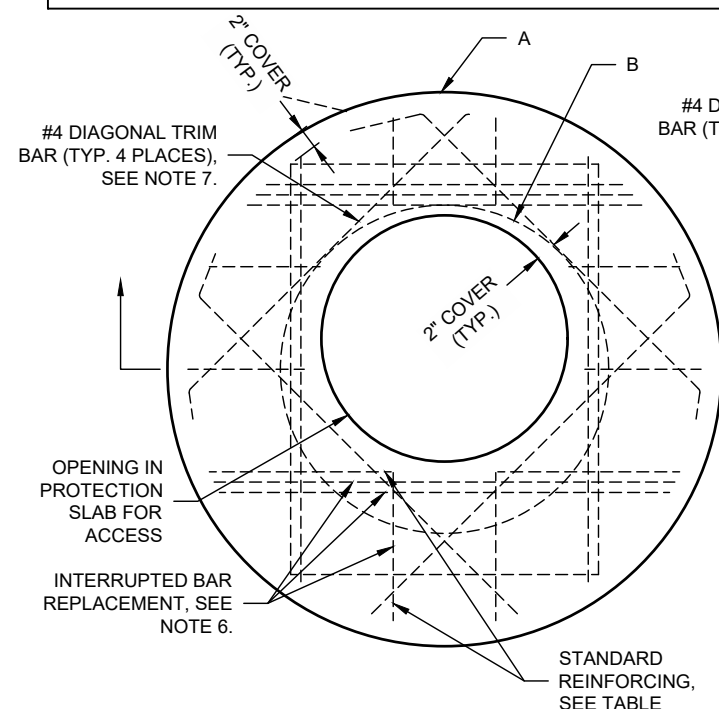

ROUND OPTION PLAN VIEW

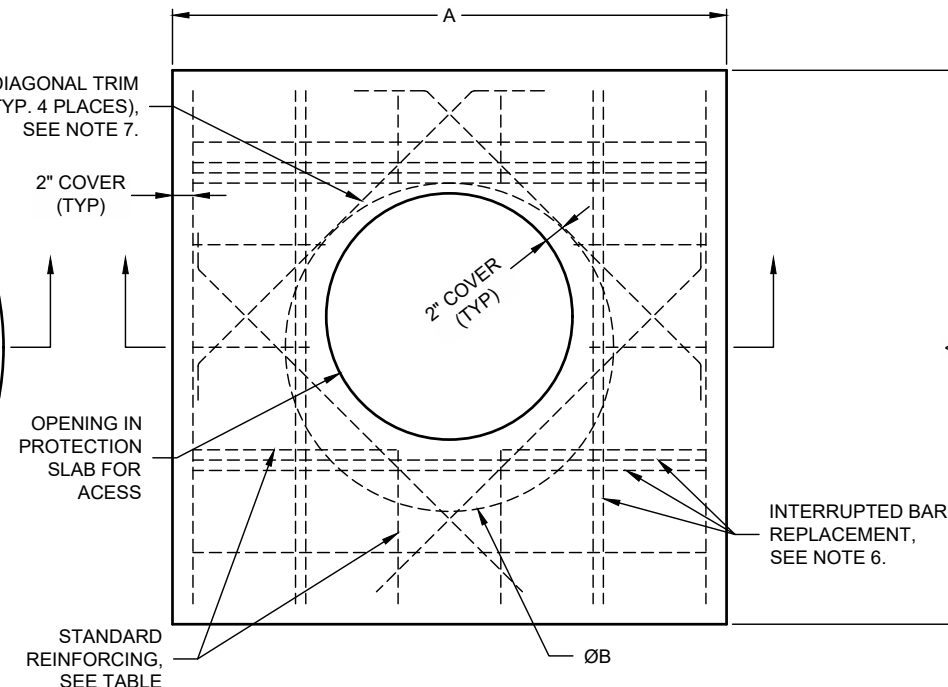

SQUARE OPTION PLAN VIEW

NOTES:

- DESIGN IN ACCORDANCE WITH AASHTO, 17th EDITION AND ACI 350.
- DESIGN LOAD HS25.
- EARTH COVER = 1' MAX.
- CONCRETE STRENGTH = 4,000 psi
- REINFORCING STEEL = ASTM A615, GRADE 60.
- PROVIDE ADDITIONAL REINFORCING AROUND OPENINGS EQUAL TO THE BARS INTERRUPTED, HALF EACH SIDE. ADDITIONAL BARS TO BE IN THE SAME PLANE.
- TRIM OPENING WITH DIAGONAL #4 BARS, EXTEND BARS A MINIMUM OF 12" BEYOND OPENING, BEND BARS AS REQUIRED TO MAINTAIN BAR COVER.
- PROTECTION SLAB AND ALL MATERIALS TO BE PROVIDED AND INSTALLED BY CONTRACTOR.
- DETAIL DESIGN BY DELTA ENGINEERS, ARCHITECTS AND LAND SURVEYORS, ENDWELL, NY.

MANHOLE CAP DETAIL
NOT TO SCALE

SPECIFICATION FOR CORRUGATED STEEL PIPE-ALUMINIZED TYPE 2 STEEL

SCOPE

THIS SPECIFICATION COVERS THE MANUFACTURE AND INSTALLATION OF THE CORRUGATED STEEL PIPE (CSP) DETAILED IN THE PROJECT PLANS.

MATERIAL

THE ALUMINIZED TYPE 2 STEEL COILS SHALL CONFORM TO THE APPLICABLE REQUIREMENTS OF AASHTO M274 OR ASTM A929.

PIPE

THE CSP SHALL BE MANUFACTURED IN ACCORDANCE WITH THE APPLICABLE REQUIREMENTS OF AASHTO M36 OR ASTM A760. THE PIPE SIZES, GAGES AND CORRUGATIONS SHALL BE AS SHOWN ON THE PROJECT PLANS.

ALL FABRICATION OF THE PRODUCT SHALL OCCUR WITHIN THE UNITED STATES.

HANDLING AND ASSEMBLY

SHALL BE IN ACCORDANCE WITH RECOMMENDATIONS OF THE NATIONAL CORRUGATED STEEL PIPE ASSOCIATION (NCSPA)

INSTALLATION

SHALL BE IN ACCORDANCE WITH AASHTO STANDARD SPECIFICATIONS FOR HIGHWAY BRIDGES, SECTION 26, DIVISION II OR ASTM A798 AND IN CONFORMANCE WITH THE PROJECT PLANS AND SPECIFICATIONS. IF THERE ARE ANY INCONSISTENCIES OR CONFLICTS THE CONTRACTOR SHOULD DISCUSS AND RESOLVE WITH THE SITE ENGINEER.

IT IS ALWAYS THE RESPONSIBILITY OF THE CONTRACTOR TO FOLLOW OSHA GUIDELINES FOR SAFE PRACTICES.

MATERIAL SPECIFICATION
NOT TO SCALE

MARK	DATE	REVISION DESCRIPTION	BY

The design and information shown on this drawing is provided as a service to the project owner, engineer and contractor by Contech Engineered Solutions LLC ("Contech"). Neither this drawing, nor any part thereof, may be used, reproduced or modified in any manner without the prior written consent of Contech. Failure to comply is done at the user's own risk and Contech expressly disclaims any liability or responsibility for such use.

If discrepancies between the supplied information upon which the drawing is based and actual field conditions are encountered as site work progresses, these discrepancies must be reported to Contech immediately for re-evaluation of the design. Contech accepts no liability for designs based on missing, incomplete or inaccurate information supplied by others.

CONTECH
ENGINEERED SOLUTIONS LLC
www.ContechES.com
7037 Ridge Road, Hanover, MD 21076
866-740-3318 410-796-5505 866-376-8511 FAX

CONTECH
CMP DETENTION SYSTEMS
CONTECH PROPOSAL DRAWING

84"Ø UNDERGROUND DETENTION SYSTEM - 641385-010
KWIK TRIP #527
PEWAUKEE, WI
SITE DESIGNATION: UNDERGROUND STORM WATER TANK

PROJECT No.: 641385	SEQ. No.: 010	DATE: 2/25/2020
DESIGNED: NDC	DRAWN: NDC	
CHECKED: NDC	APPROVED: 	
SHEET NO.: P4		OF 4

I:\MERLIN\PROJECT\ACTIVE\641385-010\CMP DETENTION\DRAWINGS\641385-010\CMP CONFINED.DWG 2/25/2020 3:53 PM

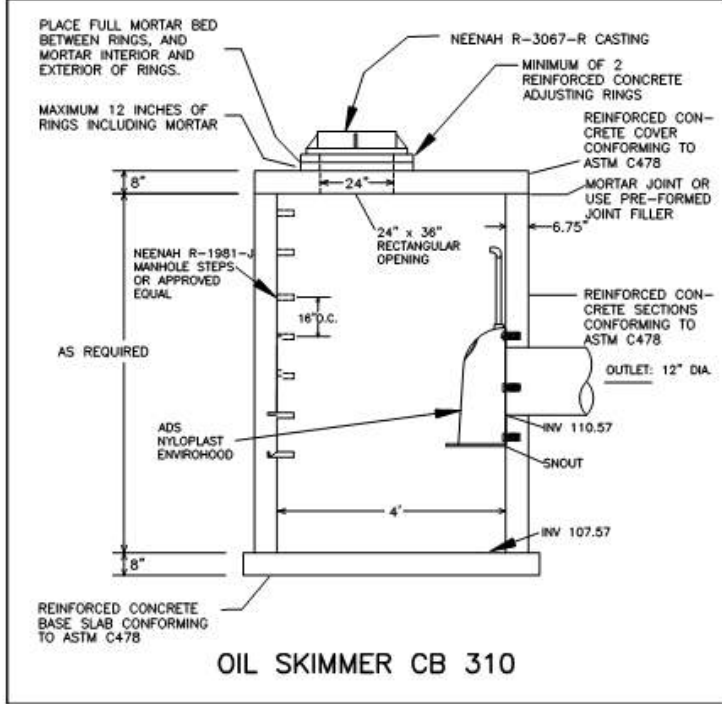
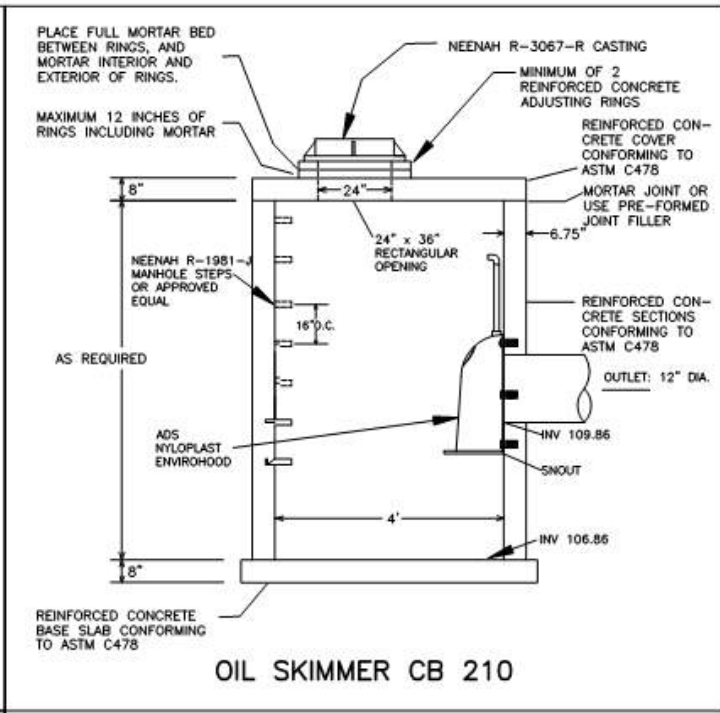
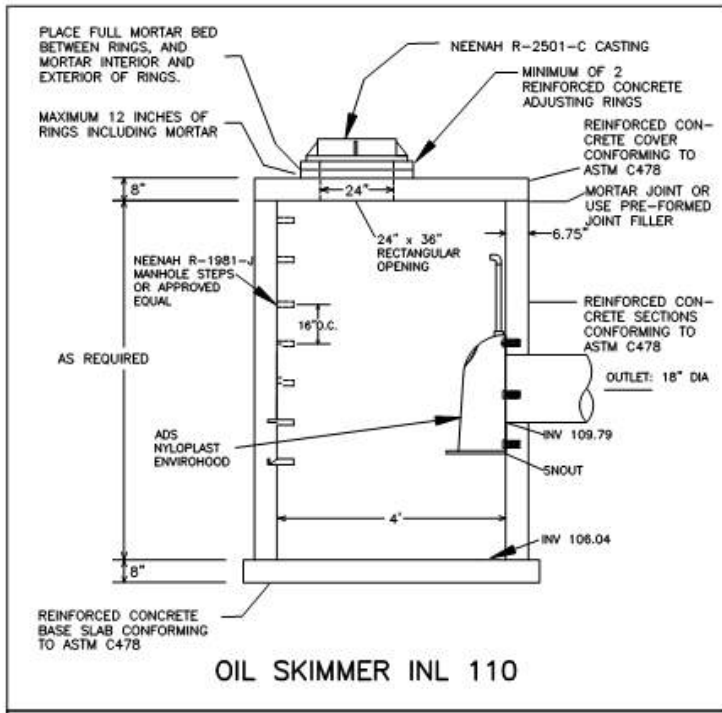

Exhibit "F"
Engineering/Construction Verification

DATE: _____

TO: City of Waukesha

FROM: _____ [Project Engineer's Name/Company]

RE: Engineering/Construction Verification for the following project:
Project Name: _____
Section _____, Town of _____
Storm Water Management & Erosion Control Permit # _____
Storm Water Management Practices: _____

For the above-referenced project and storm water management practices, this correspondence shall serve as verification that: 1) all site inspections outlined in approved inspection plans have been successfully completed; and 2) the storm water management practice design data presented in Exhibit D, and the "as-built" construction documentation presented in Exhibit E comply with all applicable state and local technical standards, in accordance with the City of Waukesha Storm Water Management and Erosion Control Ordinance.

[Must include one of the following two statements:]

1. Any variations from the originally approved construction plans are noted in Exhibit E. These variations are considered to be within the tolerances of standard construction techniques and do not affect the original design as presented in Exhibit D in any way.

[Note: The City may request additional documentation to support this statement depending on the extent of deviations from the approved plans.]

Or

2. Any design or construction changes from the originally approved construction plans are documented in Exhibits D and E and have been approved by the City of Waukesha.

[Note: If warm season and wetland planting verification is required, it may be included in this exhibit.]

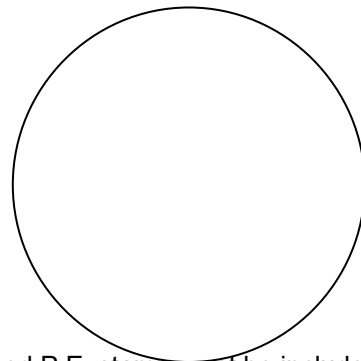

(Signed P.E. stamp must be included)

Exhibit G
Storm Water Management and Erosion Control Permit Termination

Project Identifier: Kwik Trip #527

Location: Parcel per CSM # _____

Storm Water Management and Erosion Control Permit Holder's Name: Kwik Trip, Inc.

Storm Water Management & Erosion Control Permit #: _____

Chapter 32 – City of Waukesha Storm Water Management and Erosion Control requires that all newly constructed storm water management practices be maintained by the Storm Water and Erosion Control Permit Holder until permit termination, after which maintenance responsibilities shall be transferred to the responsible party identified on the subdivision plat [or CSM] and referenced in this Maintenance Agreement.

Upon execution below, this exhibit shall serve to certify that the Storm Water Permit Holder has satisfied all requirements of the Storm Water Management and Erosion Control Ordinance and that the City of Waukesha has terminated the Storm Water Management and Erosion Control Permit for the property covered by this Maintenance Agreement.

Dated this ___ day of _____, 201_.

City of Waukesha representative:

(Signature)

(Typed Name and Title)

Acknowledgements

State of Wisconsin
County of Waukesha

Personally came before me this ___ day of _____, 201_, the above named _____ to me known to be the person who executed the foregoing instrument and acknowledged the same.

[Name]
Notary Public, Waukesha County, WI
My commission expires: _____