

PROJECT INFORMATION

WAUKESHA  
MEMORIAL  
HOSPITAL - NORTH  
WING  
RENOVATIONS

725 AMERICAN  
AVENUE,  
WAUKESHA, WI  
53188

ISSUANCE AND REVISIONS

DATE	DESCRIPTION
12/20/2018	PLAN COMMISSION SUBMITTAL

KEY PLAN

SHEET INFORMATION

PROGRESS DOCUMENTS  
NOT FOR CONSTRUCTION

These documents reflect progress and intent and may be subject to change, including additional detail. These are not final construction documents and shall not be used for final bidding or construction-related purposes.

PROJECT MANAGER

PROJECT NUMBER 418190

DETAILED SITE  
GRADING AND  
UTILITY PLAN

LEGEND

- PROPOSED CONCRETE CURB AND GUTTER
- PROPOSED HIGH SIDE CONCRETE CURB AND GUTTER
- PROPOSED FLUSH HIGH SIDE CONCRETE CURB AND GUTTER
- PROPOSED FLUSH CONCRETE CURB AND GUTTER
- EXISTING CONTOUR
- PROPOSED CONTOUR
- ELEVATION AT TOP OF RETAINING WALL
- ELEVATION AT BOTTOM OF RETAINING WALL
- SPOT ELEVATION
- TOP OF CURB ELEVATION
- BOTTOM OF CURB ELEVATION
- PROPOSED CATCH BASIN
- PROPOSED MANHOLE
- PROPOSED CURB RAMP

GENERAL NOTES

- THE BASE SURVEY WAS PREPARED BY JAHNKE & JAHNKE ASSOCIATES, INC. EXISTING CONDITIONS HAVE CHANGED SINCE THE INITIAL JAHNKE & JAHNKE SURVEY. ADDITIONAL SYMBOLS AND FEATURES HAVE BEEN ADDED TO REPRESENT APPROXIMATE EXISTING CONDITIONS. ALL UNDERGROUND UTILITIES AND STRUCTURES HAVE BEEN SHOWN TO A REASONABLE DEGREE OF ACCURACY AND IT SHALL BE THE CONTRACTOR'S RESPONSIBILITY TO VERIFY THEIR EXACT LOCATION AND TO AVOID DAMAGE THERETO.
- REFER TO JAHNKE & JAHNKE ASSOCIATES, INC. SURVEY FOR BENCHMARKS, DATUM, AND TOPOGRAPHIC ELEMENTS.
- CONTRACTOR SHALL VERIFY LOCATION OF WORK AND REPORT ANY DISCREPANCIES TO THE ENGINEER PRIOR TO COMMENCING WORK.

GRADING NOTES

- ADA REGULATIONS REQUIRE A MAXIMUM SLOPE OF 1:20 (5%) ALONG THE LENGTH OF THE ACCESSIBLE ROUTE AND A MAXIMUM SLOPE OF 1:50 (2%) ACROSS THE WIDTH OF THE ACCESSIBLE ROUTE. ADA REGULATIONS REQUIRE A MAXIMUM SLOPE OF 1:50 (2%) IN ALL DIRECTIONS WITHIN AN ADA PARKING STALL AND ADJACENT UNLOADING ZONE.
- RIM ELEVATIONS IN CURB AND GUTTER ARE FLANGE GRADES.

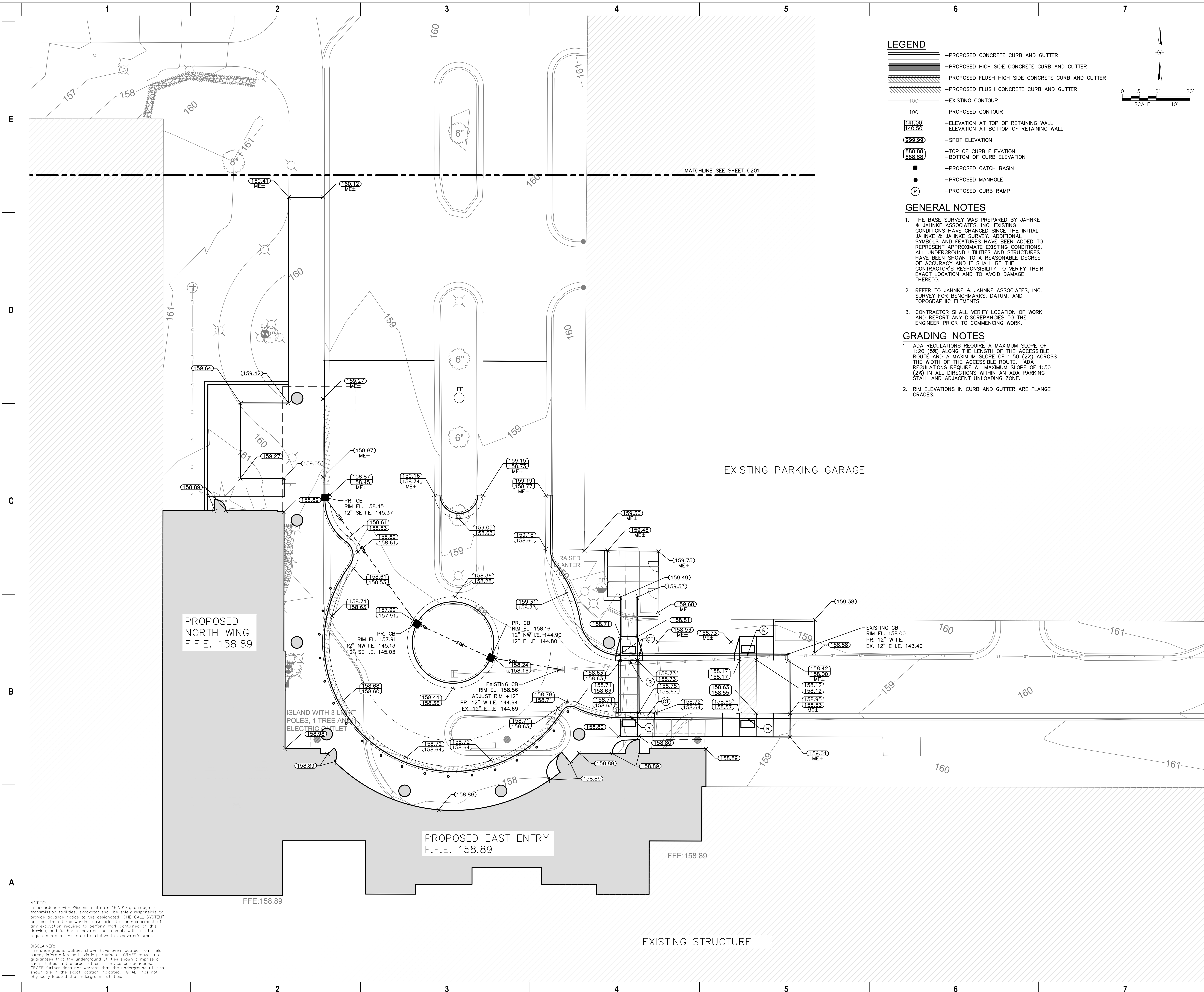
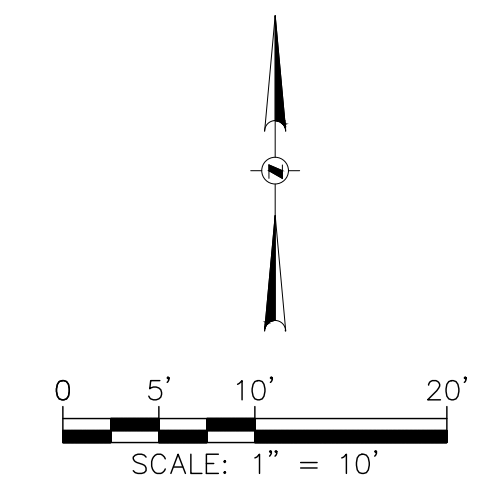

NOTICE:  
In accordance with Wisconsin statute 182.0175, damage to transmission facilities, excavator shall be solely responsible to provide advance notice to the designated "ONE CALL SYSTEM" not less than three working days prior to commencement of any excavation required to perform work contained on this drawing, and further, excavator shall comply with all other requirements of this statute relative to excavator's work.

DISCLAIMER:  
The underground utilities shown have been located from field survey information and existing drawings. GRAEF makes no guarantees that the underground utilities shown comprise all such utilities in the area, either in service or abandoned. GRAEF further does not warrant that the underground utilities shown are in the exact location indicated. GRAEF has not physically located the underground utilities.

X:\ML\2018\20180420\CAD\Site\dwg\00C\_00\_C300\_Grading\_420 12/19/2018 4:49 PM