

ISSUED FOR MUNICIPAL REVIEW

ENTERPRISE MOBILITY - PARKING LOT REHAB

1610 LINCOLN AVE
WAUKESHA, WISCONSIN

CALL OR CLICK 3 WORKING DAYS BEFORE YOU DIG

Help Us...
Help You...
Protect
Your Facilities!



CONTACTS

SITE CONTACT:
ENTERPRISE MOBILITY
S17 W22650 LINCOLN AVENUE
WAUKESHA, WISCONSIN
CONTACT: BEN TENNIES
PHONE: 262-544-8300 X248
EMAIL: BEN.H.TENNIES@EHI.COM

ENGINEER/AGENT:
ENDPOINT SOLUTIONS CORP.
6871 S. LOVERS LANE
FRANKLIN, WI 53132
CONTACT: JASON HEINONEN, P.E.
PHONE: 414-858-1920
EMAIL: JASON@ENDPOINTCORPORATION.COM

DRAWING SHEET INDEX

- C5 COVER SHEET
- C1 PRE-CONSTRUCTION CONDITIONS
- C2 DEMOLITION PLAN
- C3 PROPOSED SITE PLAN
- C4 PROPOSED GRADING AND EROSION CONTROL PLAN
- C5 GENERAL CONSTRUCTION NOTES
- C6 EROSION CONTROL DETAILS

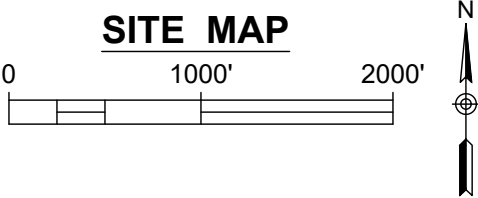
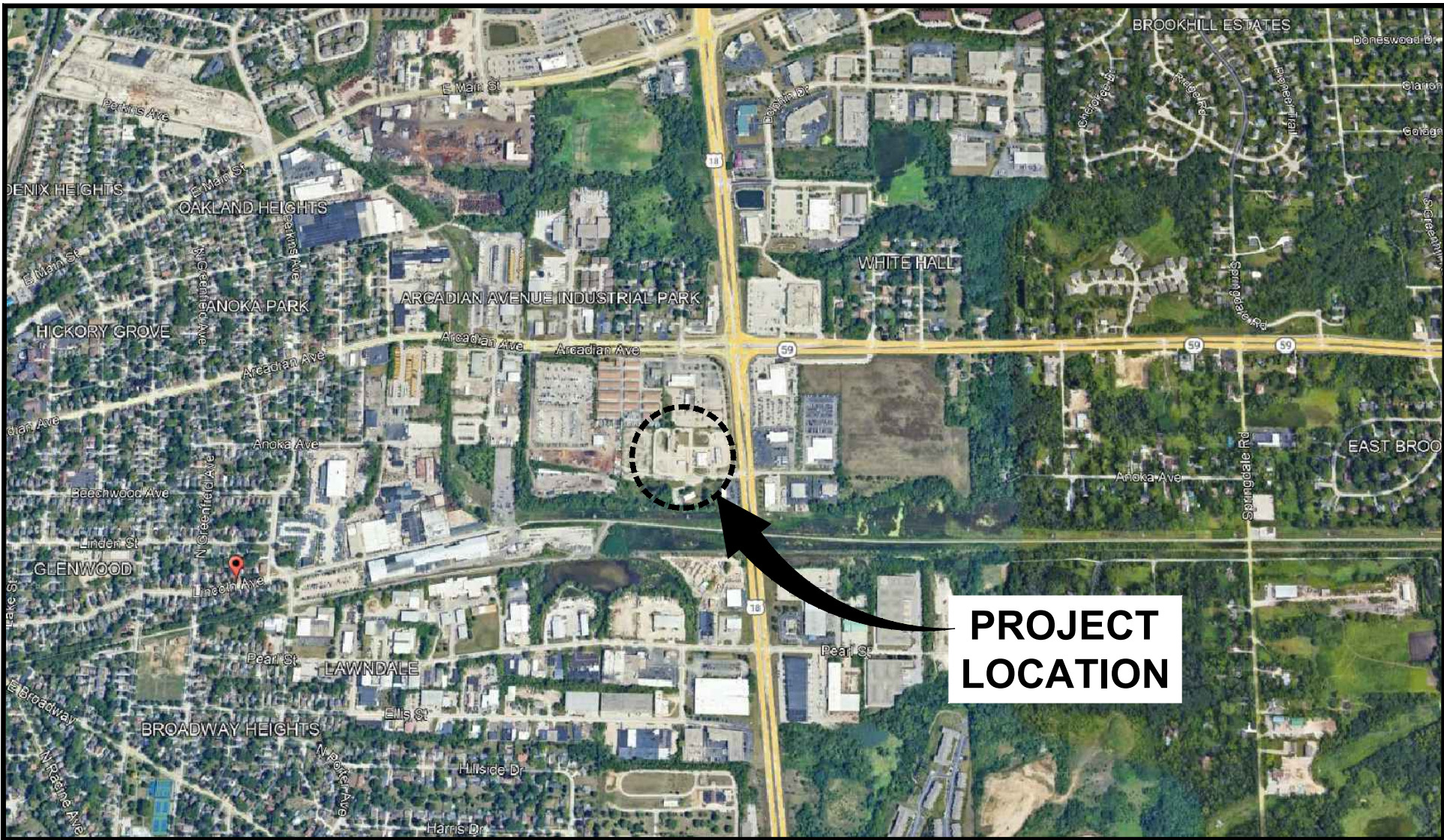

DATE ISSUED
JULY 29, 2024

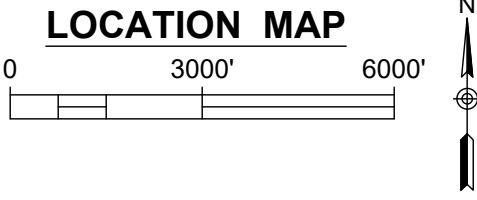
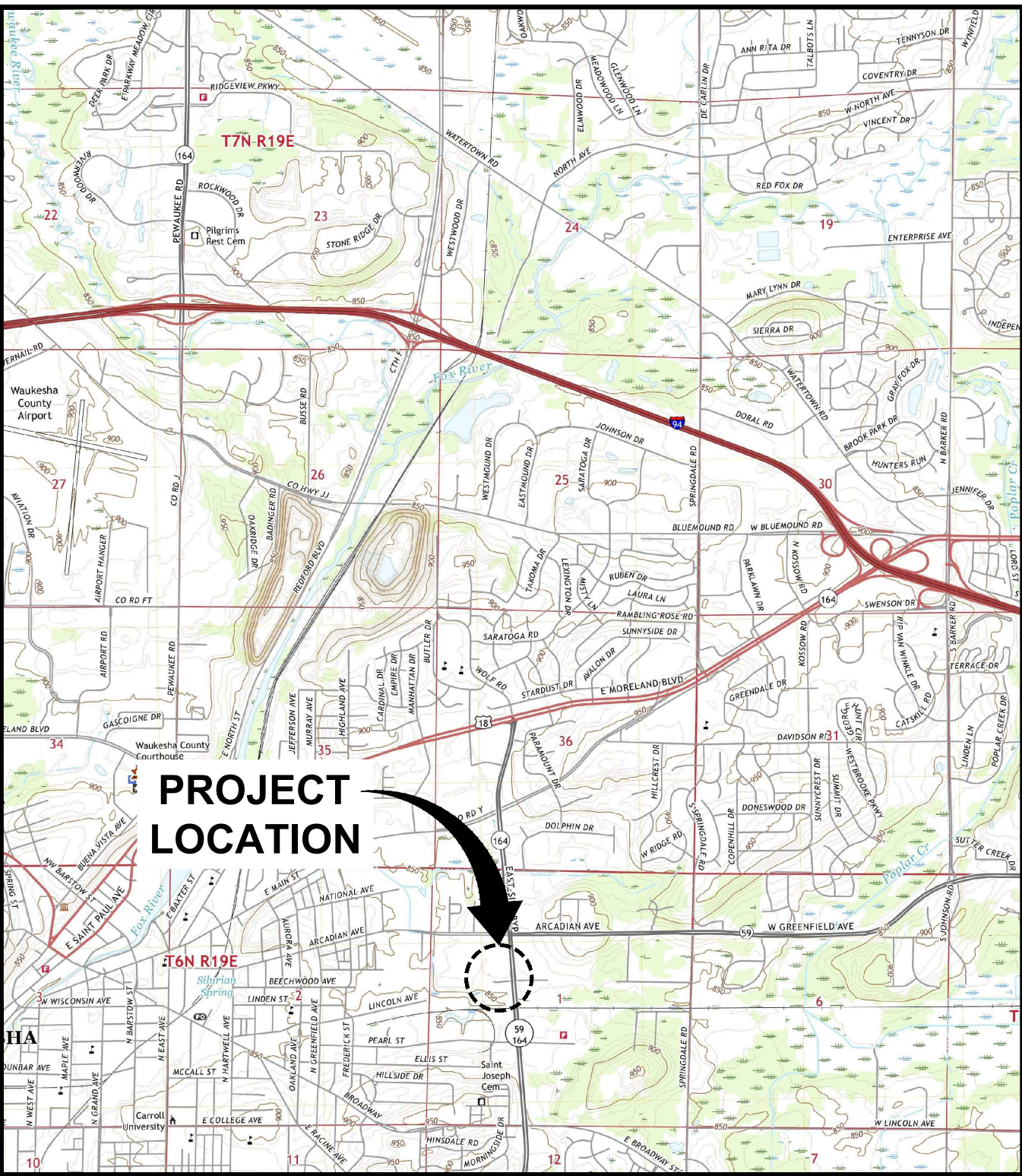

ALL SITE IMPROVEMENTS AND CONSTRUCTION SHOWN ON THE PLANS SHALL CONFORM TO THE CURRENT CITY OF WAUKESHA DESIGN AND CONSTRUCTION MANUAL. WHERE THE PLANS DO NOT COMPLY, IT SHALL BE THE SOLE RESPONSIBILITY AND EXPENSE OF THE DEVELOPER TO MAKE REVISIONS TO THE PLANS AND/OR CONSTRUCTED INFRASTRUCTURE TO COMPLY.



REVISION LOG

| REVISION | ISSUE DATE | REVISED SHEETS | ISSUED FOR |
|----------|------------|----------------|------------|
| | | | |
| | | | |
| | | | |
| | | | |



IMAGES: T:\Template Forms\CADD\Logos\Endpoint Solutions Hi-Res.jpg; P:\Enterprise Mobility-1065\Survey\PixExport\EnterpriseNadir-orthomosaic.jpg; T:\Template Forms\CADD\Logos\Endpoint Solutions Hi-Res.jpg; P:\Enterprise Mobility-1065\Survey\PixExport\EnterpriseNadir-orthomosaic.jpg; XREFS: \\1065-001-001_SURVEY\BASE.dwg

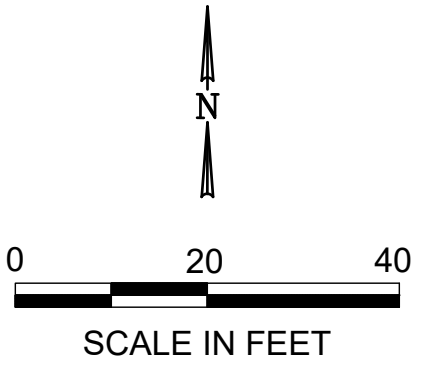
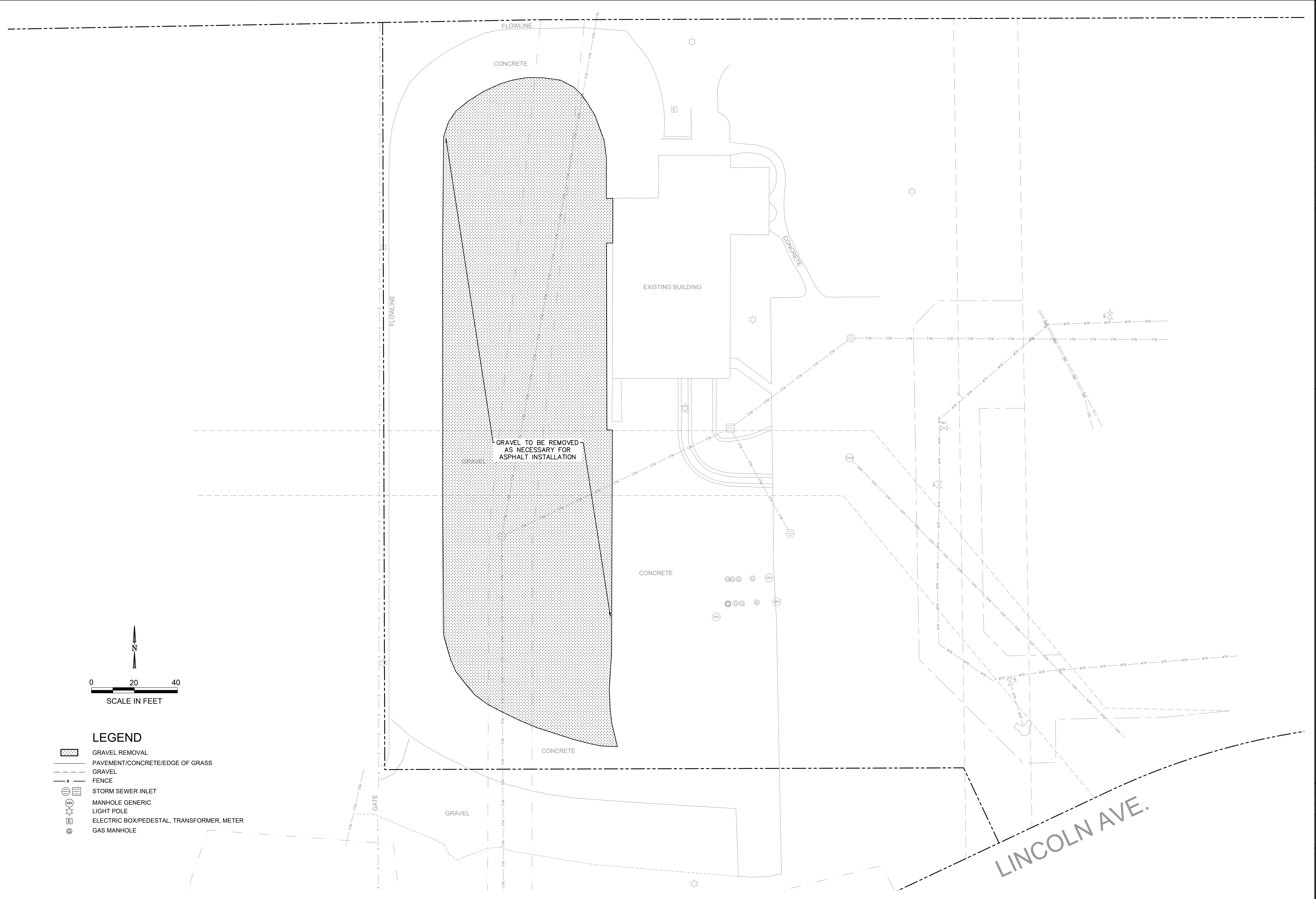

LEGEND

- GRAVEL REMOVAL
- PAVEMENT/CONCRETE/EDGE OF GRASS
- GRAVEL
- FENCE
- STORM SEWER INLET
- MANHOLE GENERIC
- LIGHT POLE
- ELECTRIC BOX/PEDESTAL, TRANSFORMER, METER
- GAS MANHOLE

| REV# | DATE |
|------|------|
| 6 | |
| 5 | |
| 4 | |
| 3 | |
| 2 | |
| 1 | |
| 0 | |

Endpoint Solutions
 6871 S. LOVERS LANE
 FRANKLIN, WI 53132
 PHONE: (414) 427-1200

DEMOLITION PLAN
 ENTERPRISE MOBILITY
 1610 LINCOLN AVE
 WAUKESHA, WI

DRAWN BY: JRT DATE:
 CHECKED BY: JAH 7/25/2024
 APPROVED BY: JAH

PROJECT NO.
 1065-001-001

SHEET NO.
C2

IMAGES: T:\Template Forms\CADD\Logos\Endpoint Solutions HI-Res.jpg; P:\Enterprise Mobility-1065\Survey\FixExport\EnterpriseNaair-orthomosaic.jpg; T:\Template Forms\CADD\Logos\Endpoint Solutions HI-Res.jpg; P:\Enterprise Mobility-1065\Survey\FixExport\EnterpriseNaair-orthomosaic.jpg; T:\Template Forms\CADD\Logos\Endpoint Solutions HI-Res.jpg; P:\Enterprise Mobility-1065\Survey\FixExport\EnterpriseNaair-orthomosaic.jpg



LANDSCAPE CALCULATION:
 TOTAL PARKING LOT AREA = 30,620 SF
 LANDSCAPED ISLAND AREA = 1,724 SF (5.6%)

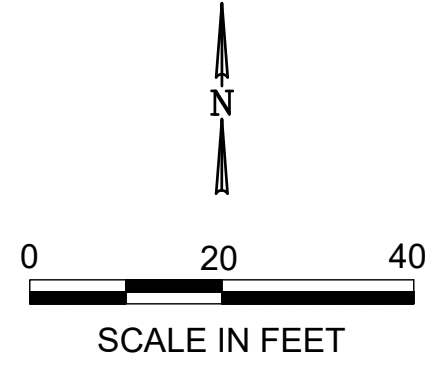

LEGEND

- PROPOSED ASPHALT PAVEMENT/CONCRETE/EDGE OF GRASS
- GRAVEL
- FENCE
- STORM SEWER INLET
- MANHOLE GENERIC
- LIGHT POLE
- ELECTRIC BOX/PEDESTAL, TRANSFORMER, METER
- GAS MANHOLE

| REV. | DATE |
|------|------|
| 6 | |
| 5 | |
| 4 | |
| 3 | |
| 2 | |
| 1 | |
| 0 | |

Endpoint Solutions
 6871 S. LOVERS LANE
 FRANKLIN, WI 53132
 PHONE: (414) 427-1200

PROPOSED SITE PLAN
 ENTERPRISE MOBILITY
 1610 LINCOLN AVE
 WAUKESHA, WI

DRAWN BY: JRT DATE:
 CHECKED BY: JAH 7/25/2024
 APPROVED BY: JAH

PROJECT NO.
 1065-001-001

SHEET NO.
C3

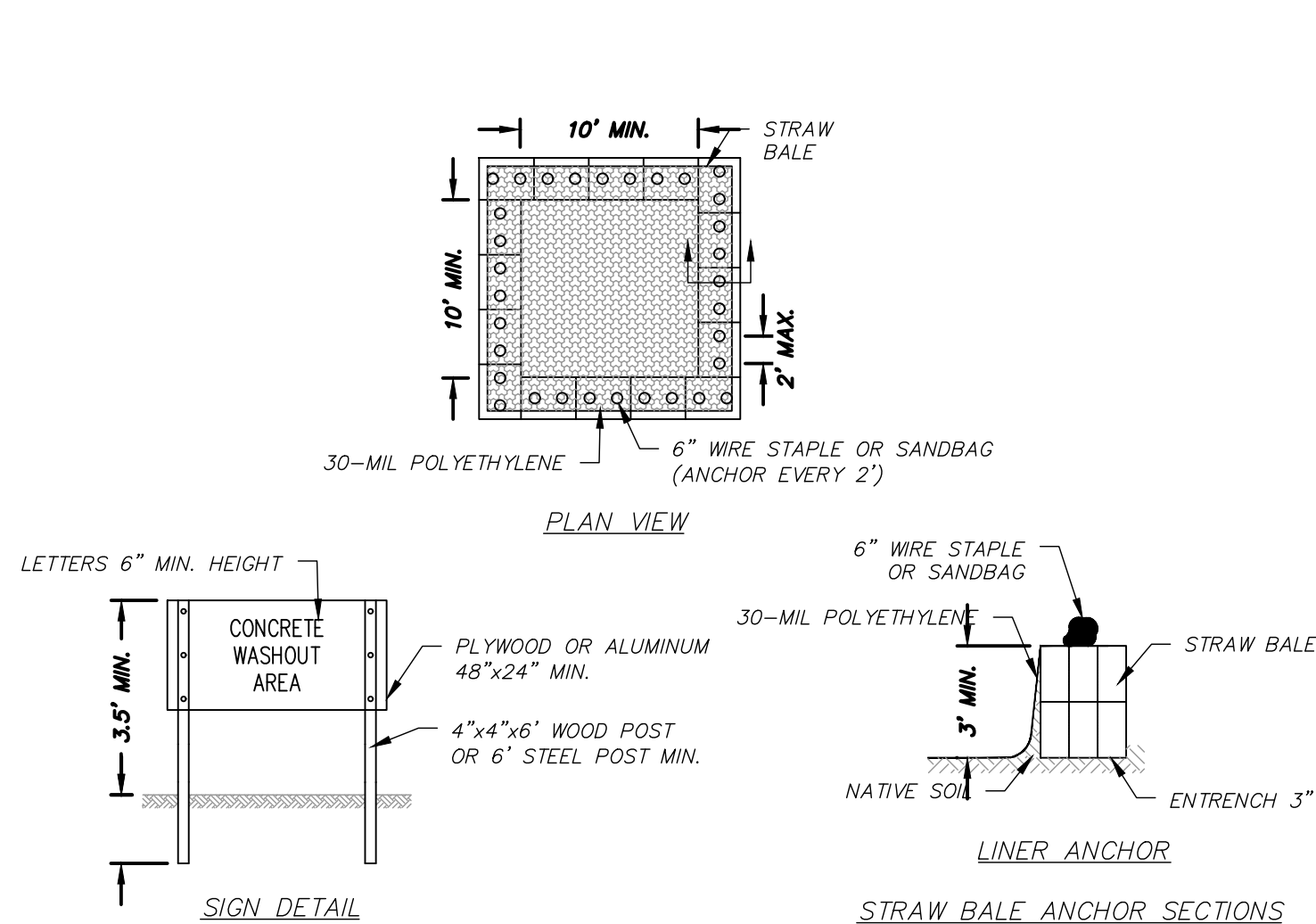

- NOTES:
1. MAINTAINING TEMPORARY CONCRETE WASHOUT FACILITIES SHALL INCLUDE REMOVING AND DISPOSING OF HARDENED CONCRETE AND/OR SLURRY AND RETURNING THE FACILITIES TO A FUNCTIONAL CONDITION.
 2. FACILITY SHALL BE CLEANED OR RECONSTRUCTED IN A NEW AREA ONCE WASHOUT BECOMES TWO-THIRDS FULL.
 3. EACH STRAW BALE IS TO BE STAKED IN PLACE USING (2) 2"x2"x4" WOODEN STAKES.

TEMPORARY CONCRETE WASHOUT FACILITY - STRAW BALE

NOT TO SCALE

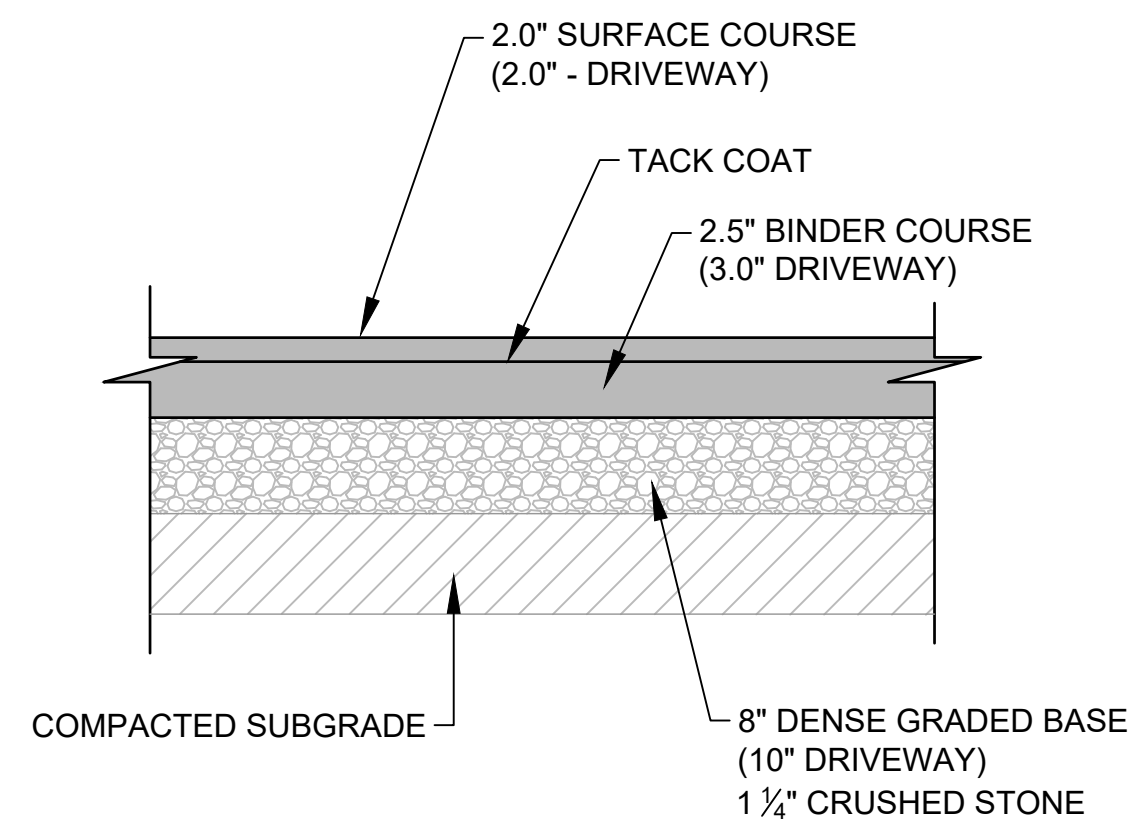

TYPICAL ASPHALT PAVEMENT

NOT TO SCALE

PAVEMENT NOTE:
COORDINATE FINAL PAVEMENT SECTIONS WITH PAVEMENT CONTRACTOR.

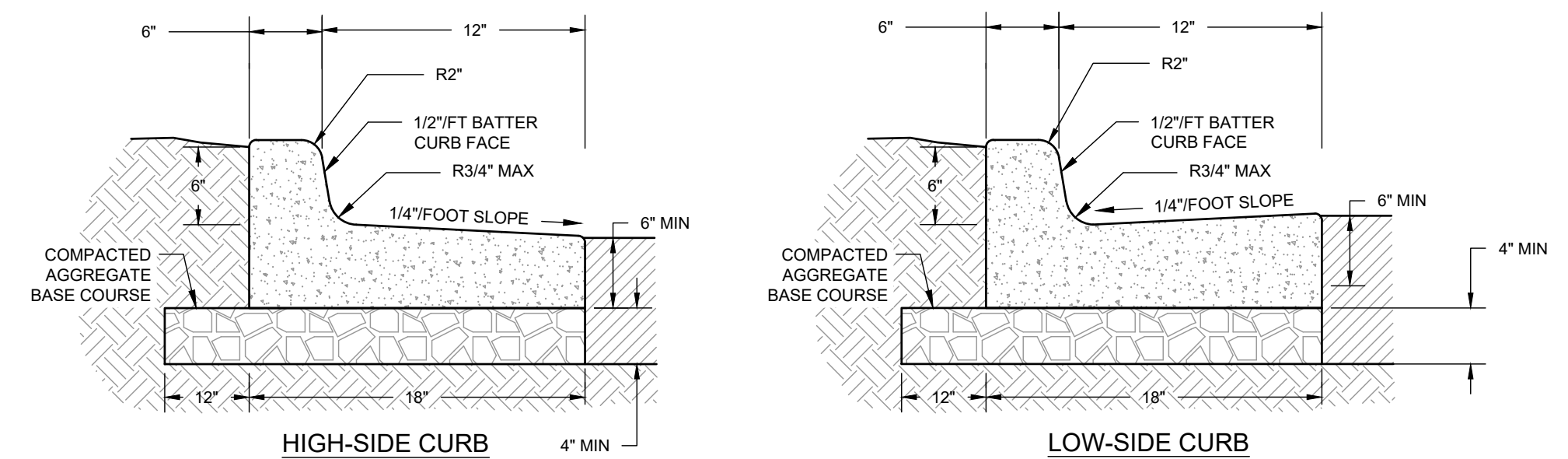

- NOTES:
- A) 3500 PSI CONCRETE SHALL BE USED IN CONSTRUCTION OF THE CURB & GUTTER.
 - B) THE CONTRACTOR IS RESPONSIBLE FOR DETERMINING THE SLOPE OF THE GUTTER PAN.
 - C) FOR DEPRESSED CURB HEAD SLOPE, USE THE SAME SLOPE AS ADJACENT SIDEWALK.
 - D) THE BOTTOM OF THE CURB AND GUTTER MAY BE CONSTRUCTED EITHER LEVEL OR PARALLEL TO THE SLOPE OF THE SUBGRADE OR BASE AGGREGATE PROVIDE MINIMUM 6" GUTTER THICKNESS MAINTAINED. TRANSVERSE CONTRACTION JOINTS SHALL BE CUT OR SAWED AT MAXIMUM 20 FOOT INTERVALS.
 - E) 1/2" PREFORMED EXPANSION JOINT FILLER SHALL BE PLACED TRANSVERSELY IN THE CURB ABUTTING EXISTING CURB AND SIDEWALK, WALLS OR BUILDINGS, AND AT INTERVALS NOT TO EXCEED 300 FEET, WITH PREFERRED LOCATIONS BEING AT RADIUS POINTS OR ANGLE POINTS.

18-IN. CONCRETE CURB & GUTTER

NOT TO SCALE

- NOTES:
1. CONSTRUCT IN ACCORDANCE WITH WISDOT STANDARD SPECIFICATIONS.
 4. CONCRETE SHALL BE GRADE A AIR ENTRAINED IN ACCORDANCE WITH WISDOT SECTION 501.
 5. FINISH, CURE, AND PROTECT CURBING IN ACCORDANCE WITH WISDOT SECTION 601.
 6. FINISHED CONCRETE SHALL BE COVERED WITH A LIQUID CURING COMPOUND CONFORMING TO AASHTO M 148, TYPE 2, IN ACCORDANCE WITH WISDOT SECTION 415.
 7. AGGREGATE BASE COURSE SHALL BE IN ACCORDANCE WITH WISDOT SECTION 305.

GENERAL GRADING NOTES

1. THE PROPOSED IMPROVEMENTS SHALL BE CONSTRUCTED ACCORDING TO THE D.O.T. STANDARD SPECIFICATIONS, LOCAL ORDINANCES AND SPECIFICATIONS, AND RECOMMENDATIONS IN THE GEOTECHNICAL REPORT.
2. THE CONTRACTOR SHALL ASSUME SOLE RESPONSIBILITY FOR THE COMPUTATIONS OF ALL GRADING AND FOR ACTUAL LAND BALANCE, INCLUDING UTILITY TRENCH SPOIL. THE CONTRACTOR SHALL IMPORT OR EXPORT MATERIAL AS NECESSARY TO COMPLETE THE PROJECT.
3. GRADING SHALL CONSIST OF CLEARING AND GRUBBING EXISTING VEGETATION, STRIPPING TOPSOIL, REMOVAL OF EXISTING PAVEMENT OR FOUNDATIONS, IMPORTING OR EXPORTING MATERIAL TO ACHIEVE AND ON-SITE EARTHWORK BALANCE, GRADING THE PROPOSED BUILDING PADS AND PAVEMENT AREAS, SCARIFYING AND FINAL COMPACTION OF THE PAVEMENT SUBGRADE, AND PLACEMENT OF TOPSOIL.
4. THE CONTRACTOR SHALL MAINTAIN SITE DRAINAGE THROUGHOUT CONSTRUCTION.
5. EROSION AND SEDIMENT CONTROL MEASURES ARE REQUIRED AS PART OF THIS PROJECT. CONSTRUCTION ACTIVITIES MUST COMPLY WITH ALL PROVISIONS OF LOCAL, STATE AND FEDERAL REGULATIONS AS WELL AS THE SITE SPECIFIC SWPPP (IF APPLICABLE). ALL LAND DISTURBING ACTIVITIES MAY BE SUBJECT TO INSPECTION BY LOCAL AUTHORITIES AND THE WISCONSIN DEPARTMENT OF NATURAL RESOURCES.
6. CONTRACTOR SHALL MINIMIZE CLEARING AND DISTURBANCE TO THE ENVIRONMENT TO THE EXTENT POSSIBLE. CONTRACTOR RESPONSIBLE FOR RESTORATION OF ALL DISTURBED AREAS.
7. RUBBISH, TRASH, GARBAGE, LITTER OR OTHER SUCH MATERIALS SHALL BE DISPOSED INTO SEALED CONTAINERS. MATERIALS SHALL BE PREVENTED FROM LEAVING THE SITE THROUGH THE ACTION OF WIND OR STORM WATER DISCHARGE INTO DRAINAGE DITCHES OR WATERS OF THE STATE. THE CONTRACTOR SHALL BE SOLELY RESPONSIBLE FOR THE REMOVAL OF CONSTRUCTION WASTE IN ACCORDANCE WITH ALL APPLICABLE FEDERAL, STATE AND LOCAL REGULATIONS.
8. SILT FENCE AND OTHER EROSION CONTROL FACILITIES MUST BE INSTALLED PRIOR TO CONSTRUCTION OR ANY OTHER LAND DISTURBING ACTIVITY. THE CONTRACTOR SHALL BE RESPONSIBLE FOR REMOVING ALL EROSION CONTROL FACILITIES ONCE THE SITE HAS STABILIZED.
9. NO FILL SHALL BE PLACED ON A WET OR SOFT SUBGRADE. THE SUBGRADE SHALL BE PROOF-ROLLED AND INSPECTED BY THE GEOTECHNICAL ENGINEER BEFORE ANY MATERIAL IS PLACED.
10. ALL FILL SHALL BE CONSIDERED STRUCTURAL FILL AND SHALL BE PLACED IN ACCORDANCE WITH THE GEOTECHNICAL REPORT
11. BEFORE PROCEEDING WITH ANY UTILITY CONSTRUCTION, THE CONTRACTOR SHALL EXCAVATE EACH EXISTING LATERAL OR POINT OF CONNECTION AND VERIFY THE SIZE, LOCATION AND ELEVATION OF ALL UTILITIES.
12. TEMPORARY EROSION CONTROL MATTING SHALL BE PLACED ON ALL SLOPES THAT ARE STEEPER THAN 4:1.
13. ALL PROPOSED CONTOURS REPRESENT FINAL FINISHED GRADE ELEVATIONS.

GENERAL NOTES

1. THE BIDDER WILL BE SOLELY RESPONSIBLE FOR QUANTITIES AND ESTIMATE OF WORK REQUIRED AND SHALL STATE SUCH QUANTITIES IN THEIR BID.
2. THE CONTRACTOR SHALL INDEMNIFY THE OWNER, THE ENGINEER, AND THE MUNICIPALITY, THEIR AGENTS, ETC, FROM ALL LIABILITY INVOLVED WITH THE CONSTRUCTION OF THIS PROJECT.
3. SITE SAFETY IS THE RESPONSIBILITY OF THE CONTRACTOR.
4. SOIL CONDITIONS SHALL BE VERIFIED BY THE CONTRACTOR PRIOR TO COMMENCEMENT OF CONSTRUCTION. A GEOTECHNICAL REPORT IS AVAILABLE FROM THE OWNER. THE CONTRACTOR SHALL ABIDE BY THE RECOMMENDATIONS OF THE GEOTECHNICAL ENGINEER.
5. THE CONTRACTOR SHALL OBTAIN AND PAY FOR ALL PERMITS REQUIRED FOR EXECUTION OF THE WORK. THE CONTRACTOR SHALL CONDUCT THEIR WORK ACCORDING TO THE REQUIREMENTS OF THE PERMITS.
6. THE CONTRACTOR IS RESPONSIBLE FOR EXAMINING ALL SITE CONDITIONS PRIOR TO COMMENCEMENT OF CONSTRUCTION AND SHALL COMPARE FIELD CONDITIONS WITH DRAWINGS.
7. CONTRACTOR SHALL PROTECT ADJACENT PROPERTIES DURING CONSTRUCTION. ANY PROPERTY (PRIVATE OR PUBLIC) WHICH ARE DAMAGED DURING CONSTRUCTION MUST BE RESTORED TO ORIGINAL CONDITIONS BY THE CONTRACTOR. THE COST OF THE RESTORATION IS CONSIDERED INCIDENTAL, AND SHOULD BE INCLUDED IN THE BID PRICES.
8. THE CONTRACTOR IS RESPONSIBLE FOR FIELD VERIFYING ALL UTILITY INFORMATION SHOWN ON THE PLANS PRIOR TO THE START OF CONSTRUCTION. THE CONTRACTOR SHALL CALL DIGGER'S HOTLINE TO REQUEST FIELD STAKING OF EXISTING UTILITIES AND NOTIFY THE UTILITIES OF THE PROJECT COMPONENTS.
9. CONTRACTOR SHALL ENSURE ALL MUD AND DEBRIS IS NOT DEPOSITED ONTO THE ADJACENT ROADWAYS PER THE REQUIREMENT OF THE AGENCY HAVING JURISDICTION ON THE ROADWAYS.
10. SUBMITTALS:
 - A. SHOP DRAWINGS AND/OR MANUFACTURER'S PRODUCT DATA SUBMITTALS ARE REQUIRED ONLY IF THE PRODUCT OR METHOD OF CONSTRUCTION:
 - a. IS DIFFERENT FROM THAT SPECIFIED OR
 - b. IS PART OF THE WORK THAT WILL BE DEDICATED AS A PUBLIC UTILITY OR ROADWAY AT THE END OF THE PROJECT OR
 - c. IF REQUIRED BY THE MUNICIPAL ENGINEER.
 - B. FOR UTILITY OR ROAD WORK THAT WILL BE DEDICATED TO A MUNICIPALITY, CONTRACTOR MUST MAKE SUBMITTALS TO THE MUNICIPALITY AS WELL AS ENGINEER.

PAVING

1. THE PROPOSED IMPROVEMENTS SHALL BE CONSTRUCTED ACCORDING TO THE WISCONSIN D.O.T. STANDARD SPECIFICATIONS FOR HIGHWAY AND STRUCTURE CONSTRUCTION, LATEST EDITION, AND THE LOCAL ORDINANCES AND SPECIFICATIONS, AND THE GEOTECHNICAL REPORT (IF AVAILABLE).
2. PAVING SHALL CONSIST OF FINE GRADING PAVEMENT AREAS, INSTALLATION OF CRUSHED STONE BASE, CONCRETE AND/OR BITUMINOUS PAVEMENT, PAVEMENT MARKING, AND CLEANUP. ALL MATERIALS SHALL BE PROVIDED BY THE CONTRACTOR.
3. AGGREGATES USED IN THE HMA SHALL BE IN ACCORDANCE WITH SUBSECTION 460.2.2.3 OF THE STANDARD SPECIFICATIONS.
4. CONCRETE CONSTRUCTION SHALL BE IN ACCORDANCE WITH THE FOLLOWING SECTIONS OF THE STANDARD SPECIFICATIONS: SECTION 415 FOR CONCRETE PAVEMENT AND SECTION 602 FOR CONCRETE SIDEWALKS.
5. PAVEMENT MARKINGS SHALL BE PAINT IN ACCORDANCE WITH SECTION 646 OF THE STANDARD SPECIFICATIONS. THE FOLLOWING ITEMS SHALL BE PAINTED WITH COLORS NOTED BELOW:

PARKING STALLS: WHITE
PEDESTRIAN CROSSWALKS: WHITE
ADA SYMBOLS: BLUE OR PER LOCAL CODE
EXTERIOR SIDEWALK CURBED, LIGHTPOLE BASES, AND GUARD POSTS: YELLOW

| REV. | DATE |
|------|------|
| 6 | |
| 5 | |
| 4 | |
| 3 | |
| 2 | |
| 1 | |
| 0 | |

Endpoint Solutions

6871 S. LOVERS LANE
FRANKLIN, WI 53132
PHONE: (414) 427-1200

GENERAL CONSTRUCTION NOTES

ENTERPRISE MOBILITY
1610 LINCOLN AVE
WAUKESHA, WI

DRAWN BY: JRT DATE:
CHECKED BY: JAH 7/25/2024
APPROVED BY: JAH

PROJECT NO.
1065-001-001

SHEET NO.
C5

8E10: Inlet Protection Type A, B, C and D

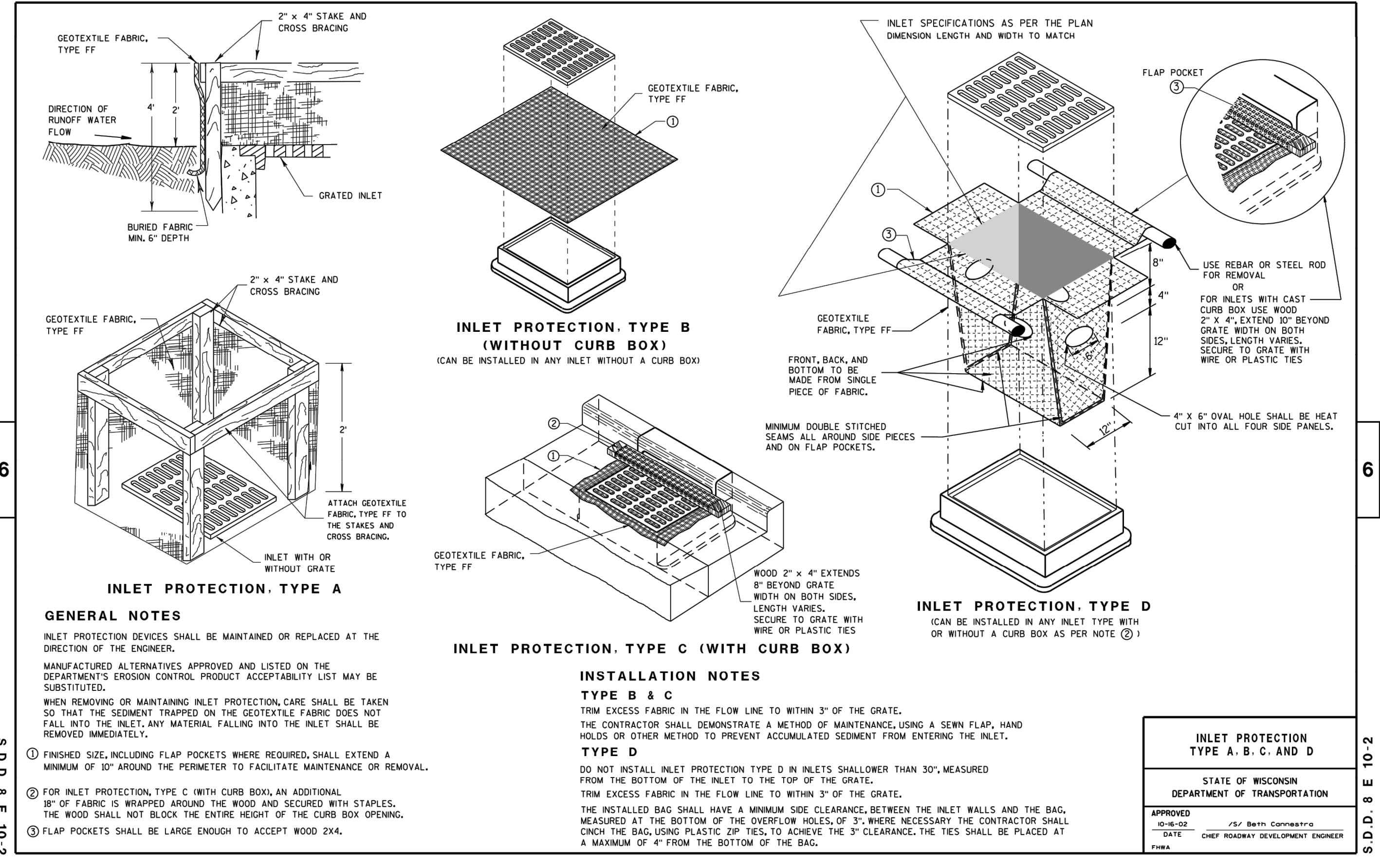

INLET PROTECTION
NOT TO SCALE

8E14: Tracking Pad

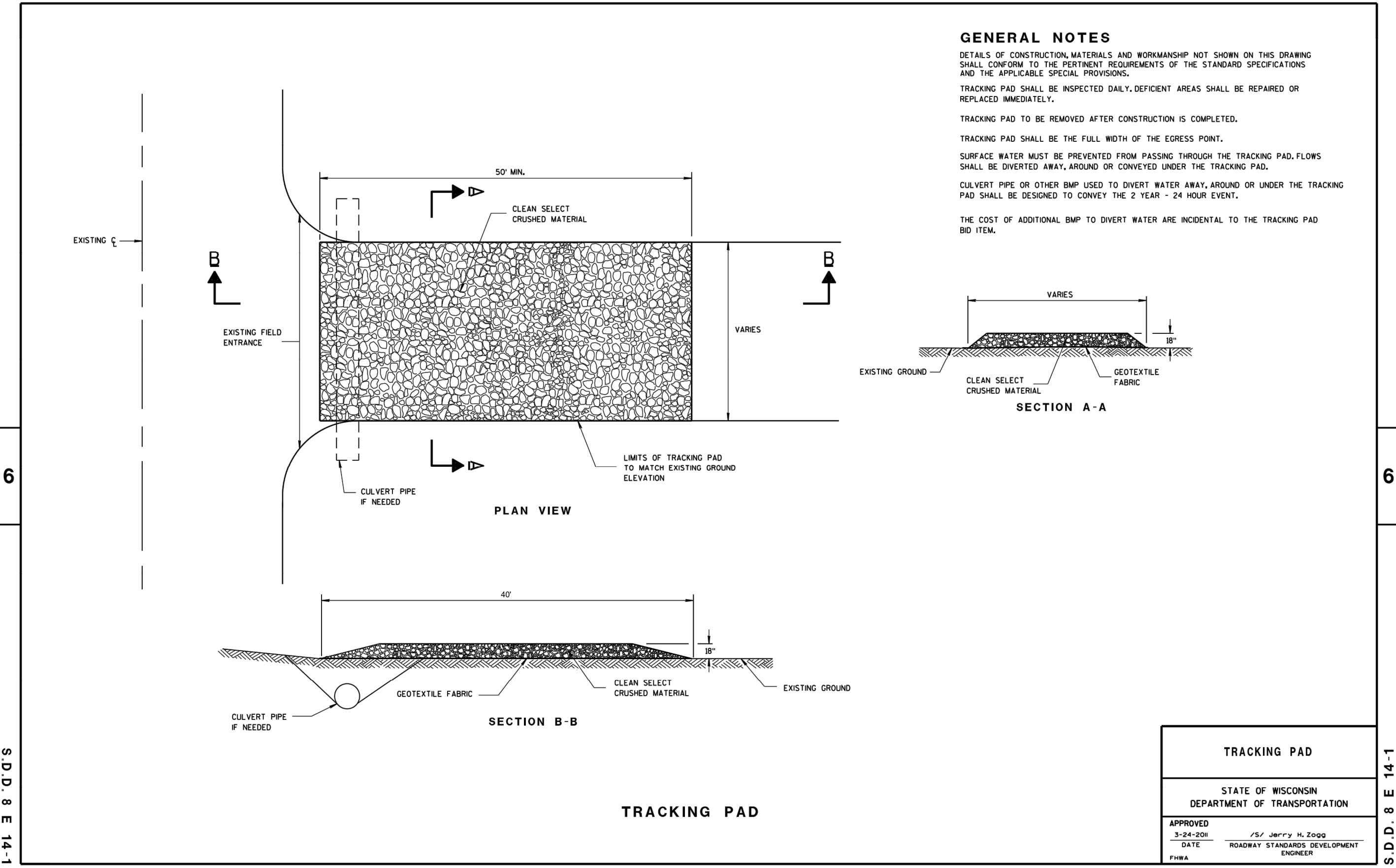

TRACKING PAD
NOT TO SCALE

8E9: Silt Fence

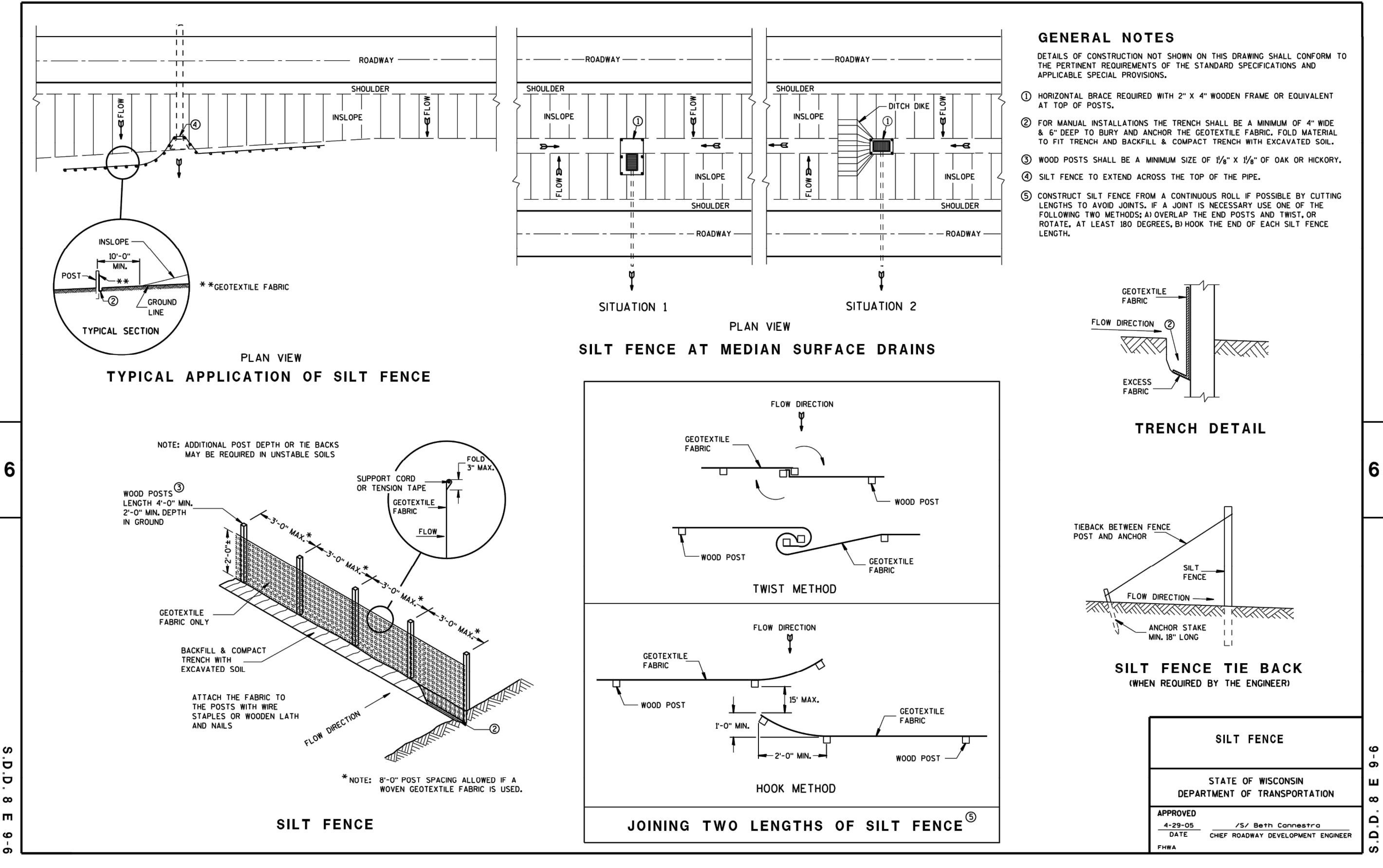

SILT FENCE
NOT TO SCALE

EROSION AND SEDIMENT CONTROL

- CONSTRUCT AND MAINTAIN EROSION CONTROL MEASURES IN ACCORDANCE WITH THE WISCONSIN DEPARTMENT OF NATURAL RESOURCES (WDNR) CHAPTERS NR 151 AND NR 216, WISCONSIN ADMINISTRATIVE CODE, AND APPROPRIATE WDNR TECHNICAL STANDARDS. EROSION AND SEDIMENT CONTROL PRODUCTS SHALL BE LISTED IN THE WISCONSIN DEPARTMENT OF TRANSPORTATION PRODUCT ACCEPTABILITY LIST (WisDOT PAL). THE CONTRACTOR IS RESPONSIBLE FOR OBTAINING COPIES OF THESE STATE REQUIREMENTS, TECHNICAL STANDARDS, AND WisDOT PAL.
- IMPLEMENT EROSION AND SEDIMENT CONTROL BEST MANAGEMENT PRACTICES (BMPs) PRIOR TO SOIL DISTURBING ACTIVITIES (E.G., CLEARING, GRUBBING, TOPSOIL STRIPING, EXCAVATION, MATERIAL STOCKPILING, ETC.). INSTALL EROSION CONTROL MEASURES AROUND STOCKPILE LOCATIONS.
- MINIMIZE DISTURBED AREA BY PHASING OR SEQUENCING CONSTRUCTION AND PRESERVING EXISTING VEGETATION WHERE POSSIBLE.
- DIVERT STORM WATER AWAY FROM DISTURBED OR EXPOSED AREAS WHEN POSSIBLE.
- PROTECT ADJACENT PROPERTIES WITH SEDIMENT BALE BARRIERS OR SILT FENCE UNTIL CONSTRUCTION IS COMPLETE IN ACCORDANCE WITH WDNR TECHNICAL STANDARDS 1055 OR 1056, RESPECTIVELY.
- INSTALL A GRAVEL TRACKING PAD IN ACCORDANCE WITH WDNR TECHNICAL STANDARD 1057. PAVED SURFACES ADJACENT TO CONSTRUCTION SITE VEHICLE ACCESS SHALL BE SWEEPED AND/OR SCRAPED PERIODICALLY TO REMOVE SOIL, DIRT, AND/OR DUST. ADJACENT ROADS ARE TO CLEANED IMMEDIATELY IF ANY SEDIMENT TRANSFER AND TRACKING OCCURS.
- PROTECT INLETS, CATCH BASINS, AND OTHER CONVEYANCE STRUCTURES WITH STRAW BALES, FILTER FABRIC, OR OTHER APPROPRIATE MEASURES IN ACCORDANCE WITH WDNR TECHNICAL STANDARD 1060.
- DURING DEWATERING ACTIVITIES, UTILIZE A COMPARTMENTED CONTAINER, SETTLING BASIN, FILTER, OR OTHER APPROPRIATE BEST MANAGEMENT PRACTICE FOR TREATING SEDIMENT-LADEN WATER PRIOR TO DISCHARGE OFF-SITE IN ACCORDANCE WITH WDNR TECHNICAL STANDARD 1061.
- INSPECT THE SITE REGULARLY AND PROPERLY MAINTAIN BMPs, ESPECIALLY AFTER RAINSTORMS. AT MINIMUM, INSPECTIONS OF CONSTRUCTION BMPs ARE REQUIRED AT LEAST ONCE EVERY SEVEN DAYS AND WITHIN 24 HOURS AFTER A PRECIPITATION EVENT OF 0.5 INCH OR MORE.
- BMPs MUST BE REPAIRED OR REPLACED WITHIN 24 HOURS OF INSPECTION OR NOTIFICATION OF A PROBLEM.
- KEEP THE CONSTRUCTION SITE CLEAN BY PUTTING TRASH IN TRASH CANS, KEEPING STORAGE BINS COVERED, AND PREVENTING OR REMOVING EXCESS SEDIMENT ON ROADS AND OTHER IMPERVIOUS SURFACES.
- SITE RESTORATION AND STABILIZATION MUST BE COMPLETED WITHIN 7 DAYS OF INACTIVITY.

EROSION CONTROL NOTES

ENTERPRISE MOBILITY
1610 LINCOLN AVE
WAUKESHA, WI

DRAWN BY: JRT DATE:
CHECKED BY: JAH 7/25/2024
APPROVED BY: JAH

PROJECT NO.
1065-001-001

SHEET NO.

C6