



www.walbecgroup.com  
(920) 757-7559

W6380 Design Drive  
Greenville, WI 54942 (920) 757-7559  
www.walbecgroup.com

Project:

**Prairie Philip Property  
2015 Pewaukee Road**

**Location:  
Waukesha, Wisconsin**

**STORM WATER  
MANAGEMENT PLAN**

Preparer:

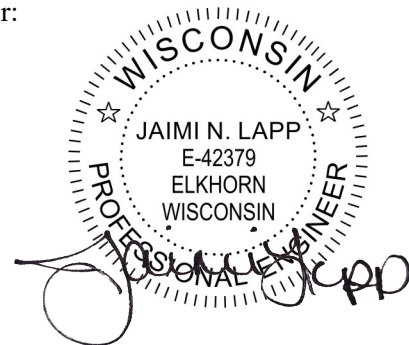

Project Number: 490493  
Last Revised: August 5, 2022

## Table of Contents

<b>1.0</b>	<b>INTRODUCTION .....</b>	<b>3</b>
	<b>PLANNING GOALS.....</b>	<b>3</b>
	<b>DESIGN SUMMARY.....</b>	<b>4</b>
<b>2.0</b>	<b>HYDROLOGIC CALCULATIONS .....</b>	<b>4</b>
	<i>Table 1: Design Rainfall Values .....</i>	<i>4</i>
<b>3.0</b>	<b>PRE-DEVELOPED CONDITIONS.....</b>	<b>4</b>
	<i>Table 2: Hydrologic Analysis of Pre-Developed Conditions.....</i>	<i>4</i>
<b>4.0</b>	<b>POST-DEVELOPMENT CONDITIONS.....</b>	<b>5</b>
	<i>Table 3: Hydrologic Analysis of Post-Development Conditions .....</i>	<i>5</i>
<b>5.0</b>	<b>ALLOWABLE PEAK RUNOFF RATES .....</b>	<b>5</b>
	<i>Table 4: Comparison of Pre- and Post-Development Flows.....</i>	<i>5</i>
<b>6.0</b>	<b>STORM WATER QUALITY CONTROL.....</b>	<b>5</b>
	<i>Table 5: Water Quality Modeling Results.....</i>	<i>6</i>
<b>7.0</b>	<b>INFILTRATION.....</b>	<b>6</b>
<b>8.0</b>	<b>STORMWATER MANAGEMENT MAINTENANCE PLAN .....</b>	<b>6</b>
<b>9.0</b>	<b>WISCONSIN DNR SOIL LOSS CALCULATIONS.....</b>	<b>6</b>
<b>APPENDICES</b>		
	Appendix 1     Location Map and USDA Web Soil Survey	
	Appendix 2     Drainage Area Map and HydroCAD Model Results	
	Appendix 3     WinSLAMM Input/Output	
	Appendix 4     Storm Water Maintenance Plan	
	Appendix 5     USLE Soil Loss Calculation, Erosion Control Plan and Storm Water Details	

## 1.0 INTRODUCTION

The Prairie Philip property at 2105 Pewaukee Road is located north of West Moreland Boulevard and south of Northview Road and the Waukesha County airport. The site was previously a residential site with just a small home and driveway. Recently, the site was disturbed and a long gravel driveway, a retaining wall and a large gravel parking area were constructed without rezoning or a City Site Plan Review, therefore erosion control and stormwater permits were not issued. The property owner was notified in October and December regarding the process that needed to be completed in order to be in compliance and Payne + Dolan was contracted to assist. A wet detention basin is planned for the property to comply with the storm water management requirements of the City of Waukesha and Wisconsin Department of Natural Resources (WDNR) at the time of approval.

The 5.089 acre study area is located within part of the NW ¼ of the NW 1/4, Section 35, T7N, R19E in the City of Waukesha, Waukesha County, Wisconsin. A location map for the site is located in **Appendix 1**.

Storm water management is required by the Wisconsin Department of Natural Resources (DNR) through Chapter NR 151 Runoff Management and the City of Waukesha's Chapter 32 Storm Water Management and Erosion Control because the proposed redevelopment causes a land disturbing activity of one acre or more. Therefore, redevelopment is required to implement the following controls:

- **Runoff Rate Control:** In the City of Waukesha, runoff rate control or detention is required whenever the proposed plan disturbs a total land surface of one acre or more. Per Chapter 32 “the calculated post-development peak storm water discharge rates shall not exceed the calculated pre-development discharge rates for the 1-year, 2-year, 10-year, and 100-year, 24-hour design storms”.
- **Sediment Control:** Per Chapter 32 “each storm water management plan shall meet the following post-development total suspended solids reduction targets, based on average annual rainfalls, as compared to no runoff management controls: (i.) For new land development and in-fill development, 80% reduction in total suspended solids load; (ii.) For redevelopment, 40% reduction of total suspended solids load from parking areas and roads.”
- **Infiltration:** Per Chapter 32 the site is assumed to be exempt from storm water infiltration requirements due to “the soils at the proposed bottom of an infiltration system have a measured infiltration rate of less than 0.6 inches per hour using a scientifically credible field testing method; and the Authority determines it would be impracticable to modify existing soil conditions based on soil profile evaluations extending five (5) feet below the proposed bottom of the infiltration system.” Borings have not been completed due to time constraints but based on the USDA web soil survey, the soils onsite are Hochheim Loam Hydrologic Soil Group Rating D which is classified by Table 2 in the WDNR Technical Standard Site Evaluation for Stormwater Infiltration as having a design infiltration rate without measurement as 0.24 inches/hour. The USDA Web Soil Survey is included in **Appendix 1**.

### Planning Goals

The stormwater planning goals include:

- Reduce pre-development peak flows to avoid off-site erosion during post-development storm water conveyance events; and
- Minimize sediment and other pollutants from leaving the site during and after construction; and

## Design Summary

To help accomplish the above goals, a stormwater conveyance system is proposed to be installed within the development. The site runoff will continue to follow the existing drainage patterns. The proposed site is required to maintain compliance with the following standards:

- Post-development peak storm water discharge rates shall not exceed the calculated pre-development discharge rates for the 1-year, 2-year, 10-year, and 100-year, 24-hour design storms in accordance with Chapter 32 design standards.
- The proposed site will control total suspended solids carried in runoff from the post-construction site. By design, the site shall reduce total suspended solids by 80% based on an average annual rainfall, as compared to no runoff management controls in accordance with WDNR design standards.
- BMPs will be constructed and maintained at the construction site to prevent pollutants from reaching waters of the state.

## 2.0 HYDROLOGIC CALCULATIONS

HydroCAD version 10.10-5a has been used to analyze storm water hydrologic characteristics for the site. HydroCAD uses the TR-55 methodology for determining peak discharge runoff rates. Curve numbers for the existing ground cover were selected for a “D” soil type in “good” condition using the maximum values specified in Chapter 32. Storm water modeling was conducted using the 1-year, 2-year, 10-year and 100-year storm events using the MSE3 rainfall distribution with rainfall depths per Chapter 32.

**Table 1: Design Rainfall Values**

Storm Recurrence Interval	24-hour Rainfall Depth
1-year	2.4 inches
2-year	2.7 inches
10-year	3.81 inches
100-year	6.18 inches

## 3.0 PRE-DEVELOPED CONDITIONS

The drainage study areas were determined using 1-foot topographic mapping generated from topographic field survey data developed for the project. A drainage area map is included in **Appendix 2**. The existing site is generally split with the west portion draining north off site before it drains east and the east portion draining south and east. As part of the Fox River watershed the entire site ultimately discharges to the east. The following table presents the results of the hydrological analysis for the existing conditions:

**Table 2: Hydrologic Analysis of Pre-Developed Conditions**

	Area (Ac)	Runoff Curve Number	Time of Conc. (min.)	Peak Flow Rate (cfs)			
				1-year	2-year	10-year	100-year
North (1S)	1.788	79	9.5	2.13	2.74	5.16	10.83
South and East (2S)	3.301	78	13.8	3.06	3.97	7.70	16.56
Total	5.089	---	---	4.97	6.43	12.38	26.48
Offsite (2aS)	0.941	78	29.4	0.58	0.75	1.47	3.18

Detailed hydrologic calculations for the study area are included in **Appendix 2**.

#### 4.0 POST-DEVELOPMENT CONDITIONS

The post-development conditions include a gravel driveway leading from the existing driveway east to a large gravel outdoor storage area.

The post-development drainage basins match those of the existing conditions. Proposed sub-basin 3S is undetained area that drains to the north as in the existing condition but flows over a grass filter strip prior to leaving the site. Proposed sub-basin 4S is area captured by the proposed swale and wet detention basin. The following table summarizes the results of the analysis of proposed conditions:

**Table 3: Hydrologic Analysis of Post-Development Conditions**

	Area (Ac)	Runoff Curve Number	Time of Conc. (min.)	Peak Flow Rate (cfs)			
				1-year	2-year	10-year	100-year
North (3S)	1.303	82	9.5	1.90	2.38	4.24	8.44
South and East (4S)	3.786	90	6.0	10.02	11.81	18.45	32.53
Total (w/o detention)	5.089	---	---	11.70	13.91	22.26	40.22
Offsite (4aS)	0.509	78	29.4	0.31	0.41	0.79	1.72
Offsite (4bS)	0.432	78	20.3	0.33	0.42	0.83	1.80
Detention Features				1-year	2-year	10-year	100-year
Wet Pond	Peak Inflow (cfs)			10.10	11.92	18.71	33.21
	Peak Outflow (cfs)			1.35	1.50	3.35	18.74
	High Water Level			893.39	893.65	894.45	895.14

Detailed hydrologic calculations are included in **Appendix 2**.

#### 5.0 ALLOWABLE PEAK RUNOFF RATES

Hydrologic analysis included in this report was performed using the HydroCAD hydrologic simulation computer model, version 10.10-5a by HydroCAD Software Solutions LLC. The discharges were generated using the SCS Dimensionless Unit Hydrograph Method for a 24-hour duration storm. Model parameters include drainage area, SCS runoff curve number, time of concentration and 24-hour precipitation with MSE3 NRCS rainfall distribution curve. A 6-minute minimum time of concentration was used for the east post-development area. The following table summarize the results of the analysis.

**Table 4: Comparison of Pre- and Post-Development Flows**

	1-year	2-year	10-year	100-year
Total Discharge (cfs)	Pre-developed Flows			
	5.23	6.78	13.14	28.25
	Post-developed Flows			
	3.25	3.92	6.45	27.98

#### 6.0 STORM WATER QUALITY CONTROL

The post-development site will utilize the wet pond and a grass filter strip north of the proposed gravel drive to achieve post-construction storm water quality control in accordance with the State of Wisconsin

requirements for suspended solids removal.

The requirement is 80% removal of the Total Suspended Solids (TSS) as compared to no controls. Water quality analysis included in this report was performed using the Source Loading and Management Model (WINSLAMM) computer model, version 10.4.1. WINSLAMM was adopted and calibrated by the Wisconsin Department of Natural Resources to better understand the relationships between sources of urban runoff pollutants and runoff quality. Detailed computations are provided in **Appendix 3**.

The water quality modeling results for the study area are as follows:

**Table 5: Water Quality Modeling Results**

Site	No Controls (lbs)	With Controls (lbs)	% Reduction
Post-developed Site	532.6	104.6	80.36%

## 7.0 INFILTRATION

The proposed development site is exempt from the WDNR infiltration requirements.

## 8.0 STORMWATER MANAGEMENT MAINTENANCE PLAN

The stormwater management maintenance provisions and inspection checklist are detailed in **Appendix 4**.

## 9.0 WISCONSIN DNR SOIL LOSS CALCULATIONS

The erosion control best management practices and construction sequence for the proposed development has been developed using the Wisconsin DNR Sediment Loss & Discharge Calculation Tool Version 2.0. See **Appendix 5**.

# Appendix 1

## Site Location Map and USDA Web Soil Survey



# Site Location Map

Located at 2105 Pewaukee Road Waukesha, WI 53188:

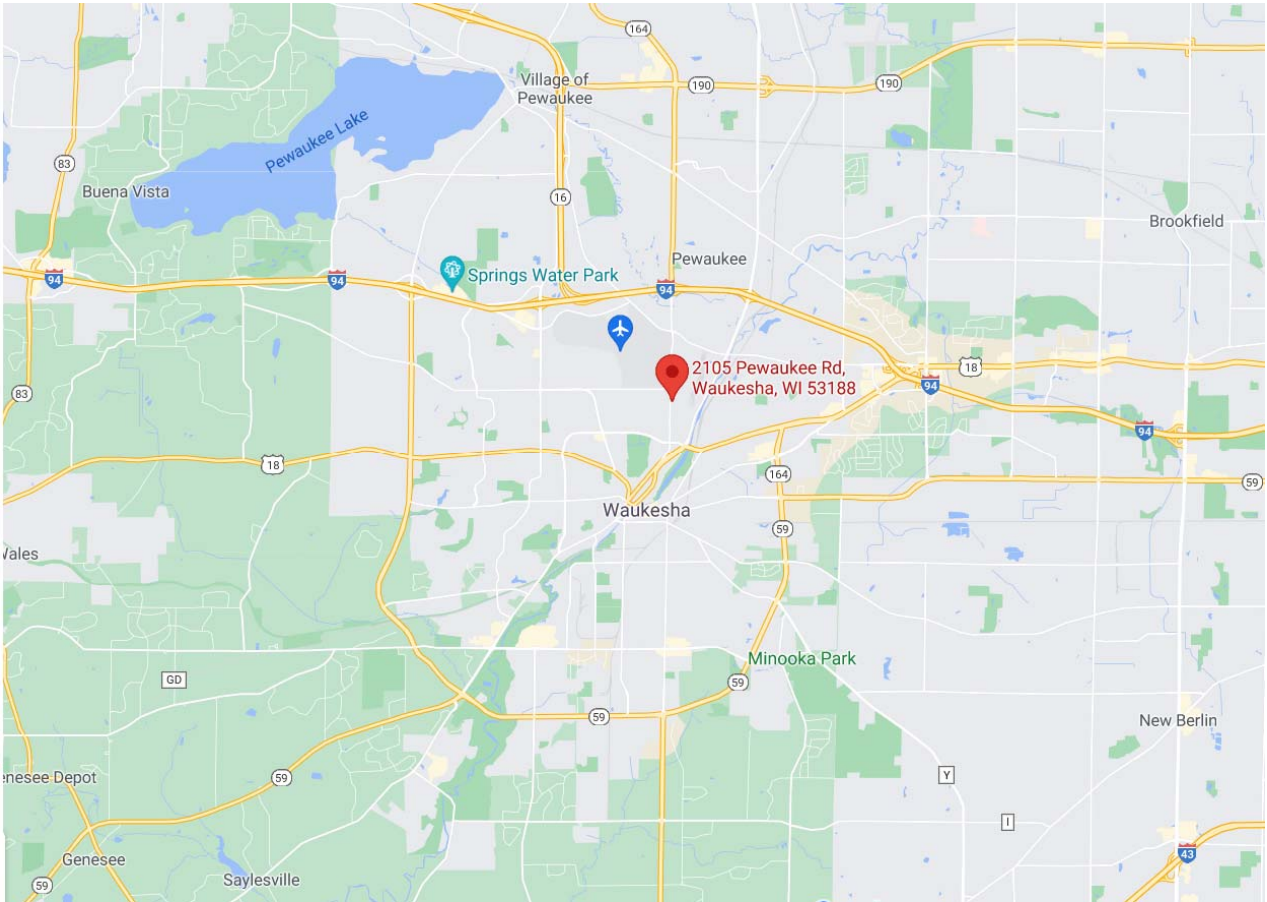
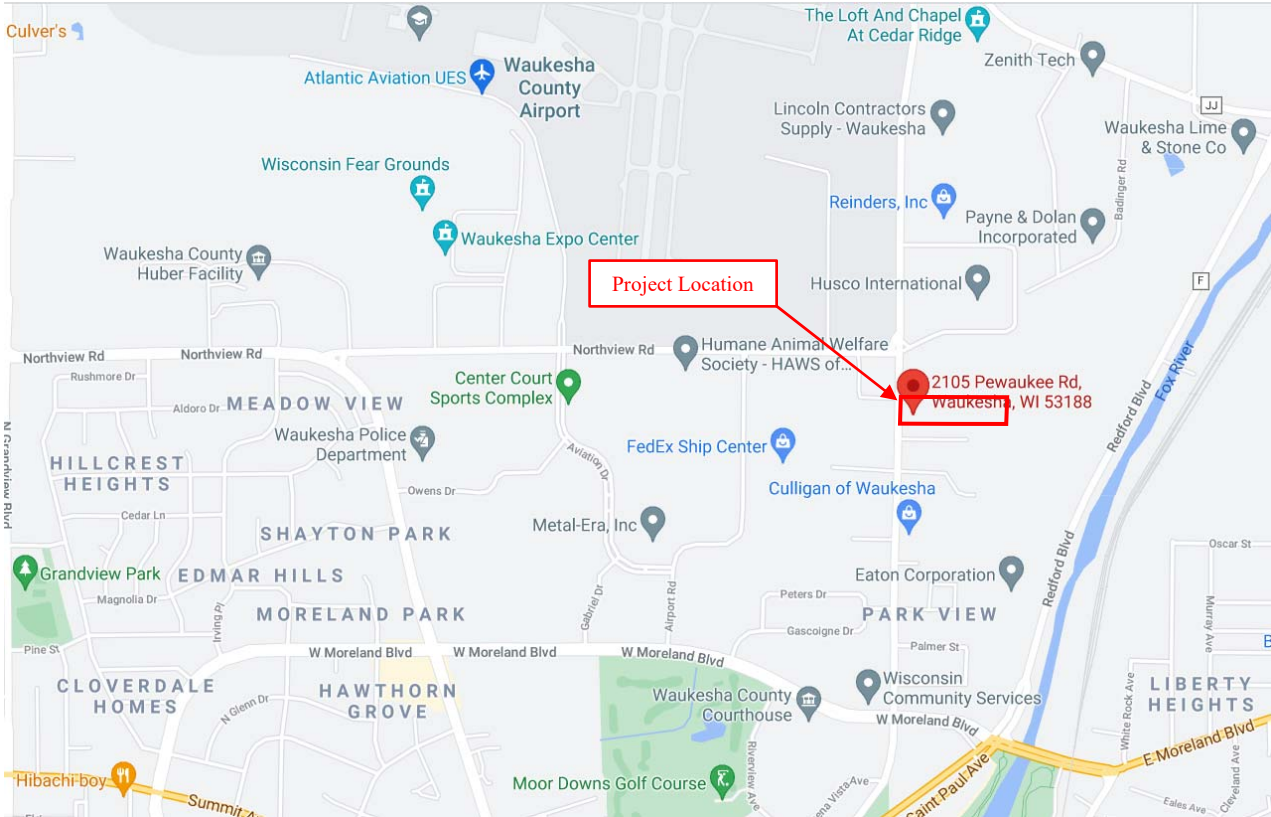



Hydrologic Soil Group—Milwaukee and Waukesha Counties, Wisconsin



Map Scale: 1:1,810 if printed on A landscape (11" x 8.5") sheet.

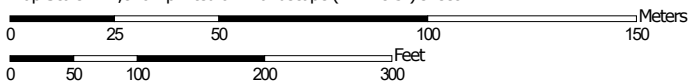

Map projection: Web Mercator Corner coordinates: WGS84 Edge tics: UTM Zone 16N WGS84



## MAP LEGEND

### Area of Interest (AOI)









 Area of Interest (AOI)

### Soils

#### Soil Rating Polygons

 A  
 A/D  
 B  
 B/D  
 C  
 C/D  
 D  
 Not rated or not available

#### Soil Rating Lines

 A  
 A/D  
 B  
 B/D  
 C  
 C/D  
 D  
 Not rated or not available

#### Soil Rating Points

 A  
 A/D  
 B  
 B/D

 C  
 C/D  
 D  
 Not rated or not available

### Water Features

 Streams and Canals

### Transportation

 Rails  
 Interstate Highways  
 US Routes  
 Major Roads  
 Local Roads

### Background

 Aerial Photography

## MAP INFORMATION

The soil surveys that comprise your AOI were mapped at 1:15,800.

**Warning:** Soil Map may not be valid at this scale.

Enlargement of maps beyond the scale of mapping can cause misunderstanding of the detail of mapping and accuracy of soil line placement. The maps do not show the small areas of contrasting soils that could have been shown at a more detailed scale.

Please rely on the bar scale on each map sheet for map measurements.

Source of Map: Natural Resources Conservation Service  
 Web Soil Survey URL:  
 Coordinate System: Web Mercator (EPSG:3857)

Maps from the Web Soil Survey are based on the Web Mercator projection, which preserves direction and shape but distorts distance and area. A projection that preserves area, such as the Albers equal-area conic projection, should be used if more accurate calculations of distance or area are required.

This product is generated from the USDA-NRCS certified data as of the version date(s) listed below.

Soil Survey Area: Milwaukee and Waukesha Counties, Wisconsin  
 Survey Area Data: Version 16, Jun 8, 2020

Soil map units are labeled (as space allows) for map scales 1:50,000 or larger.

Date(s) aerial images were photographed: Aug 1, 2019—Oct 12, 2019

The orthophoto or other base map on which the soil lines were compiled and digitized probably differs from the background imagery displayed on these maps. As a result, some minor shifting of map unit boundaries may be evident.

## Hydrologic Soil Group

Map unit symbol	Map unit name	Rating	Acres in AOI	Percent of AOI
HmB	Hochheim loam, 2 to 6 percent slopes	D	1.8	32.8%
HmB2	Hochheim loam, 2 to 6 percent slopes, eroded	D	0.3	5.3%
HmC2	Hochheim loam, 6 to 12 percent slopes, eroded	D	3.1	56.9%
HmD2	Hochheim loam, 12 to 20 percent slopes, eroded	D	0.2	2.9%
HoD3	Hochheim soils, 12 to 20 percent slopes, severely eroded	B	0.1	1.8%
ThB	Theresa silt loam, 2 to 6 percent slopes	C	0.0	0.2%
<b>Totals for Area of Interest</b>			<b>5.5</b>	<b>100.0%</b>

## Description

Hydrologic soil groups are based on estimates of runoff potential. Soils are assigned to one of four groups according to the rate of water infiltration when the soils are not protected by vegetation, are thoroughly wet, and receive precipitation from long-duration storms.

The soils in the United States are assigned to four groups (A, B, C, and D) and three dual classes (A/D, B/D, and C/D). The groups are defined as follows:

Group A. Soils having a high infiltration rate (low runoff potential) when thoroughly wet. These consist mainly of deep, well drained to excessively drained sands or gravelly sands. These soils have a high rate of water transmission.

Group B. Soils having a moderate infiltration rate when thoroughly wet. These consist chiefly of moderately deep or deep, moderately well drained or well drained soils that have moderately fine texture to moderately coarse texture. These soils have a moderate rate of water transmission.

Group C. Soils having a slow infiltration rate when thoroughly wet. These consist chiefly of soils having a layer that impedes the downward movement of water or soils of moderately fine texture or fine texture. These soils have a slow rate of water transmission.

Group D. Soils having a very slow infiltration rate (high runoff potential) when thoroughly wet. These consist chiefly of clays that have a high shrink-swell potential, soils that have a high water table, soils that have a claypan or clay layer at or near the surface, and soils that are shallow over nearly impervious material. These soils have a very slow rate of water transmission.

If a soil is assigned to a dual hydrologic group (A/D, B/D, or C/D), the first letter is for drained areas and the second is for undrained areas. Only the soils that in their natural condition are in group D are assigned to dual classes.

## Rating Options

*Aggregation Method:* Dominant Condition

*Component Percent Cutoff:* None Specified

*Tie-break Rule:* Higher

# Appendix 2

## Drainage Area Map and HydroCAD Model Results



### EXISTING HYDROLOGY (2015) ORIGINAL SITE

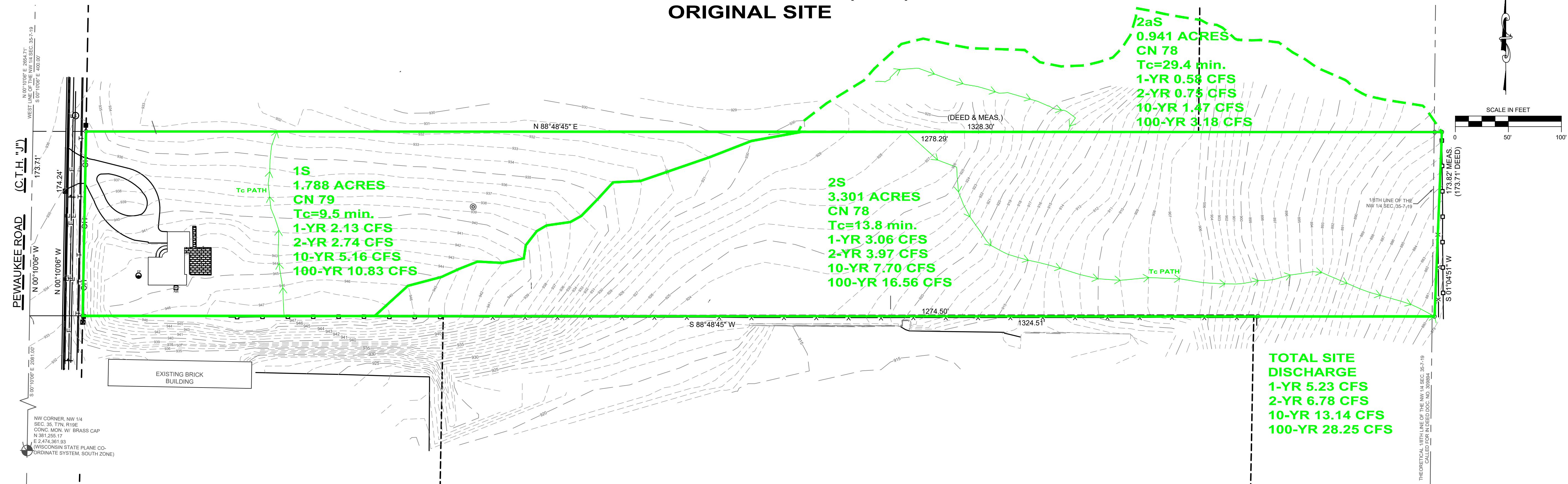

### PROPOSED HYDROLOGY CONSTRUCTION STARTED 2020

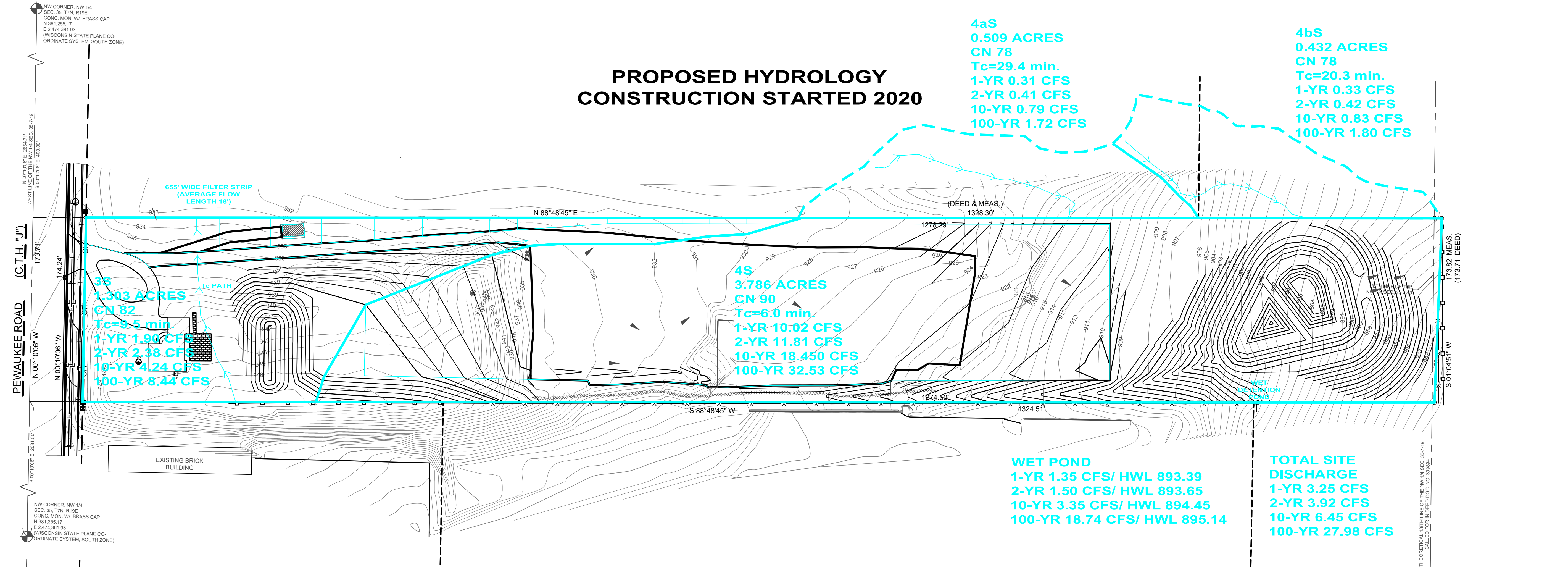

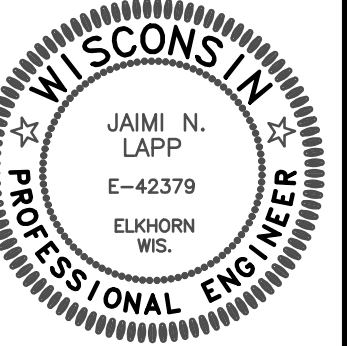
DATE	
REVISION DESCRIPTION	
NO.	
 A WALBECC COMPANY www.walbeccgroup.com (820) 787-7556	
PROJECT	OUTDOOR STORAGE YARD
CLIENT	PRAIRIE PHILIP LLC
ADDRESS	2105 PEWAUKEE ROAD
SCALE	1" = 50'
	
HYDROLOGY EXHIBIT	
COPYRIGHT NOTICE THESE DRAWINGS AS INSTRUMENTS OF SERVICE REMAIN THE PROPERTY OF PAYNE & DOLAN, INC. ANY CHANGES, PUBLICATION, OR UNAUTHORIZED USE IS PROHIBITED UNLESS EXPRESSLY AUTHORIZED BY PAYNE & DOLAN, INC.	
Drawing Scale:	1" = 50'
Drawn:	JNL
Checked:	08/05/2022
P&D Project No:	490493
Sheet No:	



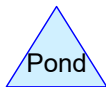
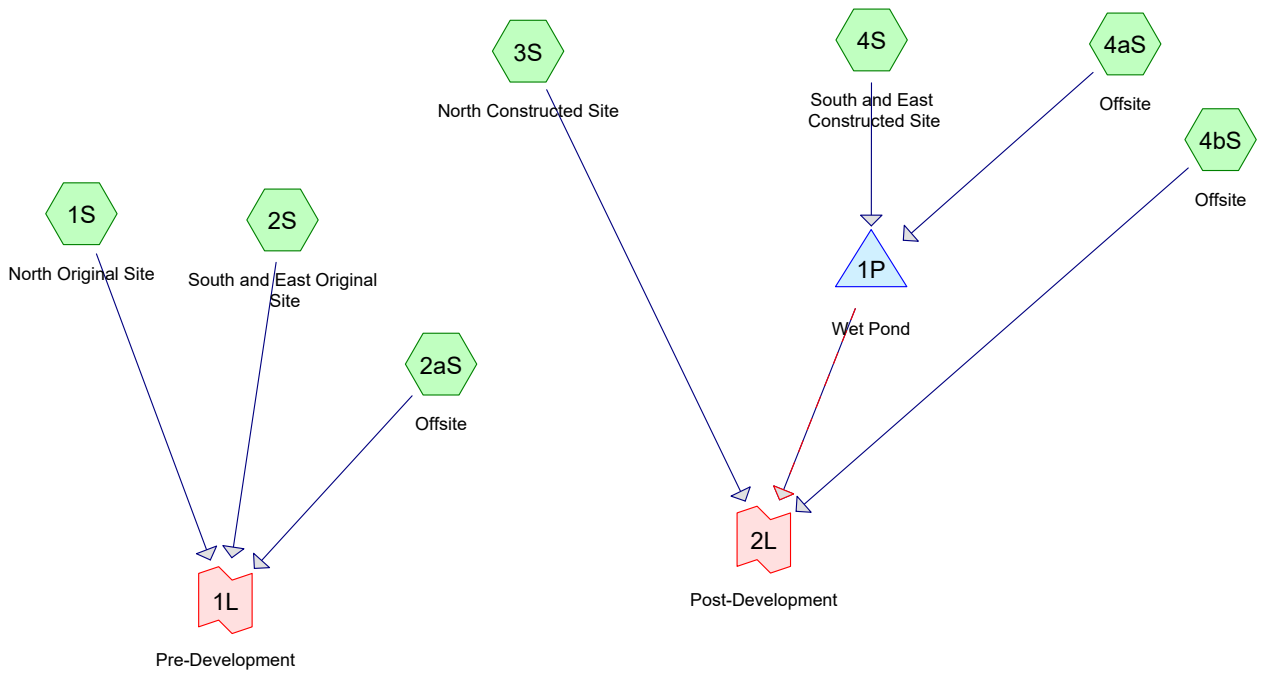

**Routing Diagram for 2022-08-05 Prairie Phillip**  
 Prepared by Construction Resources Management, Printed 8/5/2022  
 HydroCAD® 10.10-7a s/n 08699 © 2021 HydroCAD Software Solutions LLC



**Summary for Subcatchment 1S: North Original Site**

Runoff = 2.13 cfs @ 12.18 hrs, Volume= 0.115 af, Depth= 0.77"  
 Routed to Link 1L : Pre-Development

Runoff by SCS TR-20 method, UH=SCS, Weighted-CN, Time Span= 0.00-72.00 hrs, dt= 0.01 hrs  
 MSE 24-hr 3 1-Yr Rainfall=2.40"

Area (ac)	CN	Description
* 0.061	98	Paved asphalt drive, HSG D
* 0.017	98	Paved walks, HSG D
0.037	98	Roofs, HSG D
* 1.673	78	>75% Grass cover, Good, HSG D per ordinance
1.788	79	Weighted Average
1.673		93.57% Pervious Area
0.115		6.43% Impervious Area

Tc (min)	Length (feet)	Slope (ft/ft)	Velocity (ft/sec)	Capacity (cfs)	Description
8.9	100	0.0800	0.19		<b>Sheet Flow,</b> Grass: Dense n= 0.240 P2= 2.70"
0.6	75	0.0800	1.98		<b>Shallow Concentrated Flow,</b> Short Grass Pasture Kv= 7.0 fps
9.5	175	Total			

**Subcatchment 1S: North Original Site**

Hydrograph

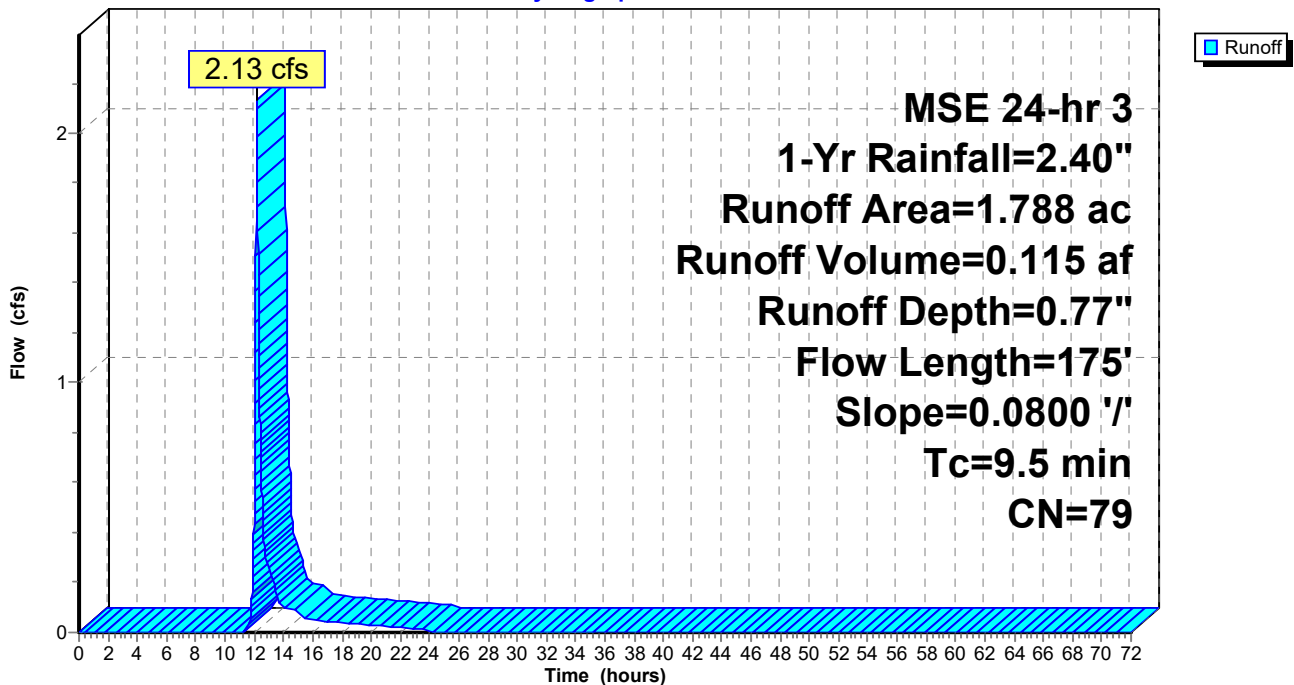

**Summary for Subcatchment 2aS: Offsite**

Runoff = 0.58 cfs @ 12.45 hrs, Volume= 0.057 af, Depth= 0.72"  
 Routed to Link 1L : Pre-Development

Runoff by SCS TR-20 method, UH=SCS, Weighted-CN, Time Span= 0.00-72.00 hrs, dt= 0.01 hrs  
 MSE 24-hr 3 1-Yr Rainfall=2.40"

Area (ac)	CN	Description
* 0.941	78	>75% Grass cover, Good, HSG D per ordinance
0.941		100.00% Pervious Area

Tc (min)	Length (feet)	Slope (ft/ft)	Velocity (ft/sec)	Capacity (cfs)	Description
29.4					Direct Entry,

**Subcatchment 2aS: Offsite**

Hydrograph

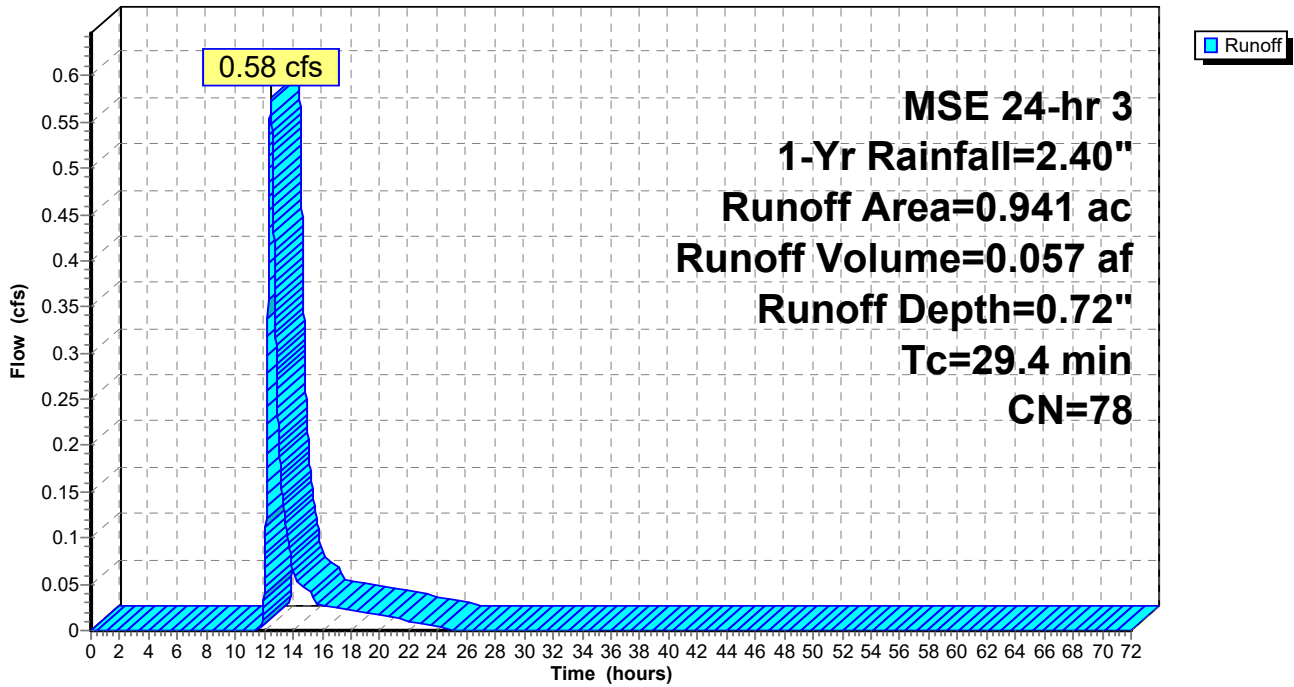

**Summary for Subcatchment 2S: South and East Original Site**

Runoff = 3.06 cfs @ 12.23 hrs, Volume= 0.199 af, Depth= 0.72"  
 Routed to Link 1L : Pre-Development

Runoff by SCS TR-20 method, UH=SCS, Weighted-CN, Time Span= 0.00-72.00 hrs, dt= 0.01 hrs  
 MSE 24-hr 3 1-Yr Rainfall=2.40"

Area (ac)	CN	Description
* 3.301	78	>75% Grass cover, Good, HSG D per ordinance
3.301		100.00% Pervious Area

Tc (min)	Length (feet)	Slope (ft/ft)	Velocity (ft/sec)	Capacity (cfs)	Description
10.0	100	0.0600	0.17		Sheet Flow, Grass: Dense n= 0.240 P2= 2.70"
3.8	475	0.0900	2.10		Shallow Concentrated Flow, Short Grass Pasture Kv= 7.0 fps
13.8	575	Total			

**Subcatchment 2S: South and East Original Site**

Hydrograph

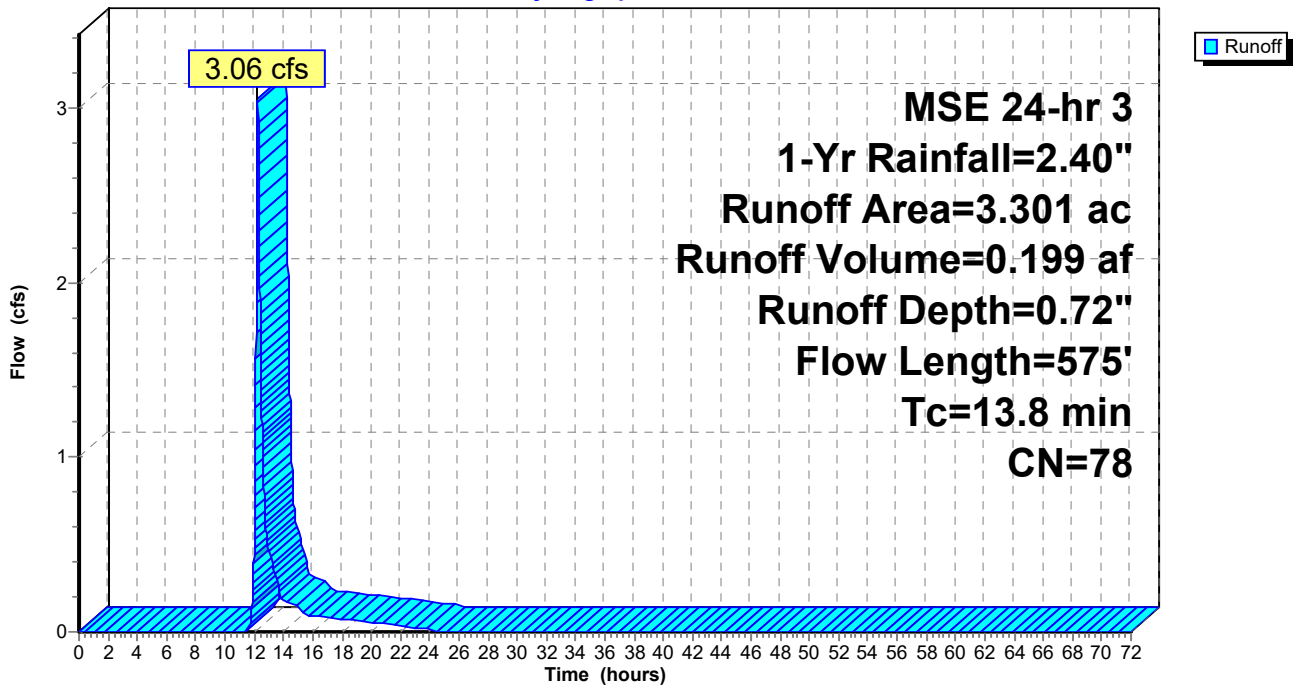

**Summary for Subcatchment 3S: North Constructed Site**

Runoff = 1.90 cfs @ 12.17 hrs, Volume= 0.100 af, Depth= 0.93"  
 Routed to Link 2L : Post-Development

Runoff by SCS TR-20 method, UH=SCS, Weighted-CN, Time Span= 0.00-72.00 hrs, dt= 0.01 hrs  
 MSE 24-hr 3 1-Yr Rainfall=2.40"

Area (ac)	CN	Description
* 0.061	98	Paved asphalt drive, HSG D
* 0.017	98	Paved walks, HSG D
0.037	98	Roofs, HSG D
* 0.176	98	Gravel Drive, HSG D
* 1.012	78	>75% Grass cover, Good, HSG D per ordinance
1.303	82	Weighted Average
1.012		77.67% Pervious Area
0.291		22.33% Impervious Area

Tc (min)	Length (feet)	Slope (ft/ft)	Velocity (ft/sec)	Capacity (cfs)	Description
8.9	100	0.0800	0.19		<b>Sheet Flow,</b> Grass: Dense n= 0.240 P2= 2.70"
0.6	75	0.0800	1.98		<b>Shallow Concentrated Flow,</b> Short Grass Pasture Kv= 7.0 fps
9.5	175	Total			

**Subcatchment 3S: North Constructed Site**

Hydrograph

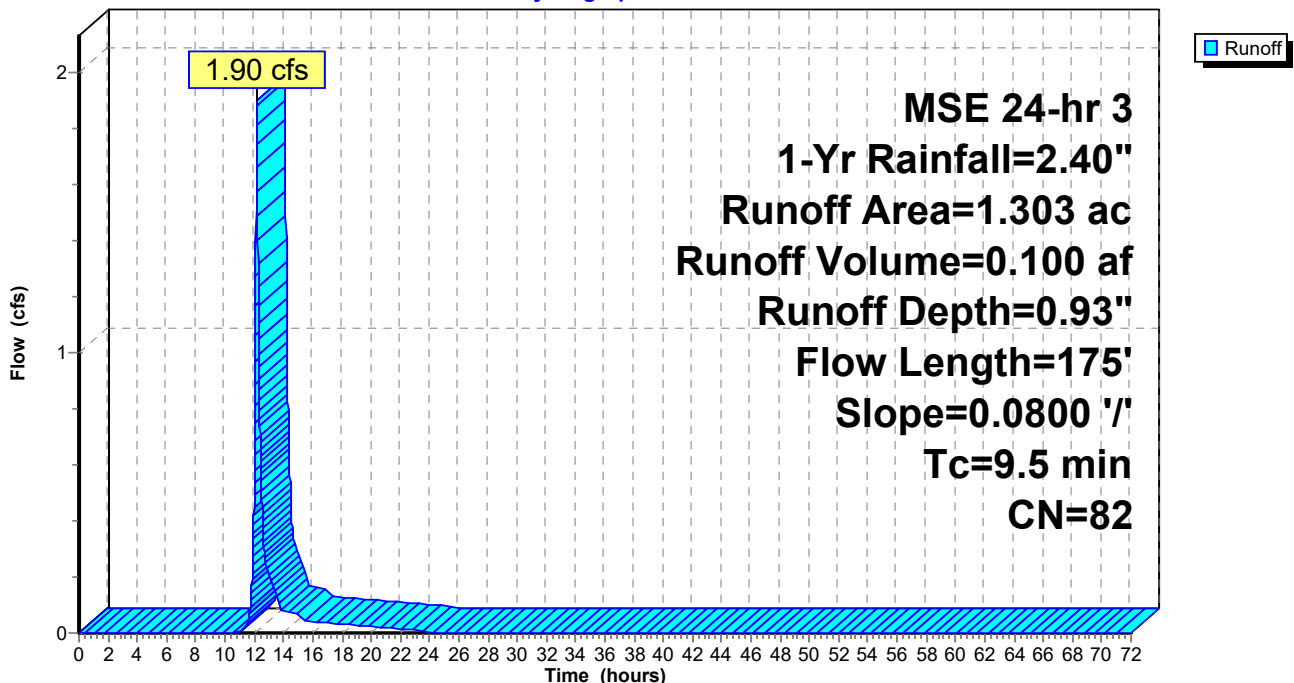

**Summary for Subcatchment 4aS: Offsite**

Runoff = 0.31 cfs @ 12.45 hrs, Volume= 0.031 af, Depth= 0.72"  
 Routed to Pond 1P : Wet Pond

Runoff by SCS TR-20 method, UH=SCS, Weighted-CN, Time Span= 0.00-72.00 hrs, dt= 0.01 hrs  
 MSE 24-hr 3 1-Yr Rainfall=2.40"

Area (ac)	CN	Description
* 0.509	78	
0.509		100.00% Pervious Area

Tc (min)	Length (feet)	Slope (ft/ft)	Velocity (ft/sec)	Capacity (cfs)	Description
29.4					Direct Entry,

**Subcatchment 4aS: Offsite**

Hydrograph

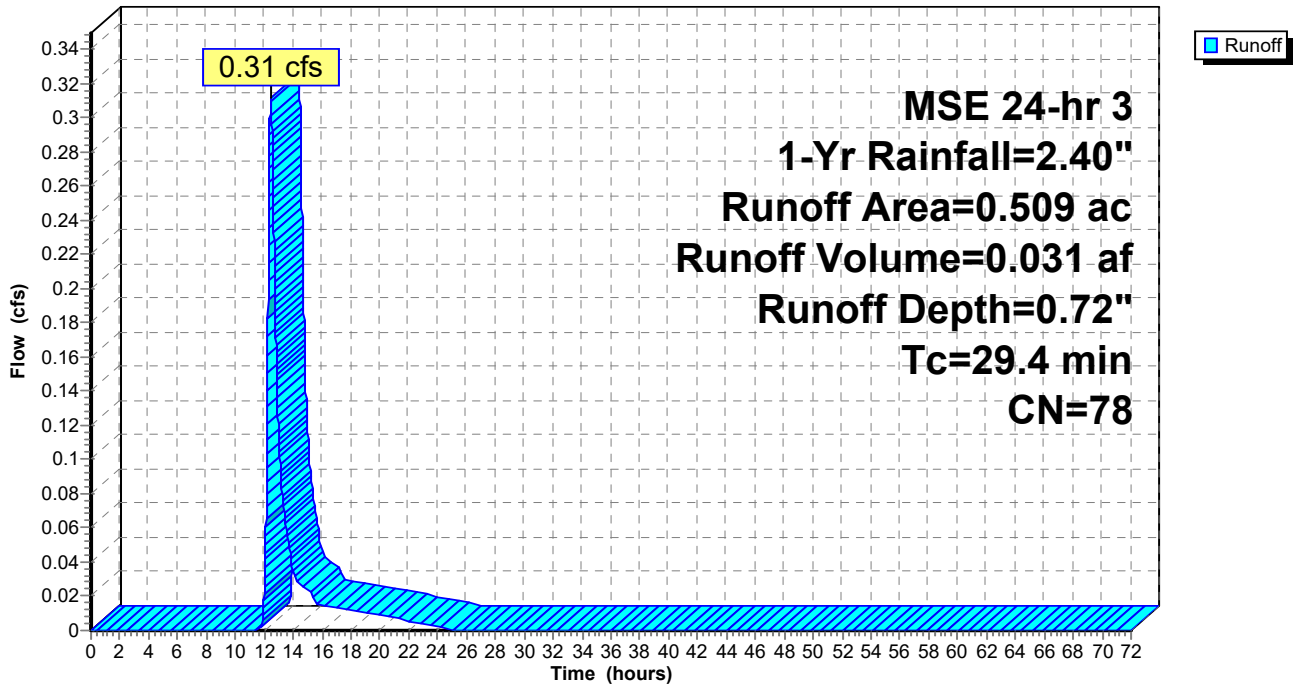

**Summary for Subcatchment 4bS: Offsite**

Runoff = 0.33 cfs @ 12.33 hrs, Volume= 0.026 af, Depth= 0.72"  
 Routed to Link 2L : Post-Development

Runoff by SCS TR-20 method, UH=SCS, Weighted-CN, Time Span= 0.00-72.00 hrs, dt= 0.01 hrs  
 MSE 24-hr 3 1-Yr Rainfall=2.40"

Area (ac)	CN	Description
* 0.432	78	
0.432		100.00% Pervious Area

Tc (min)	Length (feet)	Slope (ft/ft)	Velocity (ft/sec)	Capacity (cfs)	Description
20.3					Direct Entry,

**Subcatchment 4bS: Offsite**

Hydrograph

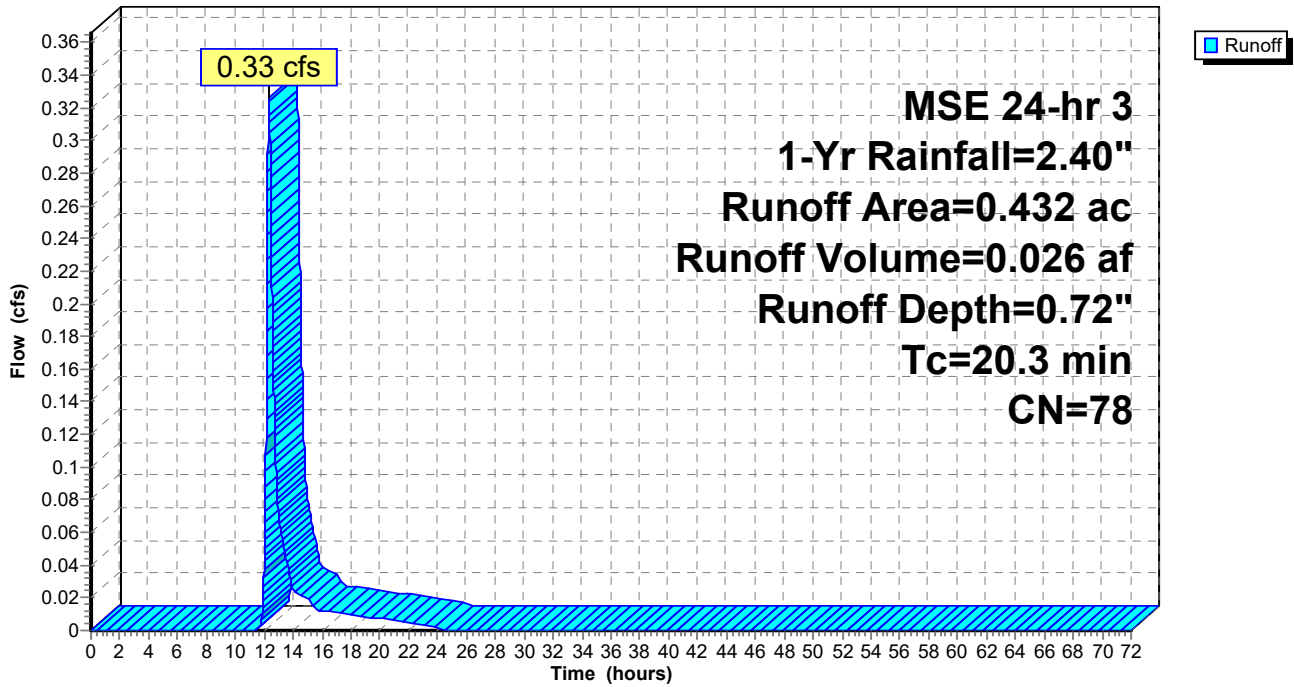

**Summary for Subcatchment 4S: South and East Constructed Site**

Runoff = 10.02 cfs @ 12.13 hrs, Volume= 0.455 af, Depth= 1.44"  
 Routed to Pond 1P : Wet Pond

Runoff by SCS TR-20 method, UH=SCS, Weighted-CN, Time Span= 0.00-72.00 hrs, dt= 0.01 hrs  
 MSE 24-hr 3 1-Yr Rainfall=2.40"

Area (ac)	CN	Description
* 2.143	98	Gravel Drive and Parking, HSG D
* 1.463	78	>75% Grass cover, Good, HSG D per ordinance
0.180	98	Water Surface, HSG D
3.786	90	Weighted Average
1.463		38.64% Pervious Area
2.323		61.36% Impervious Area

Tc (min)	Length (feet)	Slope (ft/ft)	Velocity (ft/sec)	Capacity (cfs)	Description
6.0					Direct Entry, Minimum

**Subcatchment 4S: South and East Constructed Site**

Hydrograph

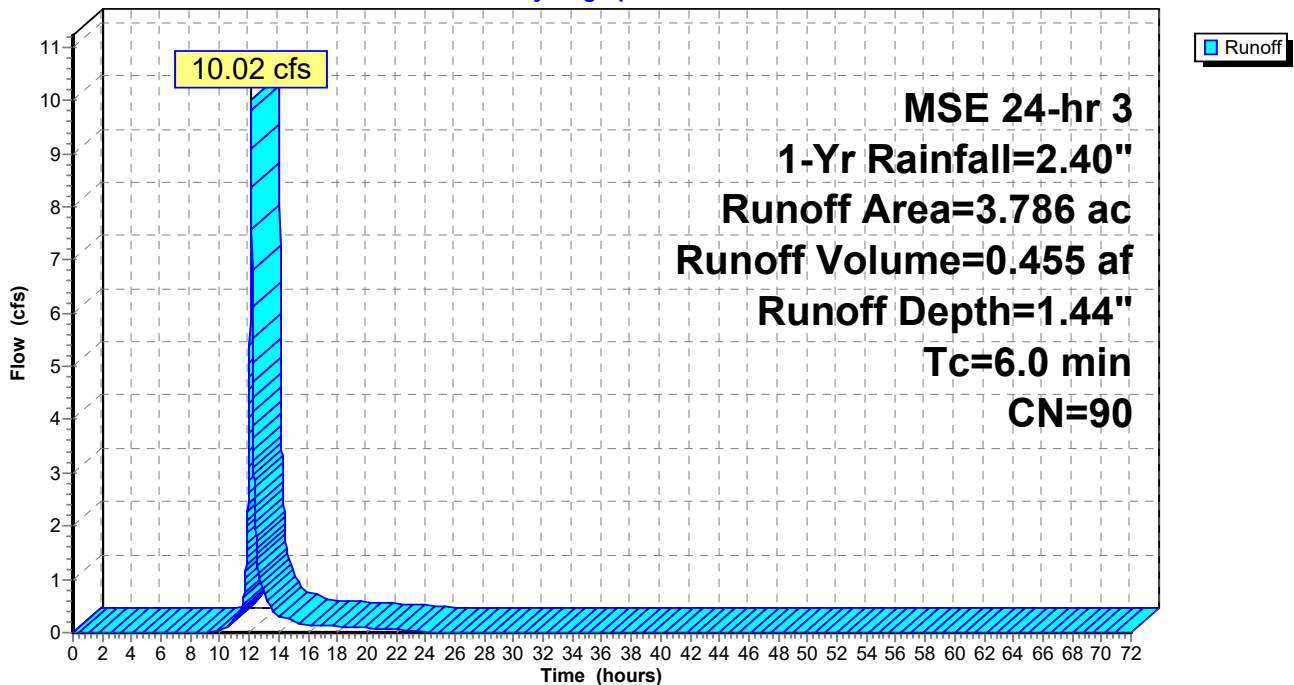



**Summary for Pond 1P: Wet Pond**

Inflow Area = 4.295 ac, 54.09% Impervious, Inflow Depth = 1.36" for 1-Yr event  
 Inflow = 10.10 cfs @ 12.13 hrs, Volume= 0.486 af  
 Outflow = 1.35 cfs @ 12.61 hrs, Volume= 0.485 af, Atten= 87%, Lag= 28.5 min  
 Primary = 1.35 cfs @ 12.61 hrs, Volume= 0.485 af  
 Routed to Link 2L : Post-Development  
 Secondary = 0.00 cfs @ 0.00 hrs, Volume= 0.000 af  
 Routed to Link 2L : Post-Development

Routing by Stor-Ind method, Time Span= 0.00-72.00 hrs, dt= 0.01 hrs  
 Peak Elev= 893.39' @ 12.61 hrs Surf.Area= 8,386 sf Storage= 10,164 cf

Plug-Flow detention time= 132.1 min calculated for 0.485 af (100% of inflow)  
 Center-of-Mass det. time= 132.1 min ( 932.9 - 800.8 )

Volume	Invert	Avail.Storage	Storage Description
#1	892.00'	37,068 cf	<b>Custom Stage Data (Prismatic)</b> Listed below (Recalc)
Elevation (feet)	Surf.Area (sq-ft)	Inc.Store (cubic-feet)	Cum.Store (cubic-feet)
892.00	6,098	0	0
893.00	7,827	6,963	6,963
894.00	9,243	8,535	15,498
895.00	10,760	10,002	25,499
896.00	12,378	11,569	37,068

Device	Routing	Invert	Outlet Devices
#1	Primary	892.00'	<b>24.0" Round Culvert</b> L= 24.0' RCP, groove end projecting, Ke= 0.200 Inlet / Outlet Invert= 892.00' / 891.52' S= 0.0200 1' Cc= 0.900 n= 0.013 Concrete pipe, bends & connections, Flow Area= 3.14 sf
#2	Device 1	892.00'	<b>7.0" Vert. Orifice/Grate</b> C= 0.600 Limited to weir flow at low heads
#3	Device 1	894.25'	<b>6.0' long x 0.5' breadth Top of Weir Plate</b> Head (feet) 0.20 0.40 0.60 0.80 1.00 Coef. (English) 2.80 2.92 3.08 3.30 3.32
#4	Secondary	895.15'	<b>20.0' long x 10.0' breadth Emergency Spillway</b> Head (feet) 0.20 0.40 0.60 0.80 1.00 1.20 1.40 1.60 Coef. (English) 2.49 2.56 2.70 2.69 2.68 2.69 2.67 2.64

**Primary OutFlow** Max=1.35 cfs @ 12.61 hrs HW=893.39' (Free Discharge)

- ↑ 1=Culvert (Passes 1.35 cfs of 9.96 cfs potential flow)
- ↑ 2=Orifice/Grate (Orifice Controls 1.35 cfs @ 5.06 fps)
- ↑ 3=Top of Weir Plate ( Controls 0.00 cfs)

**Secondary OutFlow** Max=0.00 cfs @ 0.00 hrs HW=892.00' (Free Discharge)

- ↑ 4=Emergency Spillway ( Controls 0.00 cfs)

### Pond 1P: Wet Pond

Hydrograph

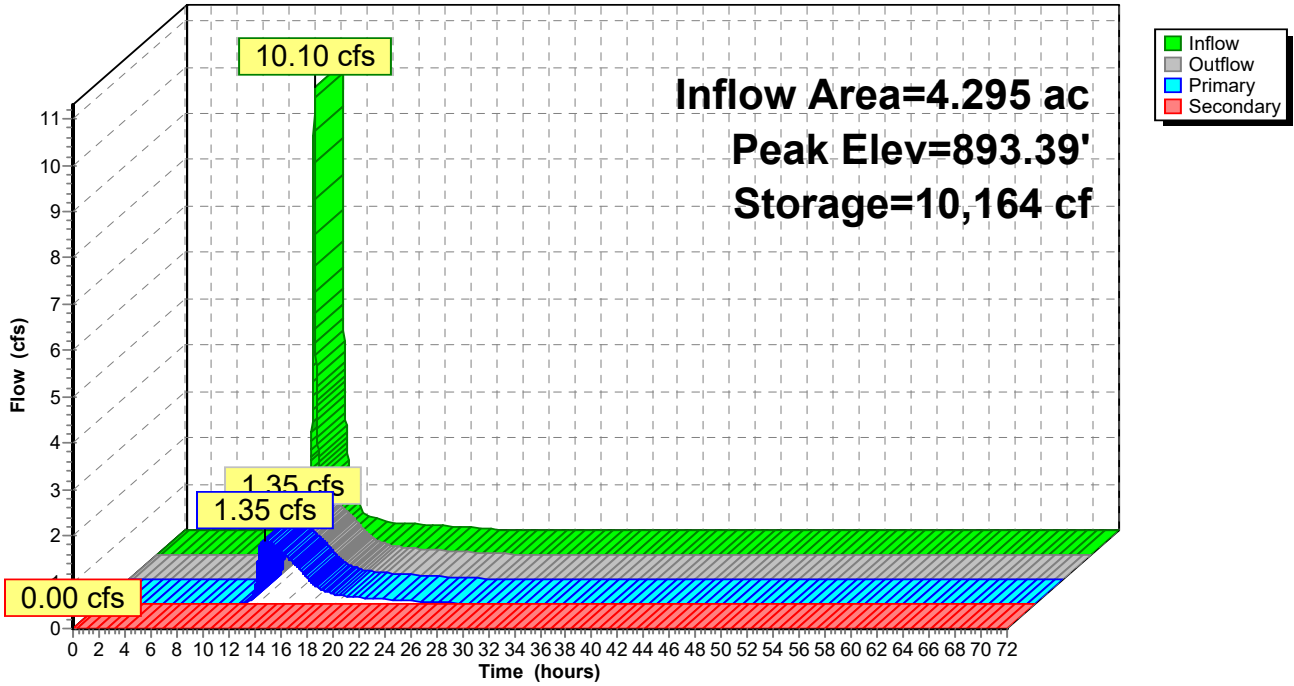

### Summary for Link 1L: Pre-Development

Inflow Area = 6.030 ac, 1.91% Impervious, Inflow Depth = 0.74" for 1-Yr event  
Inflow = 5.23 cfs @ 12.21 hrs, Volume= 0.371 af  
Primary = 5.23 cfs @ 12.21 hrs, Volume= 0.371 af, Atten= 0%, Lag= 0.0 min

Primary outflow = Inflow, Time Span= 0.00-72.00 hrs, dt= 0.01 hrs

### Link 1L: Pre-Development

Hydrograph

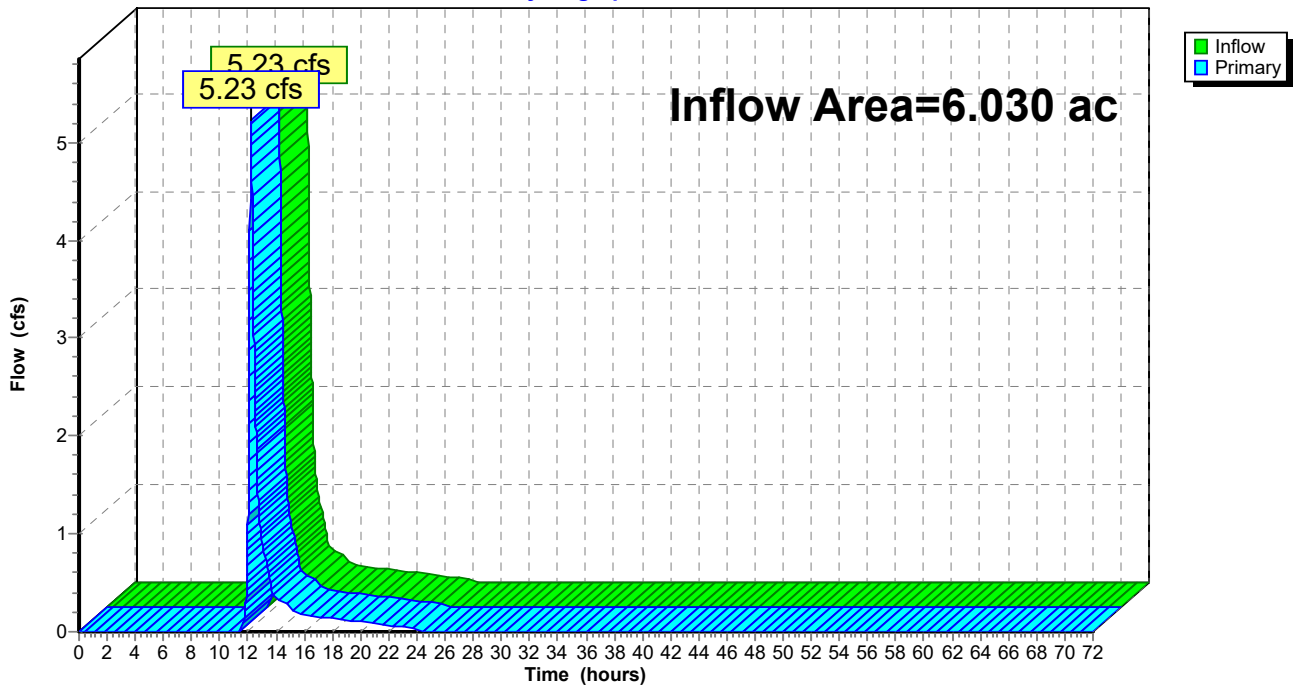

### Summary for Link 2L: Post-Development

Inflow Area = 6.030 ac, 43.35% Impervious, Inflow Depth = 1.22" for 1-Yr event  
Inflow = 3.25 cfs @ 12.19 hrs, Volume= 0.612 af  
Primary = 3.25 cfs @ 12.19 hrs, Volume= 0.612 af, Atten= 0%, Lag= 0.0 min

Primary outflow = Inflow, Time Span= 0.00-72.00 hrs, dt= 0.01 hrs

### Link 2L: Post-Development

Hydrograph

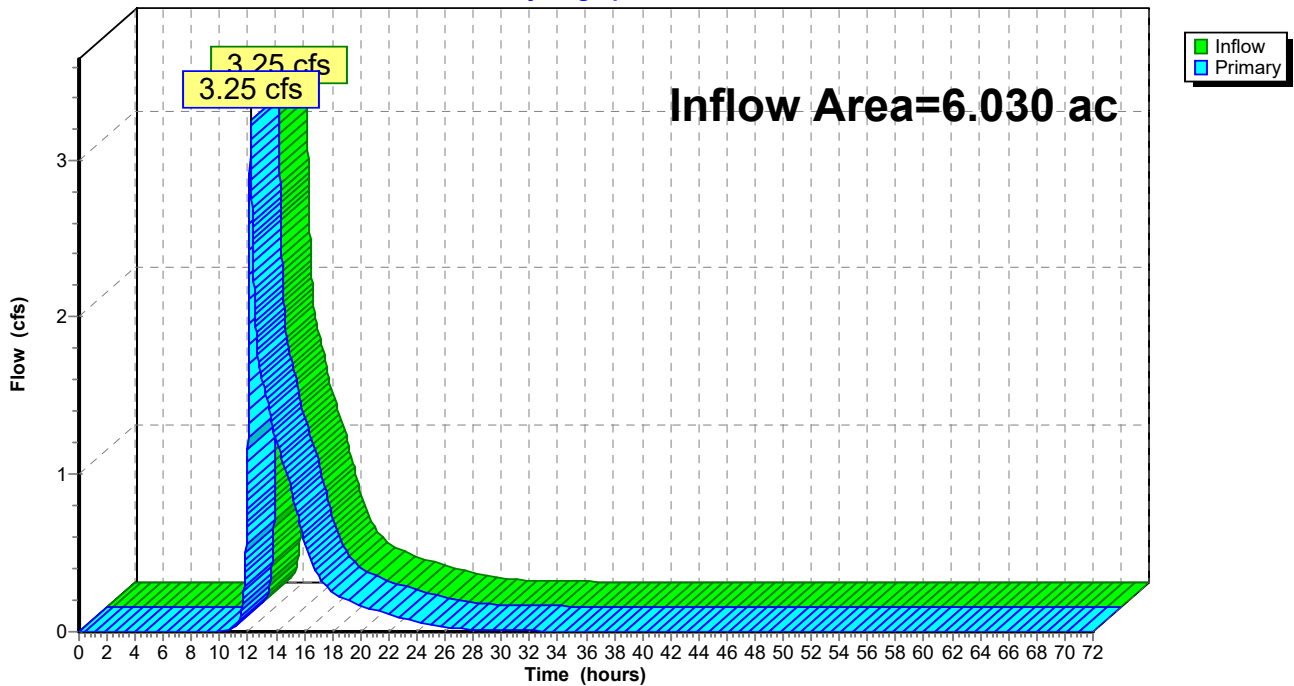

**Summary for Subcatchment 1S: North Original Site**

Runoff = 2.74 cfs @ 12.17 hrs, Volume= 0.145 af, Depth= 0.97"  
 Routed to Link 1L : Pre-Development

Runoff by SCS TR-20 method, UH=SCS, Weighted-CN, Time Span= 0.00-72.00 hrs, dt= 0.01 hrs  
 MSE 24-hr 3 2-Yr Rainfall=2.70"

Area (ac)	CN	Description
* 0.061	98	Paved asphalt drive, HSG D
* 0.017	98	Paved walks, HSG D
0.037	98	Roofs, HSG D
* 1.673	78	>75% Grass cover, Good, HSG D per ordinance
1.788	79	Weighted Average
1.673		93.57% Pervious Area
0.115		6.43% Impervious Area

Tc (min)	Length (feet)	Slope (ft/ft)	Velocity (ft/sec)	Capacity (cfs)	Description
8.9	100	0.0800	0.19		<b>Sheet Flow,</b> Grass: Dense n= 0.240 P2= 2.70"
0.6	75	0.0800	1.98		<b>Shallow Concentrated Flow,</b> Short Grass Pasture Kv= 7.0 fps
9.5	175	Total			

**Subcatchment 1S: North Original Site**

Hydrograph

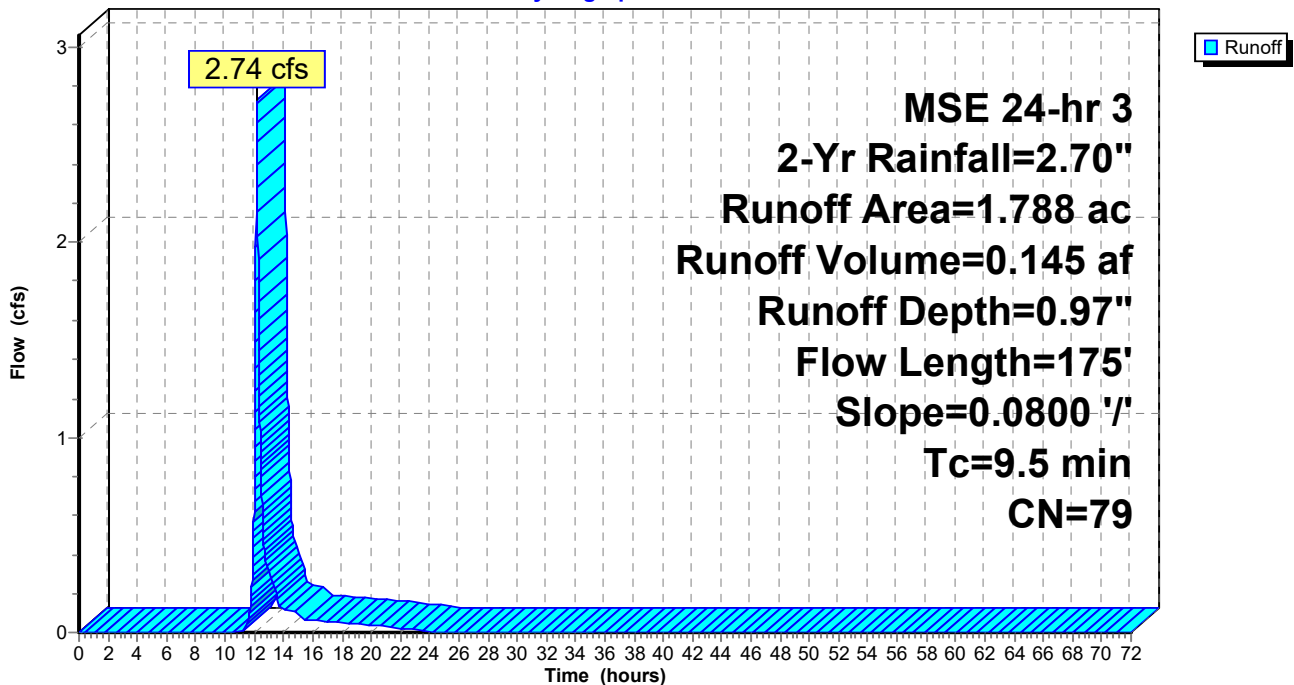

**Summary for Subcatchment 2aS: Offsite**

Runoff = 0.75 cfs @ 12.45 hrs, Volume= 0.072 af, Depth= 0.92"  
 Routed to Link 1L : Pre-Development

Runoff by SCS TR-20 method, UH=SCS, Weighted-CN, Time Span= 0.00-72.00 hrs, dt= 0.01 hrs  
 MSE 24-hr 3 2-Yr Rainfall=2.70"

Area (ac)	CN	Description
* 0.941	78	>75% Grass cover, Good, HSG D per ordinance
0.941		100.00% Pervious Area

Tc (min)	Length (feet)	Slope (ft/ft)	Velocity (ft/sec)	Capacity (cfs)	Description
29.4					Direct Entry,

**Subcatchment 2aS: Offsite**

Hydrograph

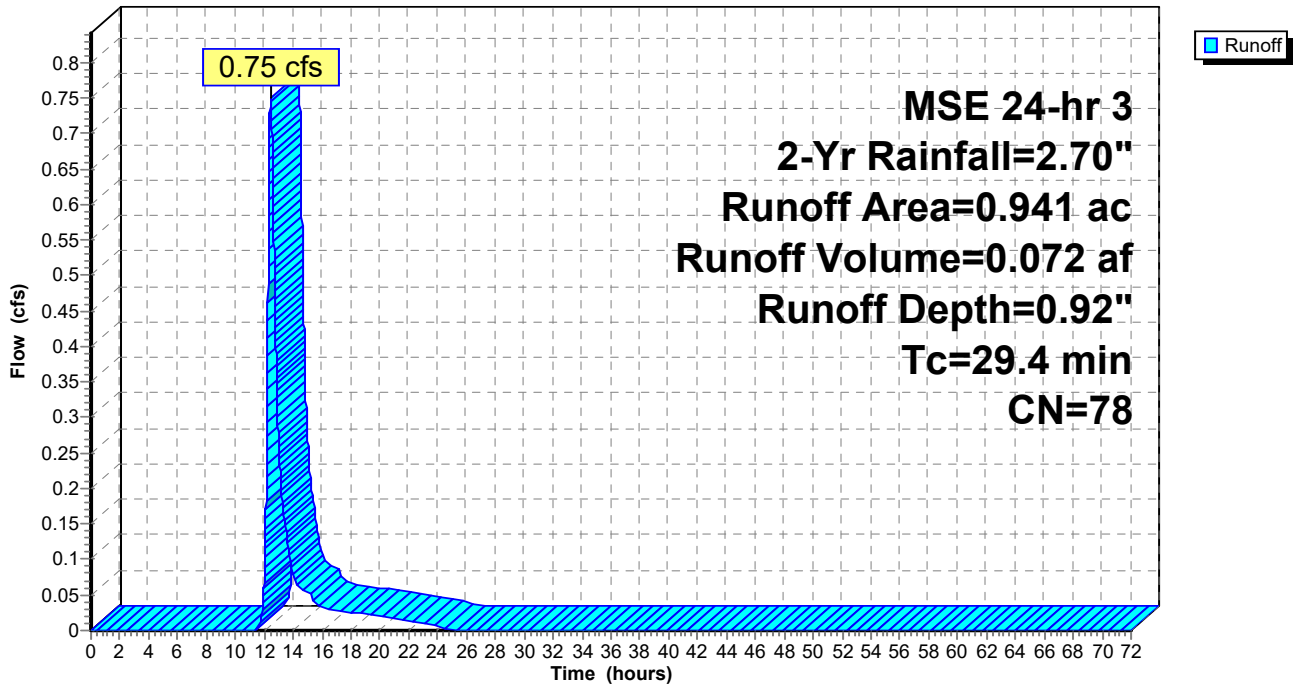

**Summary for Subcatchment 2S: South and East Original Site**

Runoff = 3.97 cfs @ 12.23 hrs, Volume= 0.253 af, Depth= 0.92"  
 Routed to Link 1L : Pre-Development

Runoff by SCS TR-20 method, UH=SCS, Weighted-CN, Time Span= 0.00-72.00 hrs, dt= 0.01 hrs  
 MSE 24-hr 3 2-Yr Rainfall=2.70"

Area (ac)	CN	Description
* 3.301	78	>75% Grass cover, Good, HSG D per ordinance
3.301		100.00% Pervious Area

Tc (min)	Length (feet)	Slope (ft/ft)	Velocity (ft/sec)	Capacity (cfs)	Description
10.0	100	0.0600	0.17		Sheet Flow, Grass: Dense n= 0.240 P2= 2.70"
3.8	475	0.0900	2.10		Shallow Concentrated Flow, Short Grass Pasture Kv= 7.0 fps
13.8	575	Total			

**Subcatchment 2S: South and East Original Site**

Hydrograph



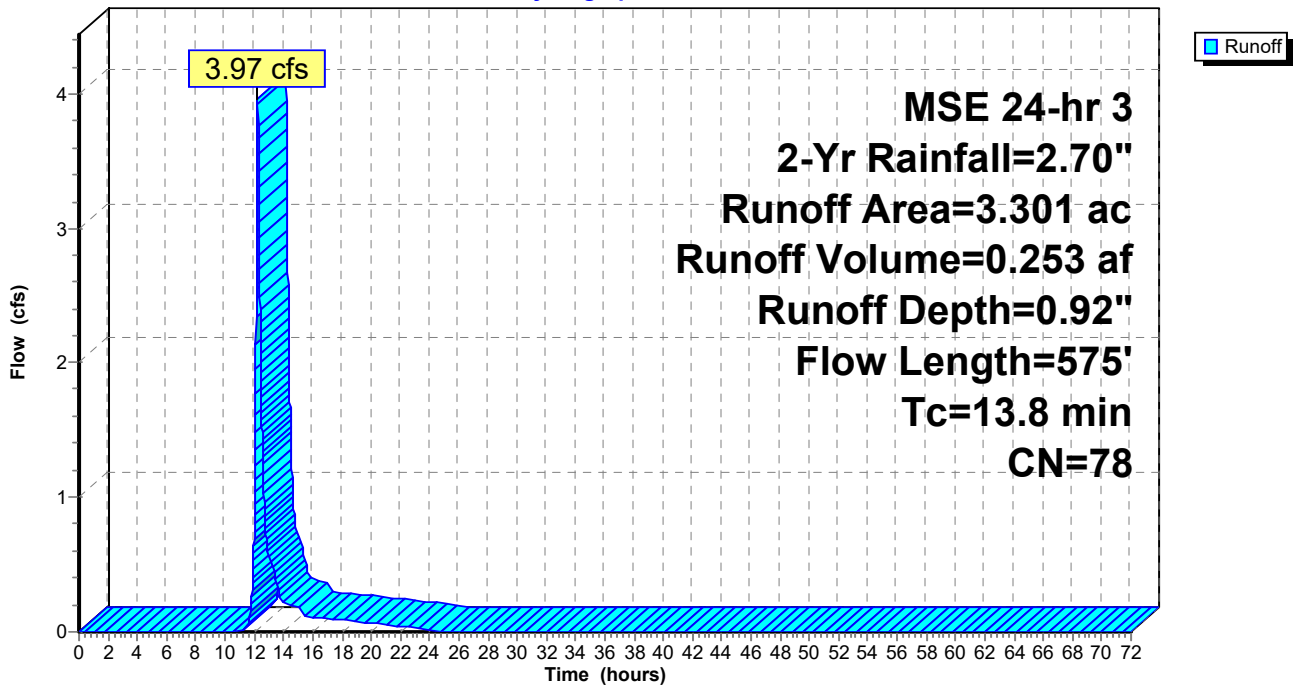

**Summary for Subcatchment 3S: North Constructed Site**

Runoff = 2.38 cfs @ 12.17 hrs, Volume= 0.125 af, Depth= 1.15"  
 Routed to Link 2L : Post-Development

Runoff by SCS TR-20 method, UH=SCS, Weighted-CN, Time Span= 0.00-72.00 hrs, dt= 0.01 hrs  
 MSE 24-hr 3 2-Yr Rainfall=2.70"

Area (ac)	CN	Description
* 0.061	98	Paved asphalt drive, HSG D
* 0.017	98	Paved walks, HSG D
0.037	98	Roofs, HSG D
* 0.176	98	Gravel Drive, HSG D
* 1.012	78	>75% Grass cover, Good, HSG D per ordinance
1.303	82	Weighted Average
1.012		77.67% Pervious Area
0.291		22.33% Impervious Area

Tc (min)	Length (feet)	Slope (ft/ft)	Velocity (ft/sec)	Capacity (cfs)	Description
8.9	100	0.0800	0.19		<b>Sheet Flow,</b> Grass: Dense n= 0.240 P2= 2.70"
0.6	75	0.0800	1.98		<b>Shallow Concentrated Flow,</b> Short Grass Pasture Kv= 7.0 fps
9.5	175	Total			

**Subcatchment 3S: North Constructed Site**

Hydrograph

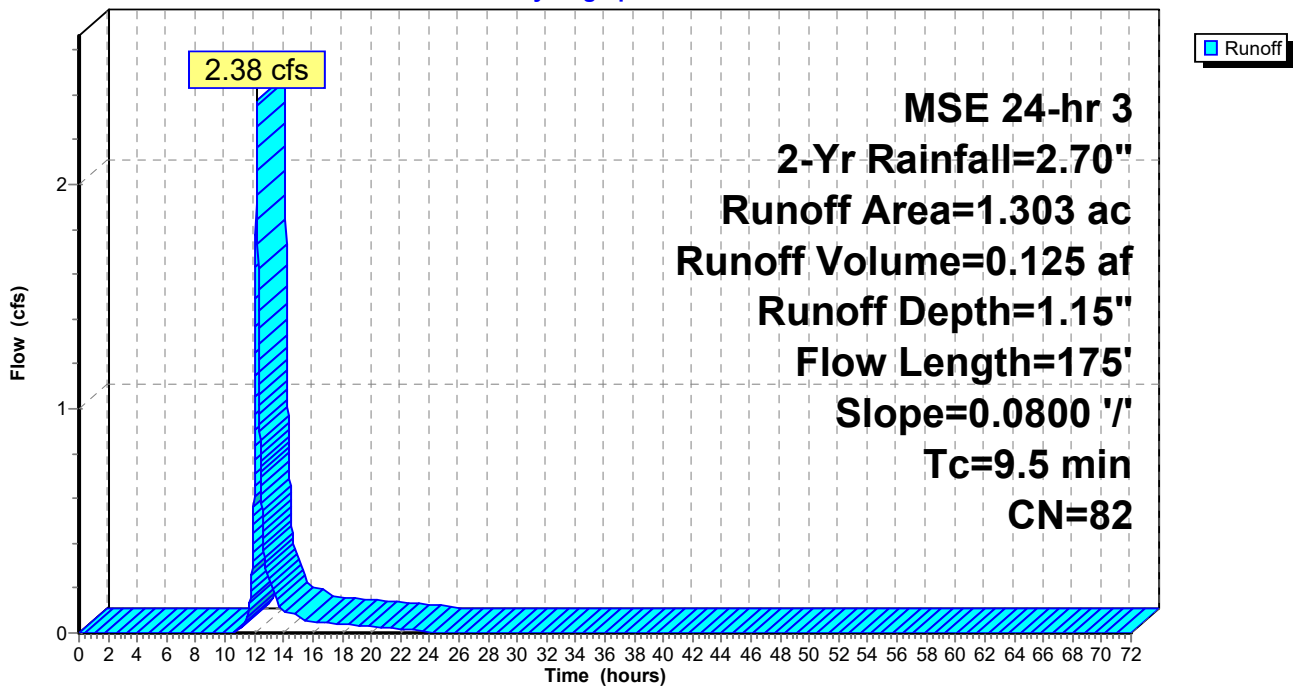

**Summary for Subcatchment 4aS: Offsite**

Runoff = 0.41 cfs @ 12.45 hrs, Volume= 0.039 af, Depth= 0.92"  
 Routed to Pond 1P : Wet Pond

Runoff by SCS TR-20 method, UH=SCS, Weighted-CN, Time Span= 0.00-72.00 hrs, dt= 0.01 hrs  
 MSE 24-hr 3 2-Yr Rainfall=2.70"

Area (ac)	CN	Description
* 0.509	78	
0.509		100.00% Pervious Area

Tc (min)	Length (feet)	Slope (ft/ft)	Velocity (ft/sec)	Capacity (cfs)	Description
29.4					Direct Entry,

**Subcatchment 4aS: Offsite**

Hydrograph

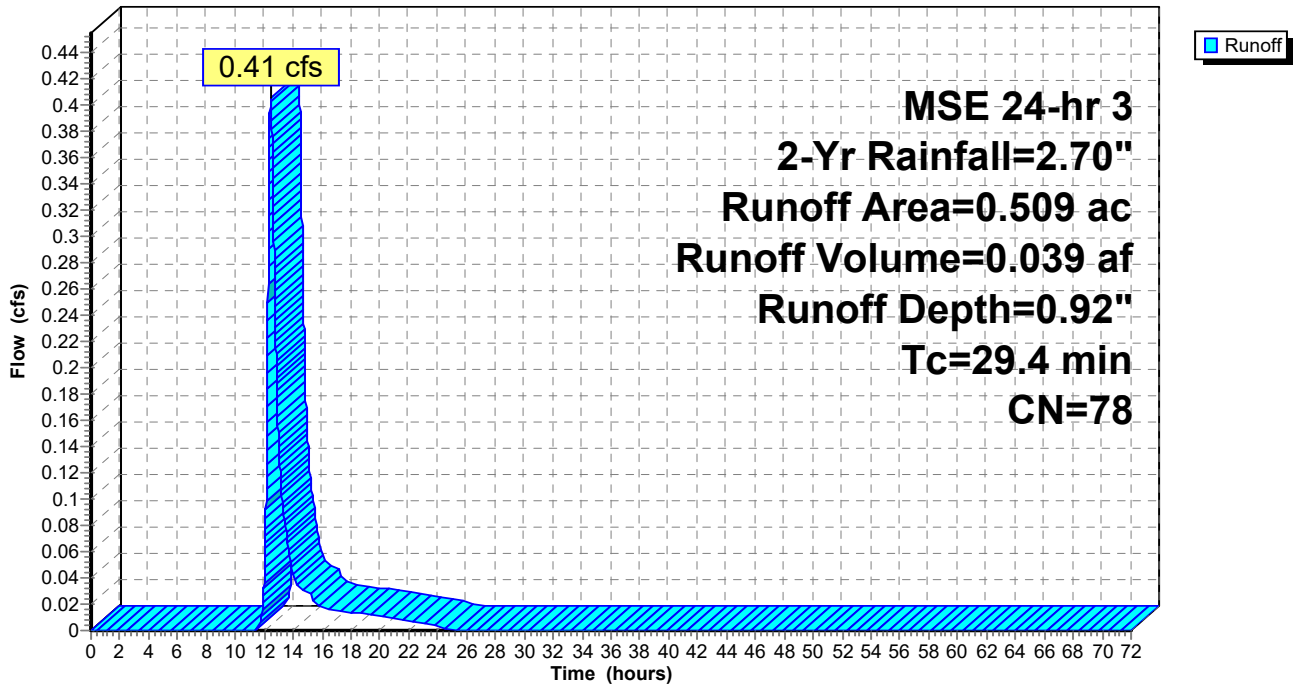

**Summary for Subcatchment 4bS: Offsite**

Runoff = 0.42 cfs @ 12.32 hrs, Volume= 0.033 af, Depth= 0.92"  
 Routed to Link 2L : Post-Development

Runoff by SCS TR-20 method, UH=SCS, Weighted-CN, Time Span= 0.00-72.00 hrs, dt= 0.01 hrs  
 MSE 24-hr 3 2-Yr Rainfall=2.70"

Area (ac)	CN	Description
* 0.432	78	
0.432		100.00% Pervious Area

Tc (min)	Length (feet)	Slope (ft/ft)	Velocity (ft/sec)	Capacity (cfs)	Description
20.3					Direct Entry,

**Subcatchment 4bS: Offsite**

Hydrograph

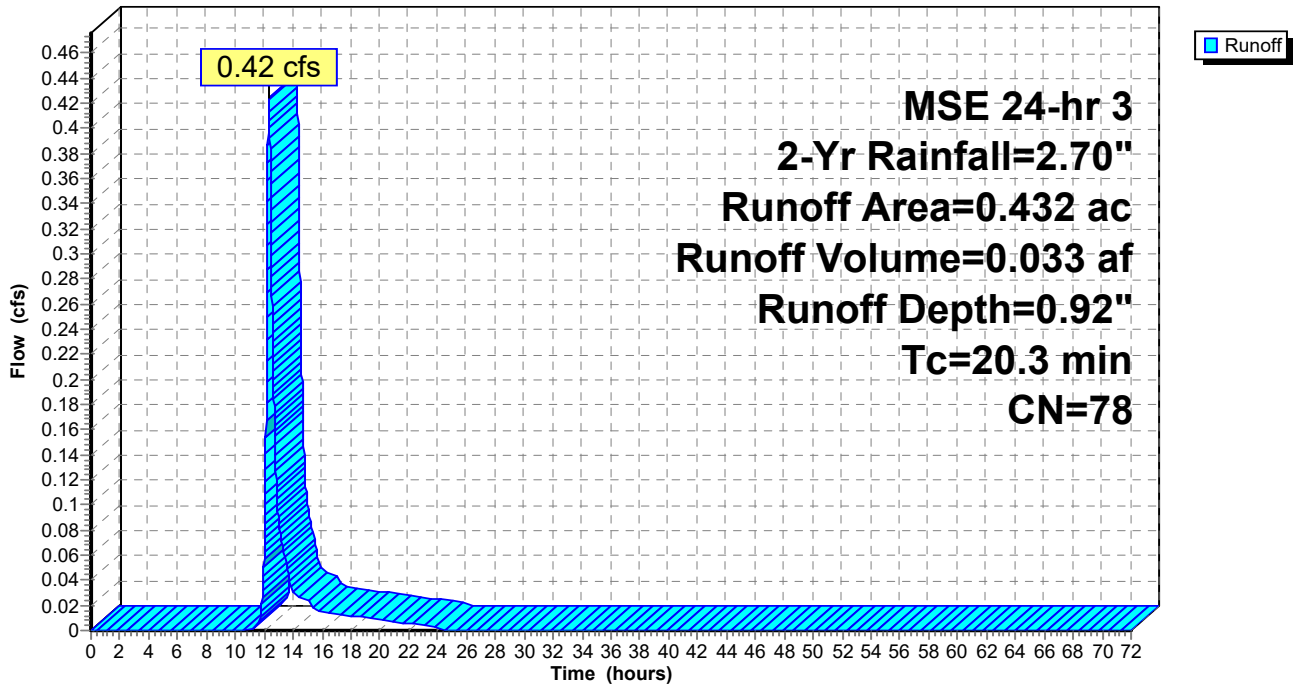

**Summary for Subcatchment 4S: South and East Constructed Site**

Runoff = 11.81 cfs @ 12.13 hrs, Volume= 0.540 af, Depth= 1.71"  
 Routed to Pond 1P : Wet Pond

Runoff by SCS TR-20 method, UH=SCS, Weighted-CN, Time Span= 0.00-72.00 hrs, dt= 0.01 hrs  
 MSE 24-hr 3 2-Yr Rainfall=2.70"

Area (ac)	CN	Description
* 2.143	98	Gravel Drive and Parking, HSG D
* 1.463	78	>75% Grass cover, Good, HSG D per ordinance
0.180	98	Water Surface, HSG D
3.786	90	Weighted Average
1.463		38.64% Pervious Area
2.323		61.36% Impervious Area

Tc (min)	Length (feet)	Slope (ft/ft)	Velocity (ft/sec)	Capacity (cfs)	Description
6.0					Direct Entry, Minimum

**Subcatchment 4S: South and East Constructed Site**

Hydrograph

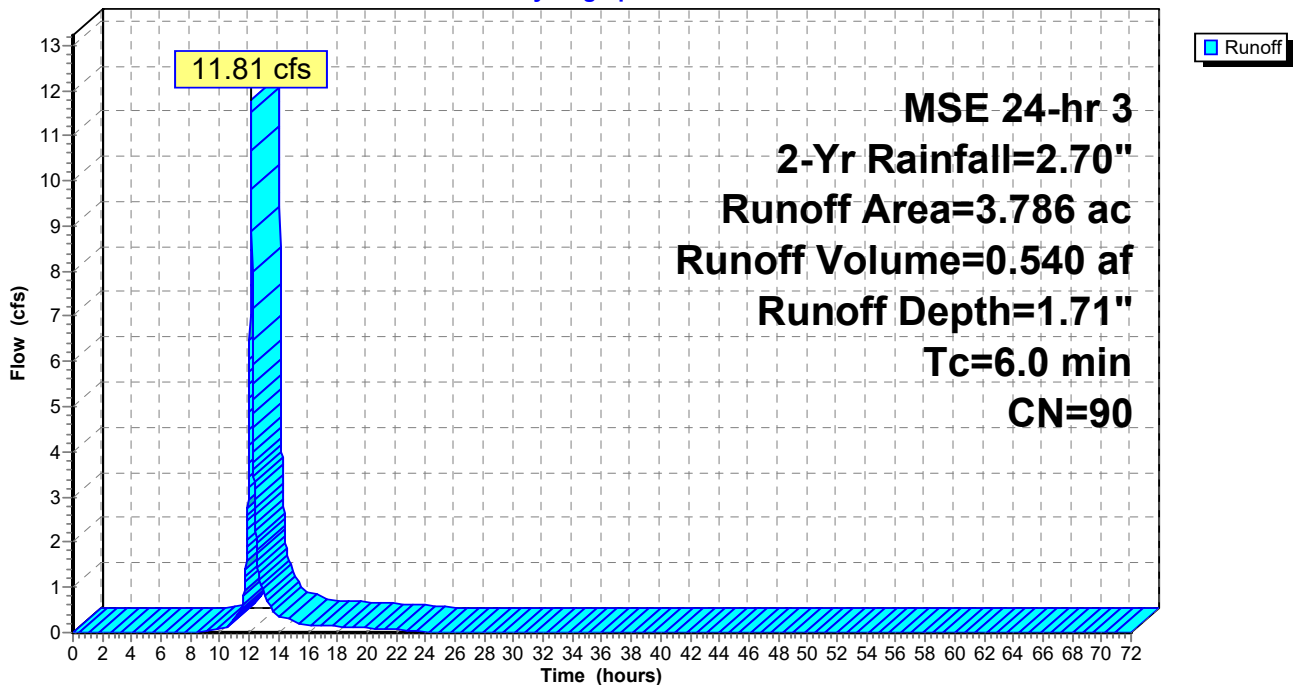

**Summary for Pond 1P: Wet Pond**

Inflow Area = 4.295 ac, 54.09% Impervious, Inflow Depth = 1.62" for 2-Yr event  
 Inflow = 11.92 cfs @ 12.13 hrs, Volume= 0.579 af  
 Outflow = 1.50 cfs @ 12.64 hrs, Volume= 0.579 af, Atten= 87%, Lag= 30.2 min  
 Primary = 1.50 cfs @ 12.64 hrs, Volume= 0.579 af  
 Routed to Link 2L : Post-Development  
 Secondary = 0.00 cfs @ 0.00 hrs, Volume= 0.000 af  
 Routed to Link 2L : Post-Development

Routing by Stor-Ind method, Time Span= 0.00-72.00 hrs, dt= 0.01 hrs  
 Peak Elev= 893.65' @ 12.64 hrs Surf.Area= 8,748 sf Storage= 12,354 cf

Plug-Flow detention time= 133.5 min calculated for 0.578 af (100% of inflow)  
 Center-of-Mass det. time= 133.6 min ( 931.1 - 797.4 )

Volume	Invert	Avail.Storage	Storage Description
#1	892.00'	37,068 cf	<b>Custom Stage Data (Prismatic)</b> Listed below (Recalc)
Elevation (feet)	Surf.Area (sq-ft)	Inc.Store (cubic-feet)	Cum.Store (cubic-feet)
892.00	6,098	0	0
893.00	7,827	6,963	6,963
894.00	9,243	8,535	15,498
895.00	10,760	10,002	25,499
896.00	12,378	11,569	37,068

Device	Routing	Invert	Outlet Devices
#1	Primary	892.00'	<b>24.0" Round Culvert</b> L= 24.0' RCP, groove end projecting, Ke= 0.200 Inlet / Outlet Invert= 892.00' / 891.52' S= 0.0200 1' Cc= 0.900 n= 0.013 Concrete pipe, bends & connections, Flow Area= 3.14 sf
#2	Device 1	892.00'	<b>7.0" Vert. Orifice/Grate</b> C= 0.600 Limited to weir flow at low heads
#3	Device 1	894.25'	<b>6.0' long x 0.5' breadth Top of Weir Plate</b> Head (feet) 0.20 0.40 0.60 0.80 1.00 Coef. (English) 2.80 2.92 3.08 3.30 3.32
#4	Secondary	895.15'	<b>20.0' long x 10.0' breadth Emergency Spillway</b> Head (feet) 0.20 0.40 0.60 0.80 1.00 1.20 1.40 1.60 Coef. (English) 2.49 2.56 2.70 2.69 2.68 2.69 2.67 2.64

**Primary OutFlow** Max=1.50 cfs @ 12.64 hrs HW=893.65' (Free Discharge)

- ↑ 1=Culvert (Passes 1.50 cfs of 12.84 cfs potential flow)
- ↑ 2=Orifice/Grate (Orifice Controls 1.50 cfs @ 5.61 fps)
- ↑ 3=Top of Weir Plate ( Controls 0.00 cfs)

**Secondary OutFlow** Max=0.00 cfs @ 0.00 hrs HW=892.00' (Free Discharge)

- ↑ 4=Emergency Spillway ( Controls 0.00 cfs)

### Pond 1P: Wet Pond

Hydrograph

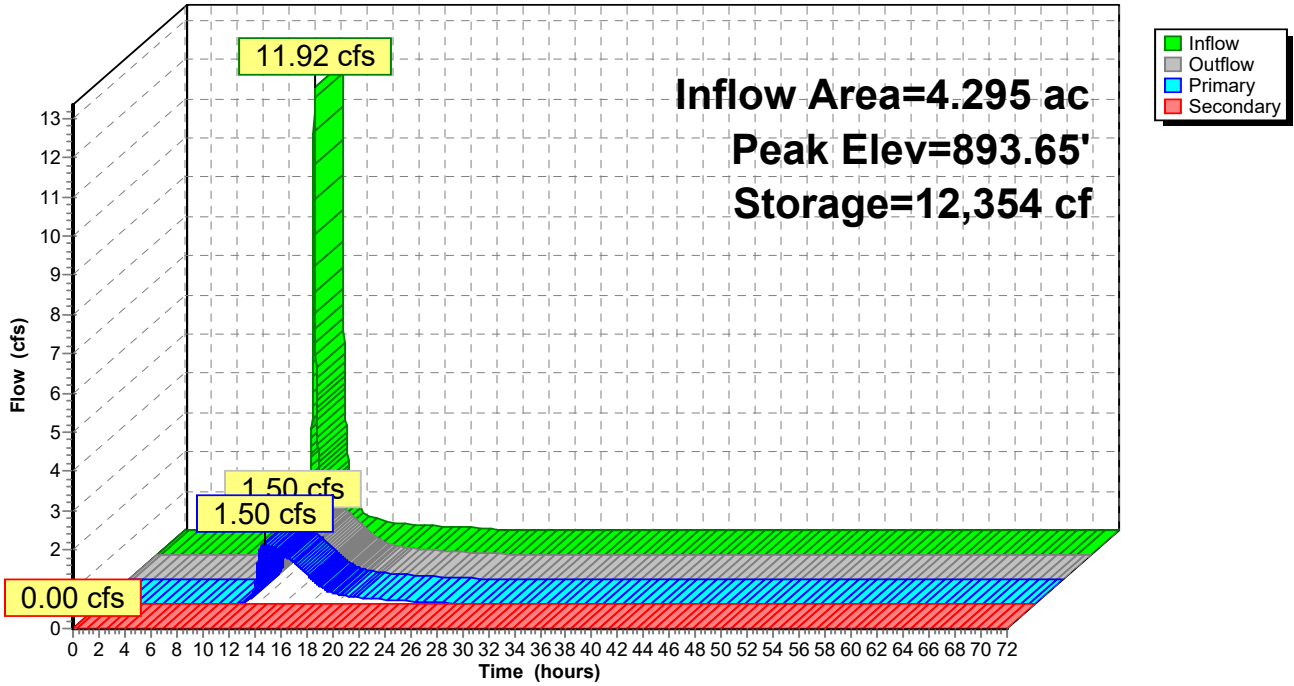

### Summary for Link 1L: Pre-Development

Inflow Area = 6.030 ac, 1.91% Impervious, Inflow Depth = 0.94" for 2-Yr event  
Inflow = 6.78 cfs @ 12.21 hrs, Volume= 0.471 af  
Primary = 6.78 cfs @ 12.21 hrs, Volume= 0.471 af, Atten= 0%, Lag= 0.0 min

Primary outflow = Inflow, Time Span= 0.00-72.00 hrs, dt= 0.01 hrs

### Link 1L: Pre-Development

Hydrograph

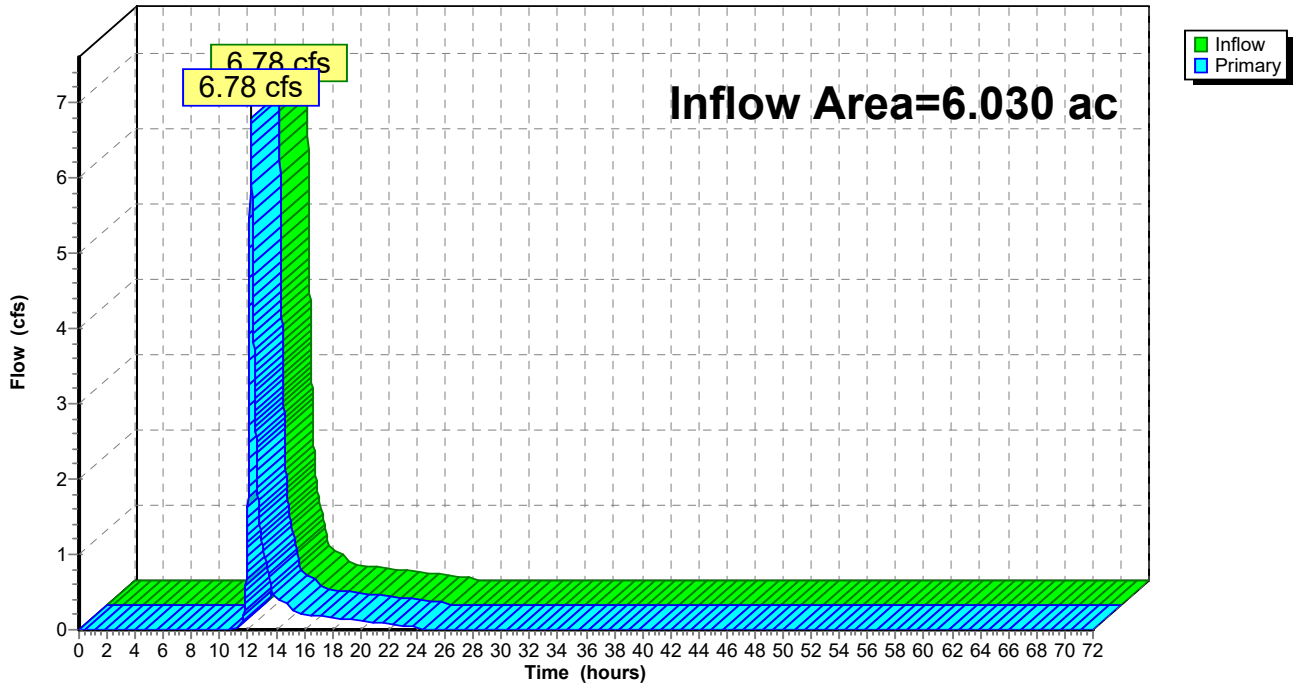

### Summary for Link 2L: Post-Development

Inflow Area = 6.030 ac, 43.35% Impervious, Inflow Depth = 1.47" for 2-Yr event  
Inflow = 3.92 cfs @ 12.19 hrs, Volume= 0.736 af  
Primary = 3.92 cfs @ 12.19 hrs, Volume= 0.736 af, Atten= 0%, Lag= 0.0 min

Primary outflow = Inflow, Time Span= 0.00-72.00 hrs, dt= 0.01 hrs

### Link 2L: Post-Development

Hydrograph

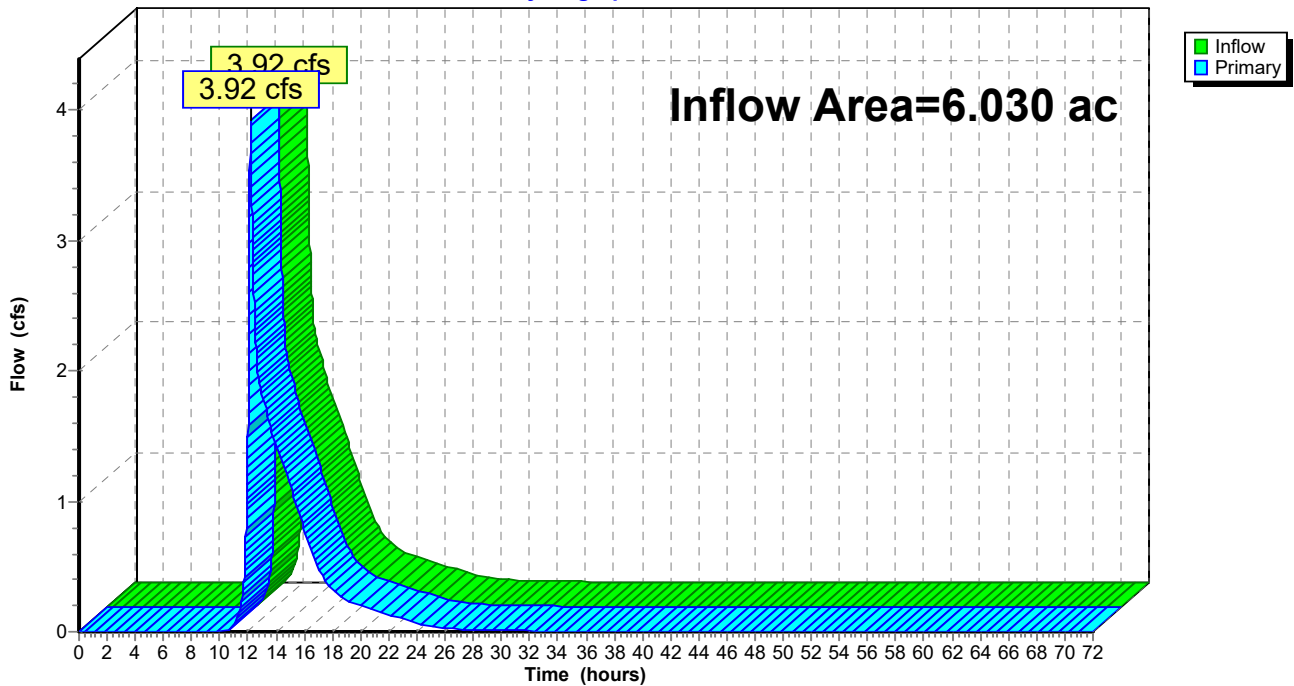



**Summary for Subcatchment 1S: North Original Site**

Runoff = 5.16 cfs @ 12.17 hrs, Volume= 0.270 af, Depth= 1.81"  
 Routed to Link 1L : Pre-Development

Runoff by SCS TR-20 method, UH=SCS, Weighted-CN, Time Span= 0.00-72.00 hrs, dt= 0.01 hrs  
 MSE 24-hr 3 10-Yr Rainfall=3.81"

Area (ac)	CN	Description
* 0.061	98	Paved asphalt drive, HSG D
* 0.017	98	Paved walks, HSG D
0.037	98	Roofs, HSG D
* 1.673	78	>75% Grass cover, Good, HSG D per ordinance
1.788	79	Weighted Average
1.673		93.57% Pervious Area
0.115		6.43% Impervious Area

Tc (min)	Length (feet)	Slope (ft/ft)	Velocity (ft/sec)	Capacity (cfs)	Description
8.9	100	0.0800	0.19		<b>Sheet Flow,</b> Grass: Dense n= 0.240 P2= 2.70"
0.6	75	0.0800	1.98		<b>Shallow Concentrated Flow,</b> Short Grass Pasture Kv= 7.0 fps
9.5	175	Total			

**Subcatchment 1S: North Original Site**

Hydrograph

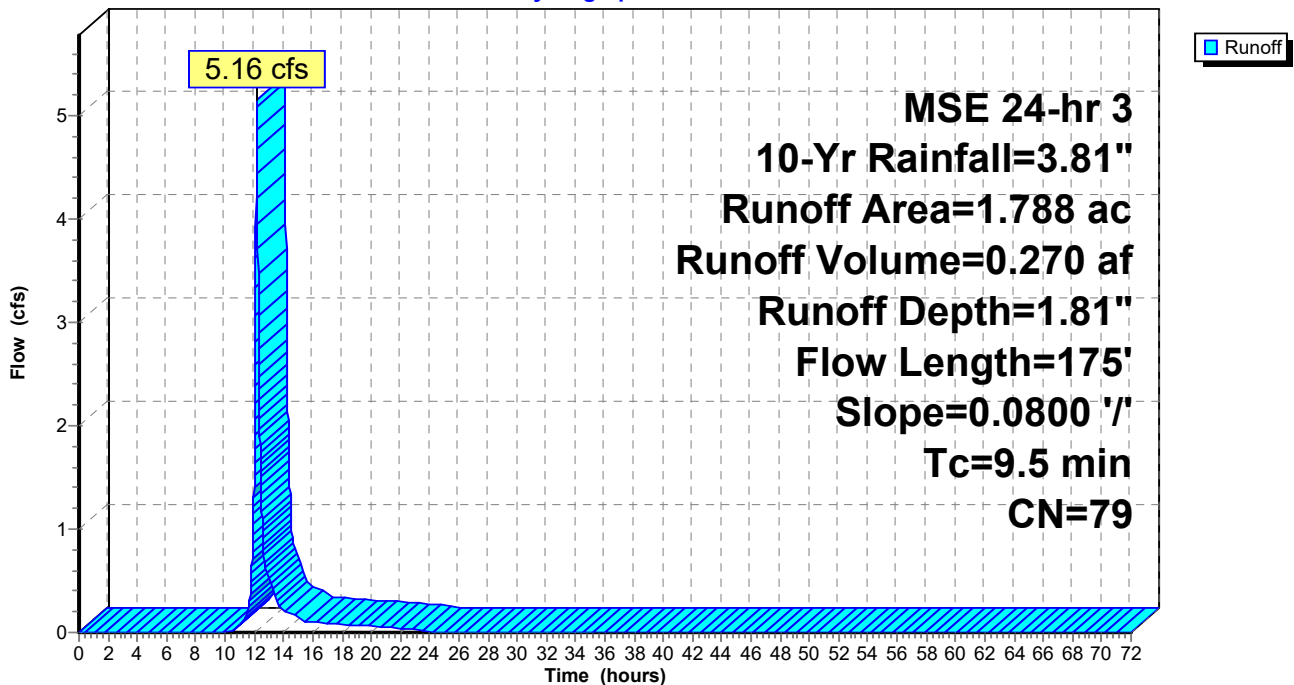

### Summary for Subcatchment 2aS: Offsite

Runoff = 1.47 cfs @ 12.44 hrs, Volume= 0.136 af, Depth= 1.74"  
Routed to Link 1L : Pre-Development

Runoff by SCS TR-20 method, UH=SCS, Weighted-CN, Time Span= 0.00-72.00 hrs, dt= 0.01 hrs  
MSE 24-hr 3 10-Yr Rainfall=3.81"

Area (ac)	CN	Description
* 0.941	78	>75% Grass cover, Good, HSG D per ordinance
0.941		100.00% Pervious Area

Tc (min)	Length (feet)	Slope (ft/ft)	Velocity (ft/sec)	Capacity (cfs)	Description
29.4					Direct Entry,

### Subcatchment 2aS: Offsite

Hydrograph

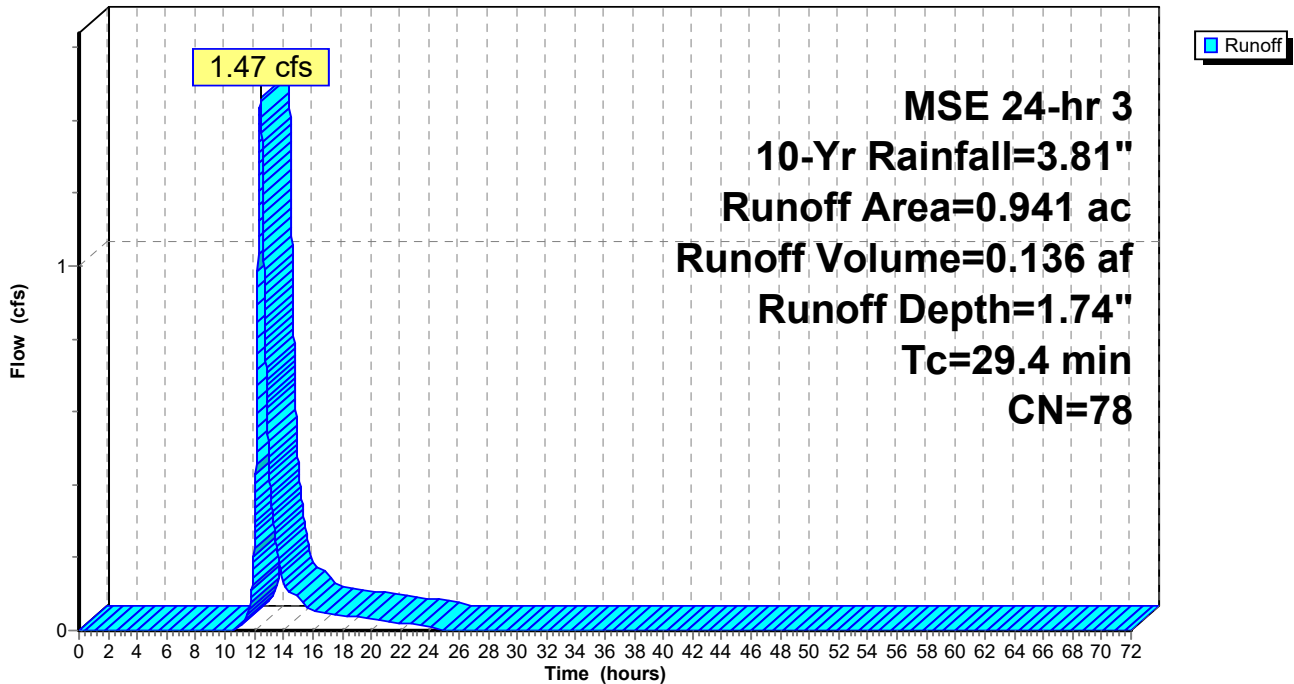

**Summary for Subcatchment 2S: South and East Original Site**

Runoff = 7.70 cfs @ 12.22 hrs, Volume= 0.478 af, Depth= 1.74"  
 Routed to Link 1L : Pre-Development

Runoff by SCS TR-20 method, UH=SCS, Weighted-CN, Time Span= 0.00-72.00 hrs, dt= 0.01 hrs  
 MSE 24-hr 3 10-Yr Rainfall=3.81"

Area (ac)	CN	Description
* 3.301	78	>75% Grass cover, Good, HSG D per ordinance
3.301		100.00% Pervious Area

Tc (min)	Length (feet)	Slope (ft/ft)	Velocity (ft/sec)	Capacity (cfs)	Description
10.0	100	0.0600	0.17		Sheet Flow, Grass: Dense n= 0.240 P2= 2.70"
3.8	475	0.0900	2.10		Shallow Concentrated Flow, Short Grass Pasture Kv= 7.0 fps
13.8	575	Total			

**Subcatchment 2S: South and East Original Site**

Hydrograph

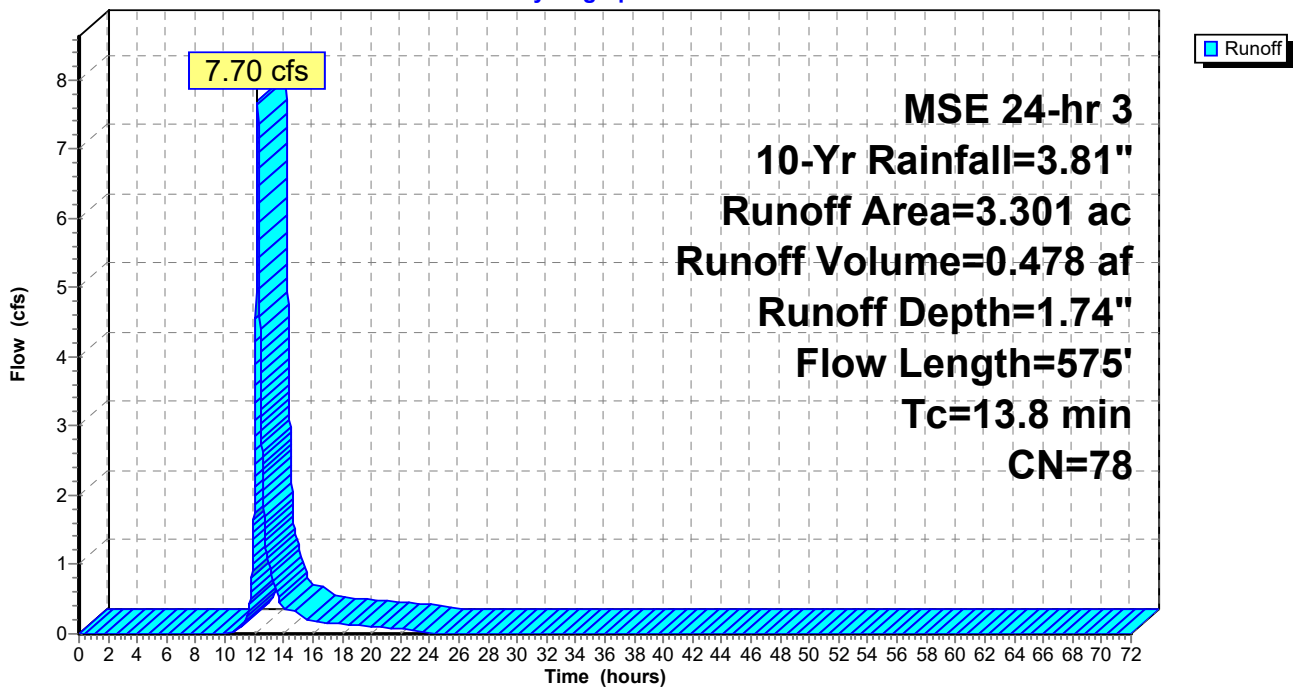

**Summary for Subcatchment 3S: North Constructed Site**

Runoff = 4.24 cfs @ 12.17 hrs, Volume= 0.222 af, Depth= 2.04"  
 Routed to Link 2L : Post-Development

Runoff by SCS TR-20 method, UH=SCS, Weighted-CN, Time Span= 0.00-72.00 hrs, dt= 0.01 hrs  
 MSE 24-hr 3 10-Yr Rainfall=3.81"

Area (ac)	CN	Description
* 0.061	98	Paved asphalt drive, HSG D
* 0.017	98	Paved walks, HSG D
0.037	98	Roofs, HSG D
* 0.176	98	Gravel Drive, HSG D
* 1.012	78	>75% Grass cover, Good, HSG D per ordinance
1.303	82	Weighted Average
1.012		77.67% Pervious Area
0.291		22.33% Impervious Area

Tc (min)	Length (feet)	Slope (ft/ft)	Velocity (ft/sec)	Capacity (cfs)	Description
8.9	100	0.0800	0.19		<b>Sheet Flow,</b> Grass: Dense n= 0.240 P2= 2.70"
0.6	75	0.0800	1.98		<b>Shallow Concentrated Flow,</b> Short Grass Pasture Kv= 7.0 fps
9.5	175	Total			

**Subcatchment 3S: North Constructed Site**

Hydrograph

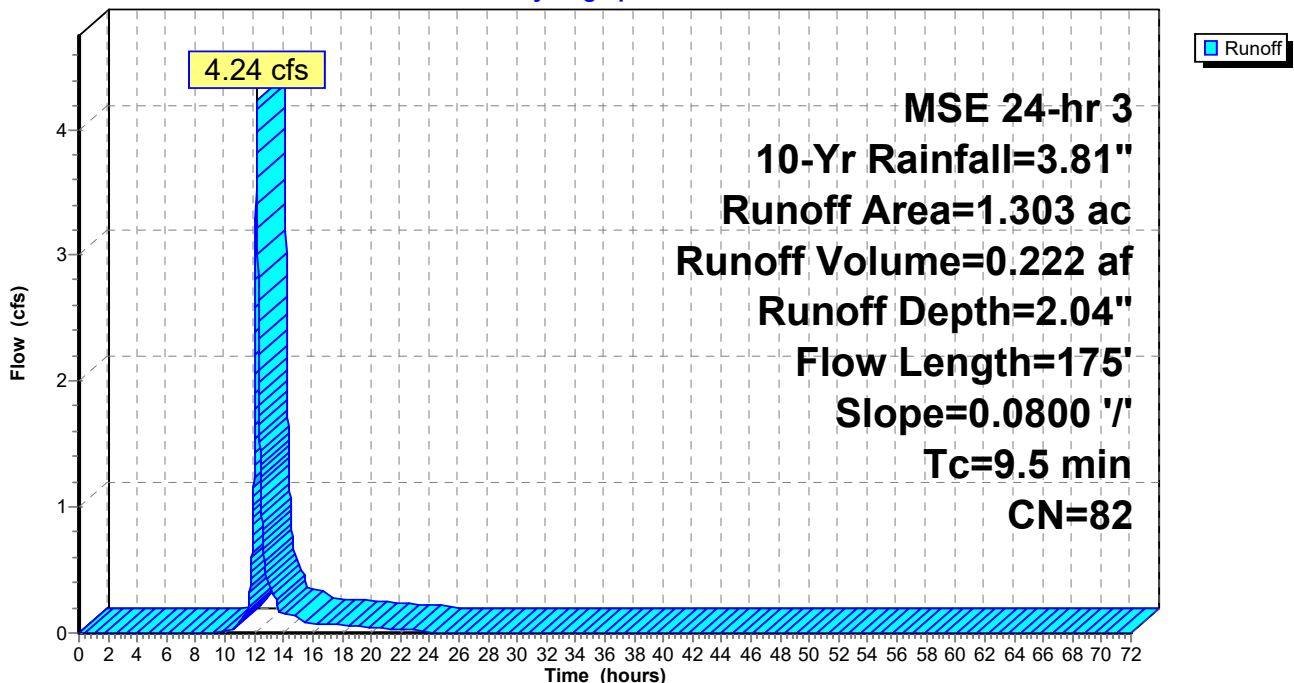

**Summary for Subcatchment 4aS: Offsite**

Runoff = 0.79 cfs @ 12.44 hrs, Volume= 0.074 af, Depth= 1.74"  
 Routed to Pond 1P : Wet Pond

Runoff by SCS TR-20 method, UH=SCS, Weighted-CN, Time Span= 0.00-72.00 hrs, dt= 0.01 hrs  
 MSE 24-hr 3 10-Yr Rainfall=3.81"

Area (ac)	CN	Description
* 0.509	78	
0.509		100.00% Pervious Area

Tc (min)	Length (feet)	Slope (ft/ft)	Velocity (ft/sec)	Capacity (cfs)	Description
29.4					Direct Entry,

**Subcatchment 4aS: Offsite**

Hydrograph

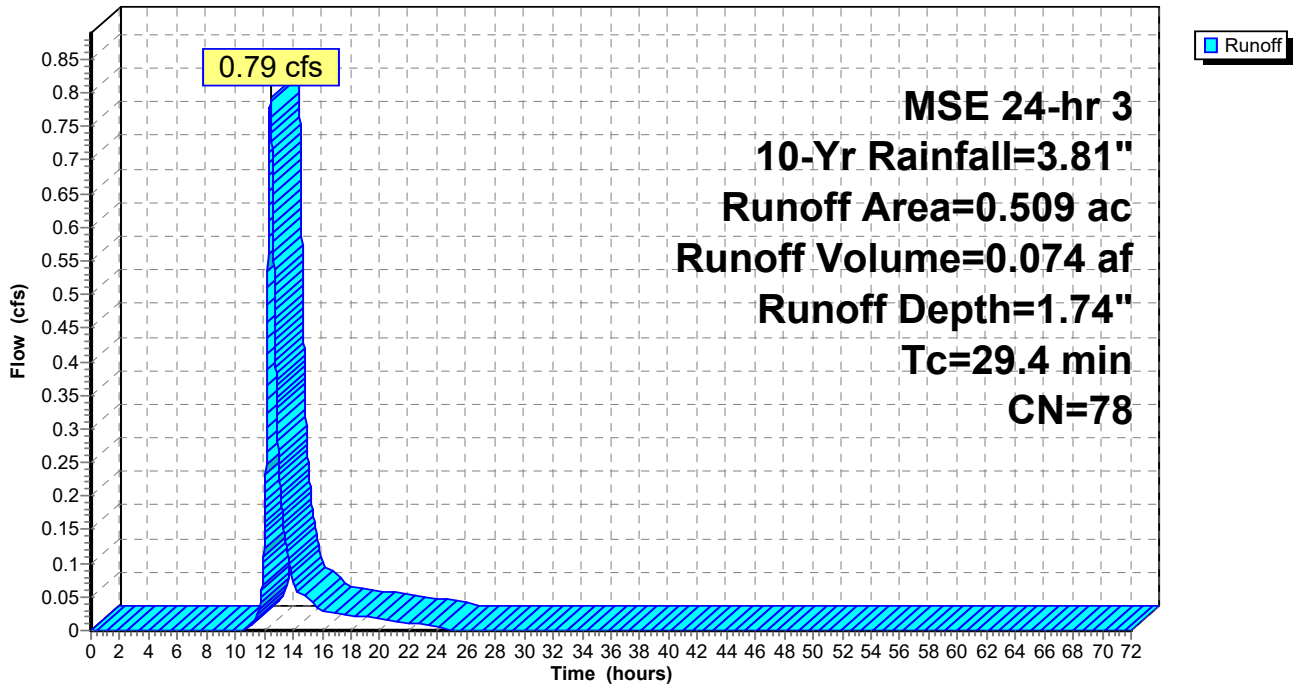

**Summary for Subcatchment 4bS: Offsite**

Runoff = 0.83 cfs @ 12.30 hrs, Volume= 0.063 af, Depth= 1.74"  
 Routed to Link 2L : Post-Development

Runoff by SCS TR-20 method, UH=SCS, Weighted-CN, Time Span= 0.00-72.00 hrs, dt= 0.01 hrs  
 MSE 24-hr 3 10-Yr Rainfall=3.81"

Area (ac)	CN	Description
* 0.432	78	
0.432		100.00% Pervious Area

Tc (min)	Length (feet)	Slope (ft/ft)	Velocity (ft/sec)	Capacity (cfs)	Description
20.3					Direct Entry,

**Subcatchment 4bS: Offsite**

Hydrograph

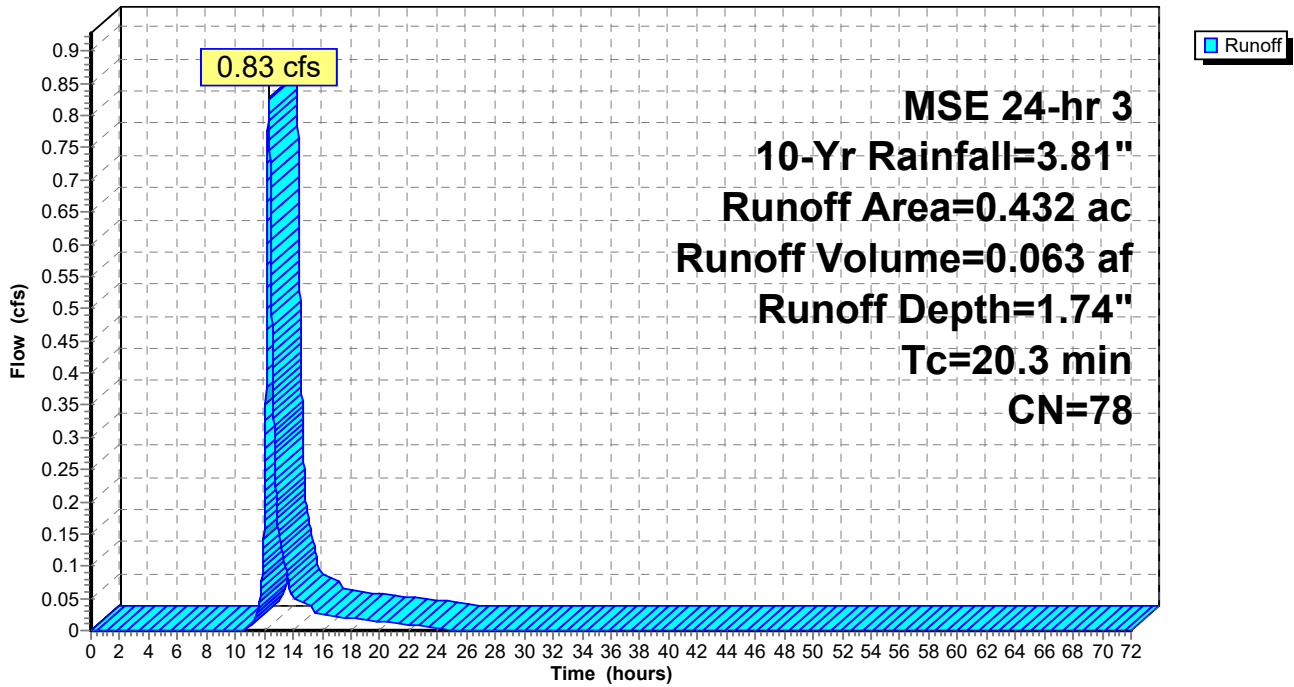

**Summary for Subcatchment 4S: South and East Constructed Site**

Runoff = 18.45 cfs @ 12.13 hrs, Volume= 0.864 af, Depth= 2.74"  
 Routed to Pond 1P : Wet Pond

Runoff by SCS TR-20 method, UH=SCS, Weighted-CN, Time Span= 0.00-72.00 hrs, dt= 0.01 hrs  
 MSE 24-hr 3 10-Yr Rainfall=3.81"

Area (ac)	CN	Description
* 2.143	98	Gravel Drive and Parking, HSG D
* 1.463	78	>75% Grass cover, Good, HSG D per ordinance
0.180	98	Water Surface, HSG D
3.786	90	Weighted Average
1.463		38.64% Pervious Area
2.323		61.36% Impervious Area

Tc (min)	Length (feet)	Slope (ft/ft)	Velocity (ft/sec)	Capacity (cfs)	Description
6.0					Direct Entry, Minimum

**Subcatchment 4S: South and East Constructed Site**

Hydrograph

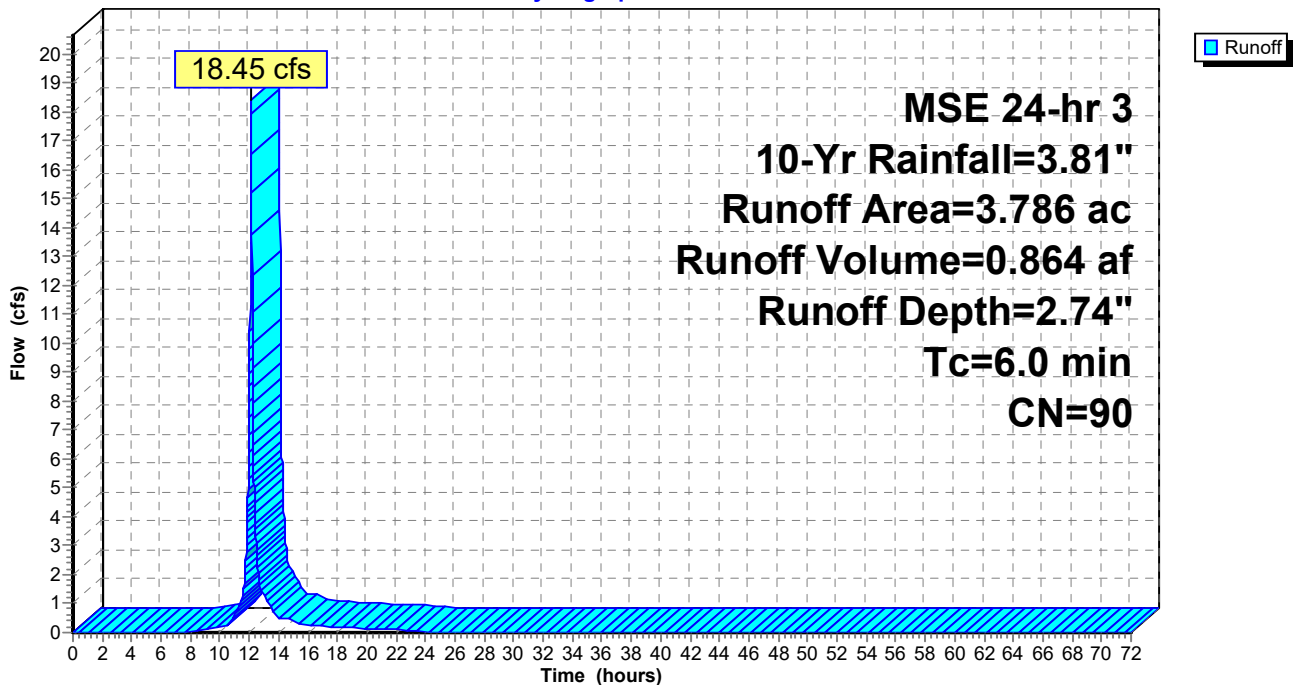

**Summary for Pond 1P: Wet Pond**

Inflow Area = 4.295 ac, 54.09% Impervious, Inflow Depth = 2.62" for 10-Yr event  
 Inflow = 18.71 cfs @ 12.13 hrs, Volume= 0.938 af  
 Outflow = 3.35 cfs @ 12.52 hrs, Volume= 0.938 af, Atten= 82%, Lag= 23.3 min  
 Primary = 3.35 cfs @ 12.52 hrs, Volume= 0.938 af  
 Routed to Link 2L : Post-Development  
 Secondary = 0.00 cfs @ 0.00 hrs, Volume= 0.000 af  
 Routed to Link 2L : Post-Development

Routing by Stor-Ind method, Time Span= 0.00-72.00 hrs, dt= 0.01 hrs  
 Peak Elev= 894.45' @ 12.52 hrs Surf.Area= 9,920 sf Storage= 19,771 cf

Plug-Flow detention time= 134.6 min calculated for 0.938 af (100% of inflow)  
 Center-of-Mass det. time= 134.4 min ( 922.8 - 788.3 )

Volume	Invert	Avail.Storage	Storage Description
#1	892.00'	37,068 cf	<b>Custom Stage Data (Prismatic)</b> Listed below (Recalc)
Elevation (feet)	Surf.Area (sq-ft)	Inc.Store (cubic-feet)	Cum.Store (cubic-feet)
892.00	6,098	0	0
893.00	7,827	6,963	6,963
894.00	9,243	8,535	15,498
895.00	10,760	10,002	25,499
896.00	12,378	11,569	37,068

Device	Routing	Invert	Outlet Devices
#1	Primary	892.00'	<b>24.0" Round Culvert</b> L= 24.0' RCP, groove end projecting, Ke= 0.200 Inlet / Outlet Invert= 892.00' / 891.52' S= 0.0200 1' Cc= 0.900 n= 0.013 Concrete pipe, bends & connections, Flow Area= 3.14 sf
#2	Device 1	892.00'	<b>7.0" Vert. Orifice/Grate</b> C= 0.600 Limited to weir flow at low heads
#3	Device 1	894.25'	<b>6.0' long x 0.5' breadth Top of Weir Plate</b> Head (feet) 0.20 0.40 0.60 0.80 1.00 Coef. (English) 2.80 2.92 3.08 3.30 3.32
#4	Secondary	895.15'	<b>20.0' long x 10.0' breadth Emergency Spillway</b> Head (feet) 0.20 0.40 0.60 0.80 1.00 1.20 1.40 1.60 Coef. (English) 2.49 2.56 2.70 2.69 2.68 2.69 2.67 2.64

**Primary OutFlow** Max=3.35 cfs @ 12.52 hrs HW=894.45' (Free Discharge)

- ↑ 1=Culvert (Passes 3.35 cfs of 21.08 cfs potential flow)
- ↑ 2=Orifice/Grate (Orifice Controls 1.89 cfs @ 7.07 fps)
- ↑ 3=Top of Weir Plate (Weir Controls 1.46 cfs @ 1.24 fps)

**Secondary OutFlow** Max=0.00 cfs @ 0.00 hrs HW=892.00' (Free Discharge)

- ↑ 4=Emergency Spillway ( Controls 0.00 cfs)



### Pond 1P: Wet Pond

#### Hydrograph

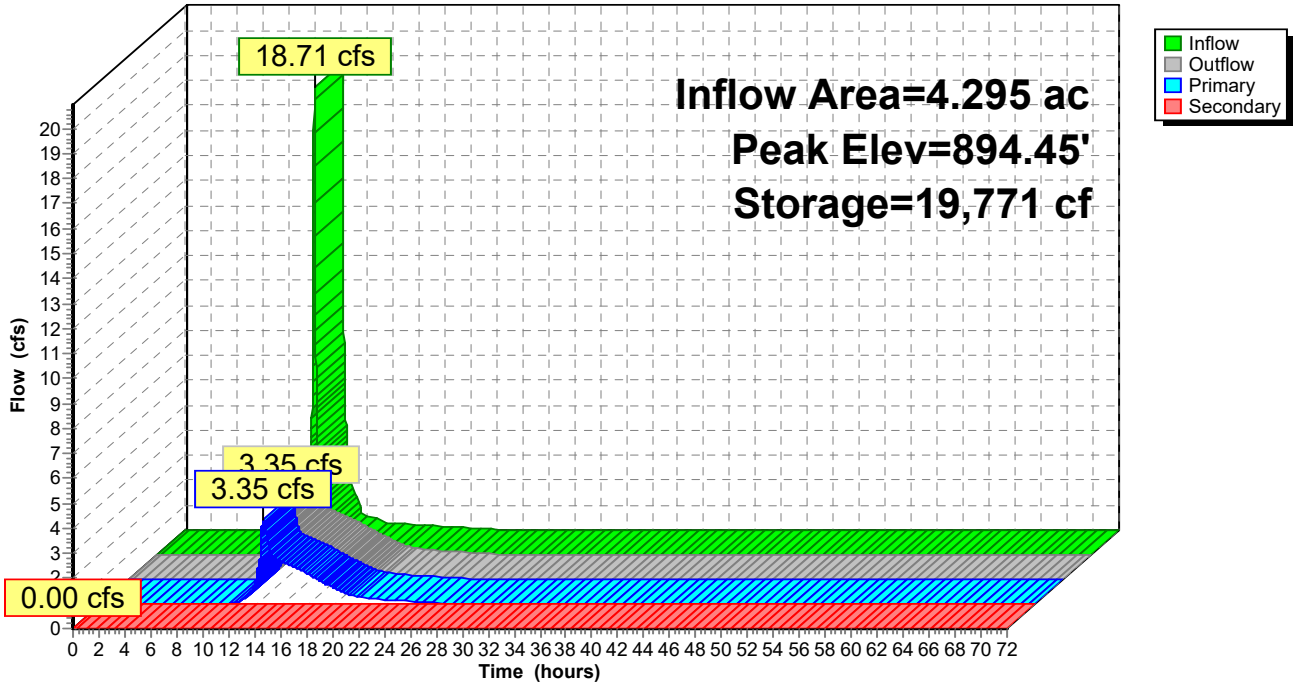

### Summary for Link 1L: Pre-Development

Inflow Area = 6.030 ac, 1.91% Impervious, Inflow Depth = 1.76" for 10-Yr event  
Inflow = 13.14 cfs @ 12.20 hrs, Volume= 0.884 af  
Primary = 13.14 cfs @ 12.20 hrs, Volume= 0.884 af, Atten= 0%, Lag= 0.0 min

Primary outflow = Inflow, Time Span= 0.00-72.00 hrs, dt= 0.01 hrs

### Link 1L: Pre-Development

Hydrograph

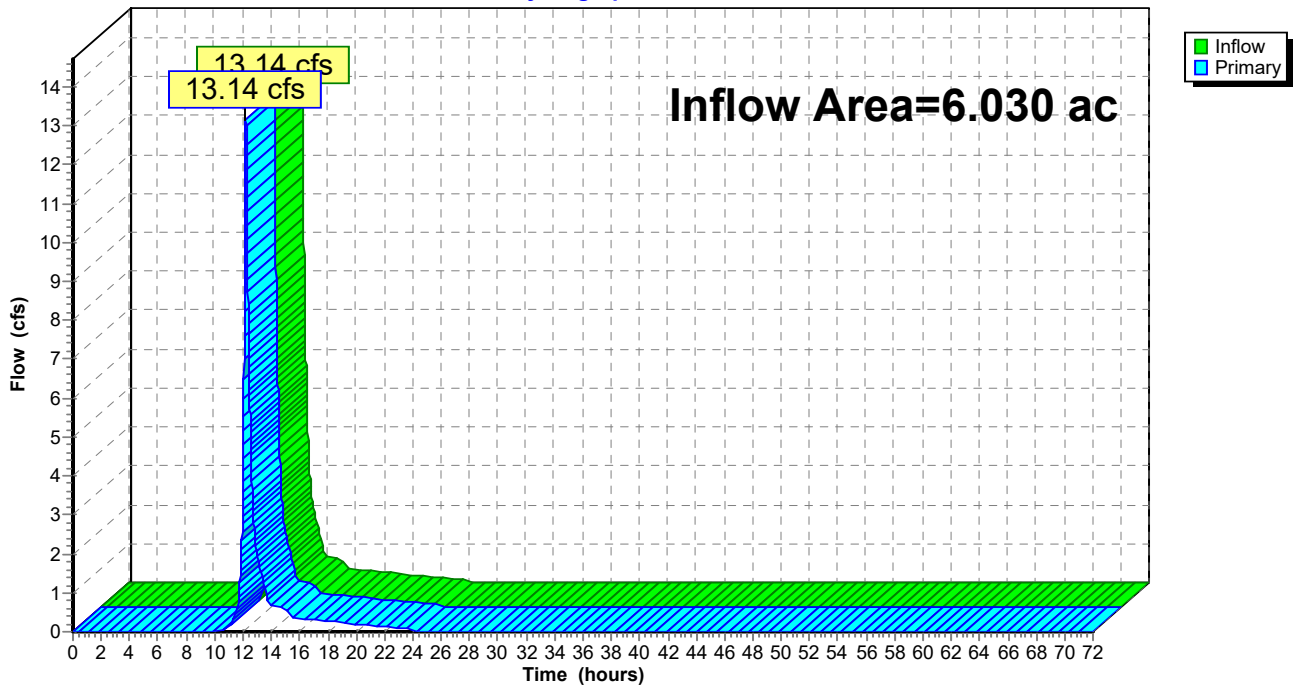

### Summary for Link 2L: Post-Development

Inflow Area = 6.030 ac, 43.35% Impervious, Inflow Depth = 2.43" for 10-Yr event  
Inflow = 6.45 cfs @ 12.18 hrs, Volume= 1.222 af  
Primary = 6.45 cfs @ 12.18 hrs, Volume= 1.222 af, Atten= 0%, Lag= 0.0 min

Primary outflow = Inflow, Time Span= 0.00-72.00 hrs, dt= 0.01 hrs

### Link 2L: Post-Development

Hydrograph

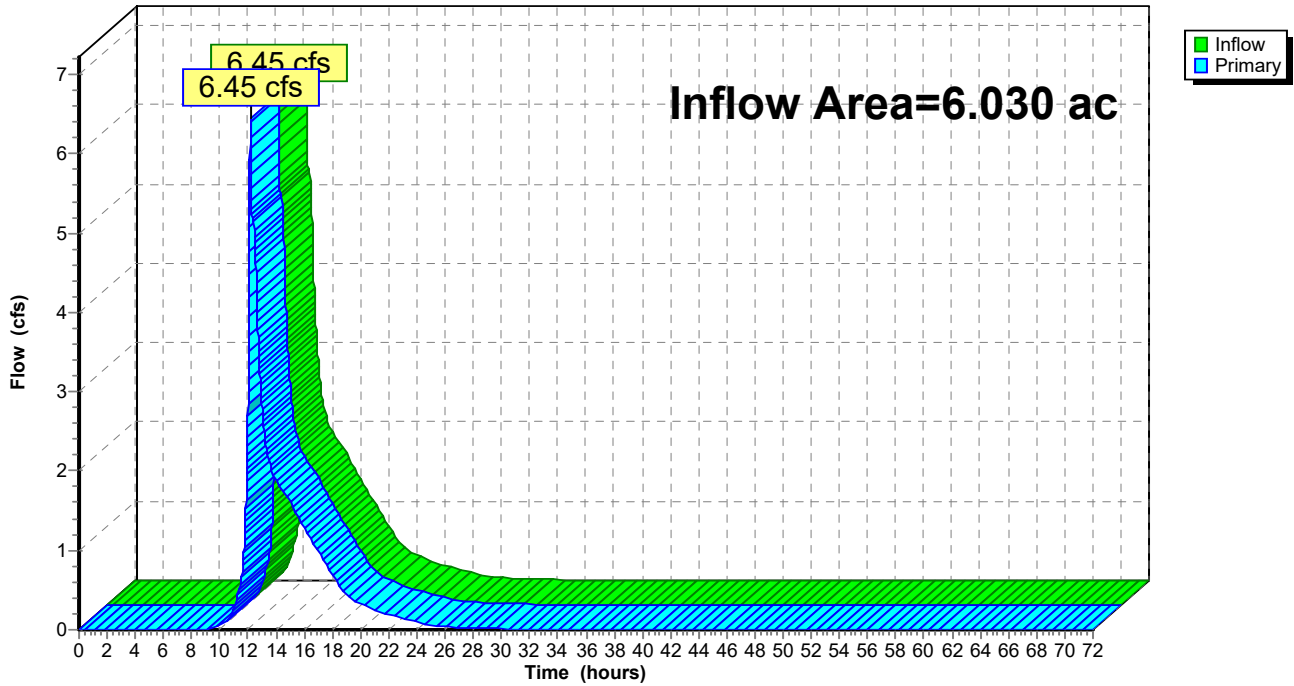

**Summary for Subcatchment 1S: North Original Site**

Runoff = 10.83 cfs @ 12.17 hrs, Volume= 0.572 af, Depth= 3.84"  
 Routed to Link 1L : Pre-Development

Runoff by SCS TR-20 method, UH=SCS, Weighted-CN, Time Span= 0.00-72.00 hrs, dt= 0.01 hrs  
 MSE 24-hr 3 100-Yr Rainfall=6.18"

Area (ac)	CN	Description
* 0.061	98	Paved asphalt drive, HSG D
* 0.017	98	Paved walks, HSG D
0.037	98	Roofs, HSG D
* 1.673	78	>75% Grass cover, Good, HSG D per ordinance
1.788	79	Weighted Average
1.673		93.57% Pervious Area
0.115		6.43% Impervious Area

Tc (min)	Length (feet)	Slope (ft/ft)	Velocity (ft/sec)	Capacity (cfs)	Description
8.9	100	0.0800	0.19		<b>Sheet Flow,</b> Grass: Dense n= 0.240 P2= 2.70"
0.6	75	0.0800	1.98		<b>Shallow Concentrated Flow,</b> Short Grass Pasture Kv= 7.0 fps
9.5	175	Total			

**Subcatchment 1S: North Original Site**

Hydrograph

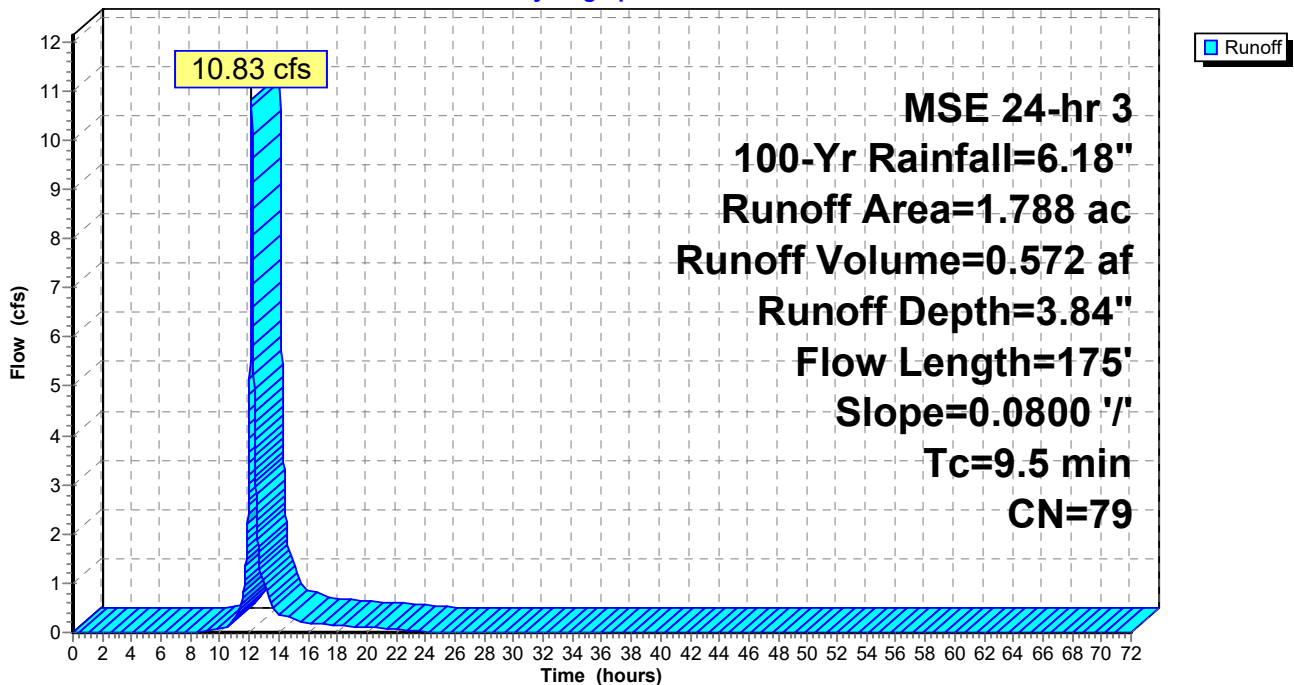

**Summary for Subcatchment 2aS: Offsite**

Runoff = 3.18 cfs @ 12.41 hrs, Volume= 0.293 af, Depth= 3.74"  
 Routed to Link 1L : Pre-Development

Runoff by SCS TR-20 method, UH=SCS, Weighted-CN, Time Span= 0.00-72.00 hrs, dt= 0.01 hrs  
 MSE 24-hr 3 100-Yr Rainfall=6.18"

Area (ac)	CN	Description
* 0.941	78	>75% Grass cover, Good, HSG D per ordinance
0.941		100.00% Pervious Area

Tc (min)	Length (feet)	Slope (ft/ft)	Velocity (ft/sec)	Capacity (cfs)	Description
29.4					Direct Entry,

**Subcatchment 2aS: Offsite**

Hydrograph

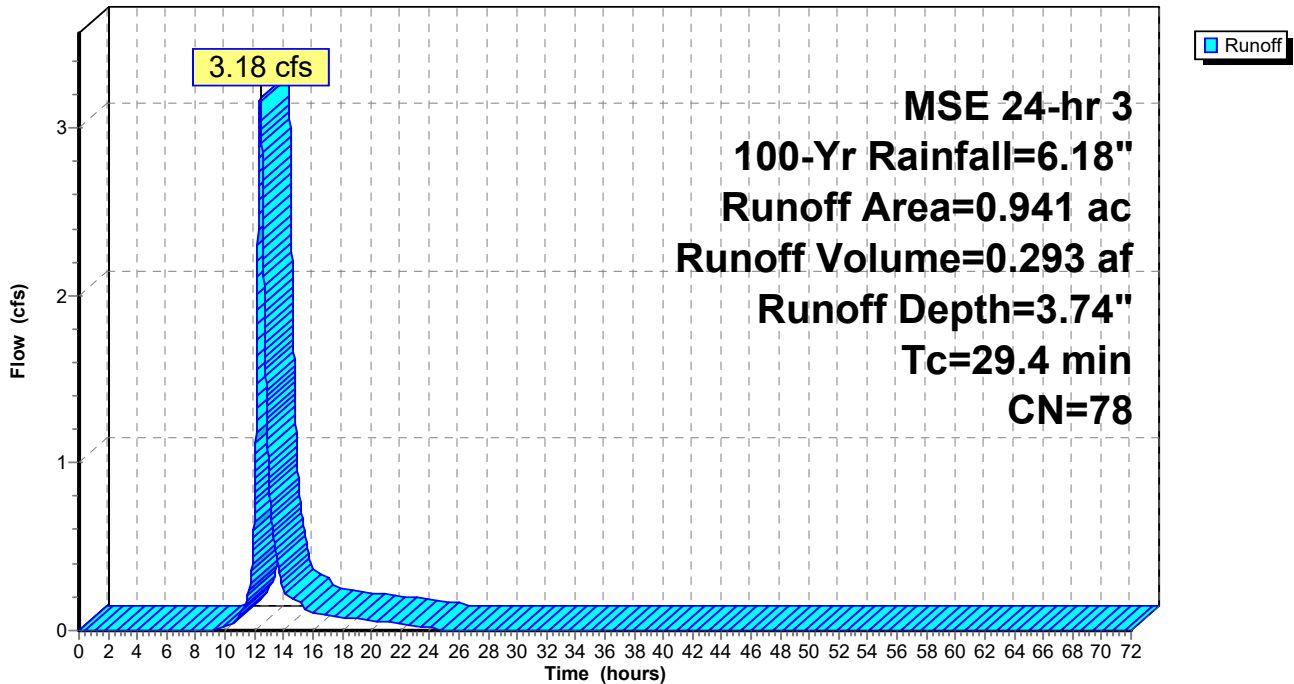

**Summary for Subcatchment 2S: South and East Original Site**

Runoff = 16.56 cfs @ 12.22 hrs, Volume= 1.028 af, Depth= 3.74"  
 Routed to Link 1L : Pre-Development

Runoff by SCS TR-20 method, UH=SCS, Weighted-CN, Time Span= 0.00-72.00 hrs, dt= 0.01 hrs  
 MSE 24-hr 3 100-Yr Rainfall=6.18"

Area (ac)	CN	Description
* 3.301	78	>75% Grass cover, Good, HSG D per ordinance
3.301		100.00% Pervious Area

Tc (min)	Length (feet)	Slope (ft/ft)	Velocity (ft/sec)	Capacity (cfs)	Description
10.0	100	0.0600	0.17		Sheet Flow, Grass: Dense n= 0.240 P2= 2.70"
3.8	475	0.0900	2.10		Shallow Concentrated Flow, Short Grass Pasture Kv= 7.0 fps
13.8	575	Total			

**Subcatchment 2S: South and East Original Site**

Hydrograph

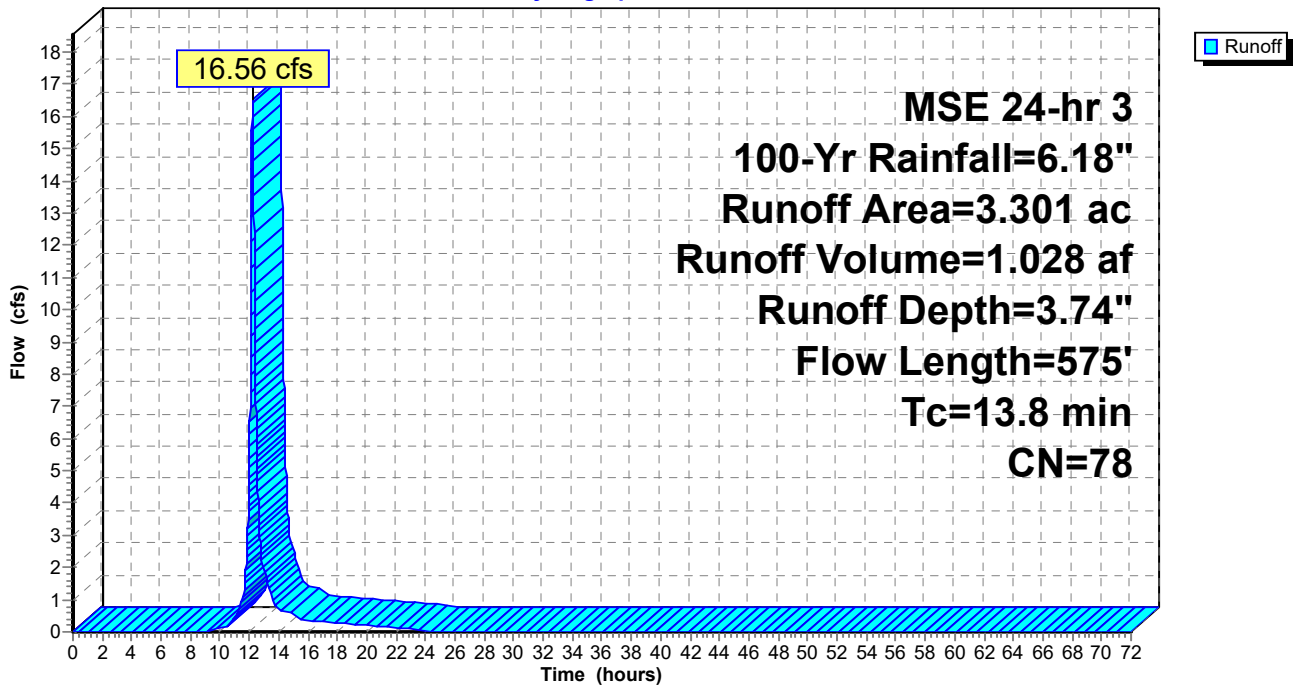

**Summary for Subcatchment 3S: North Constructed Site**

Runoff = 8.44 cfs @ 12.17 hrs, Volume= 0.451 af, Depth= 4.15"  
 Routed to Link 2L : Post-Development

Runoff by SCS TR-20 method, UH=SCS, Weighted-CN, Time Span= 0.00-72.00 hrs, dt= 0.01 hrs  
 MSE 24-hr 3 100-Yr Rainfall=6.18"

Area (ac)	CN	Description
* 0.061	98	Paved asphalt drive, HSG D
* 0.017	98	Paved walks, HSG D
0.037	98	Roofs, HSG D
* 0.176	98	Gravel Drive, HSG D
* 1.012	78	>75% Grass cover, Good, HSG D per ordinance
1.303	82	Weighted Average
1.012		77.67% Pervious Area
0.291		22.33% Impervious Area

Tc (min)	Length (feet)	Slope (ft/ft)	Velocity (ft/sec)	Capacity (cfs)	Description
8.9	100	0.0800	0.19		<b>Sheet Flow,</b> Grass: Dense n= 0.240 P2= 2.70"
0.6	75	0.0800	1.98		<b>Shallow Concentrated Flow,</b> Short Grass Pasture Kv= 7.0 fps
9.5	175	Total			

**Subcatchment 3S: North Constructed Site**

Hydrograph

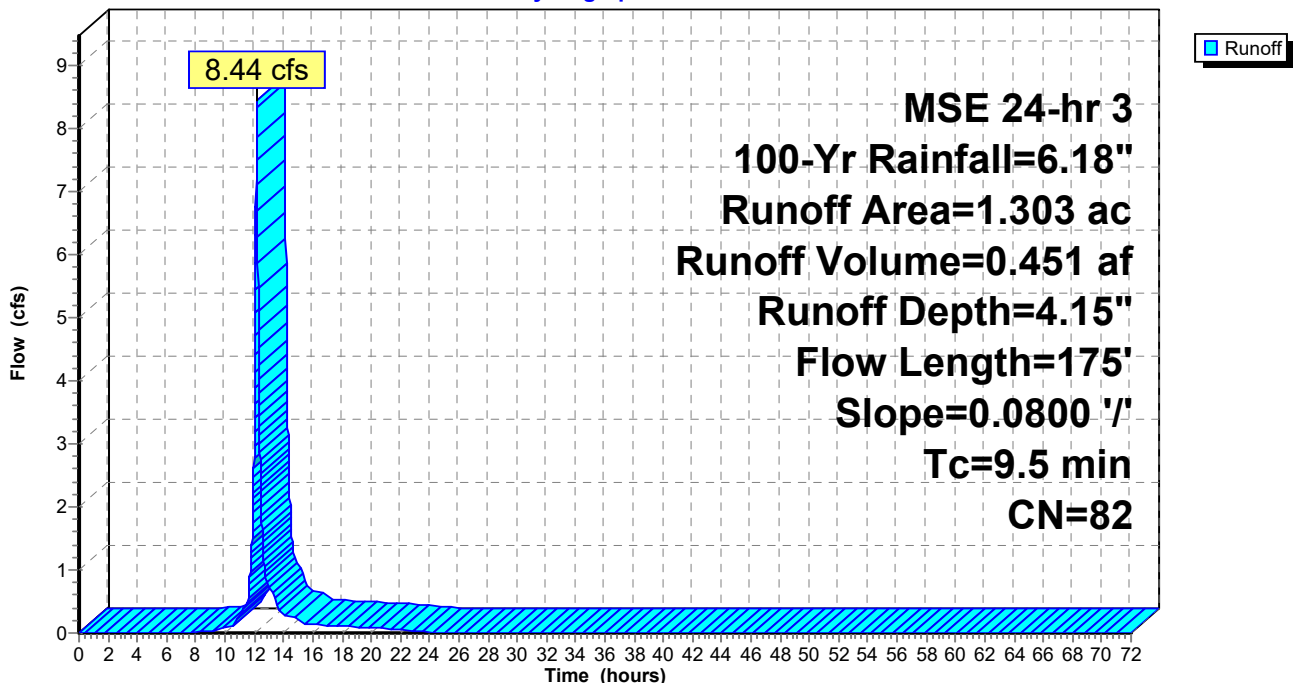

**Summary for Subcatchment 4aS: Offsite**

Runoff = 1.72 cfs @ 12.41 hrs, Volume= 0.159 af, Depth= 3.74"  
 Routed to Pond 1P : Wet Pond

Runoff by SCS TR-20 method, UH=SCS, Weighted-CN, Time Span= 0.00-72.00 hrs, dt= 0.01 hrs  
 MSE 24-hr 3 100-Yr Rainfall=6.18"

Area (ac)	CN	Description
* 0.509	78	
0.509		100.00% Pervious Area

Tc (min)	Length (feet)	Slope (ft/ft)	Velocity (ft/sec)	Capacity (cfs)	Description
29.4					Direct Entry,

**Subcatchment 4aS: Offsite**

Hydrograph

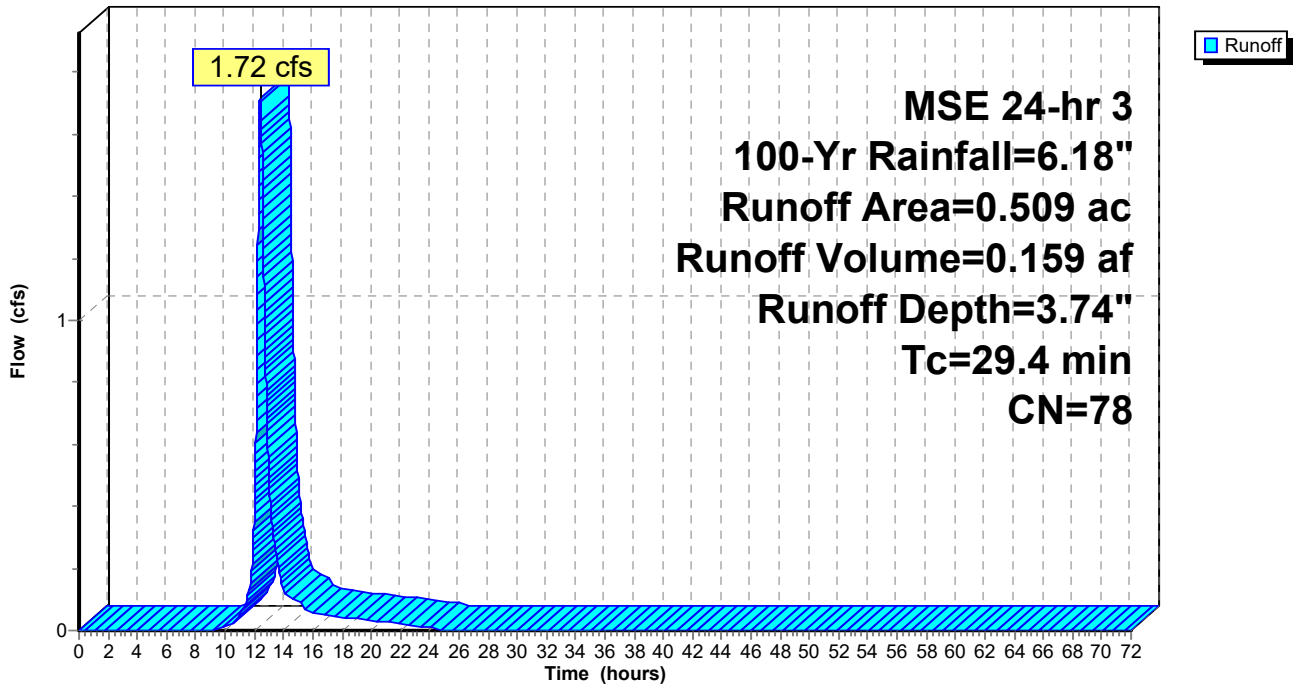



**Summary for Subcatchment 4bS: Offsite**

Runoff = 1.80 cfs @ 12.29 hrs, Volume= 0.135 af, Depth= 3.74"  
 Routed to Link 2L : Post-Development

Runoff by SCS TR-20 method, UH=SCS, Weighted-CN, Time Span= 0.00-72.00 hrs, dt= 0.01 hrs  
 MSE 24-hr 3 100-Yr Rainfall=6.18"

Area (ac)	CN	Description
* 0.432	78	
0.432		100.00% Pervious Area

Tc (min)	Length (feet)	Slope (ft/ft)	Velocity (ft/sec)	Capacity (cfs)	Description
20.3					Direct Entry,

**Subcatchment 4bS: Offsite**

Hydrograph

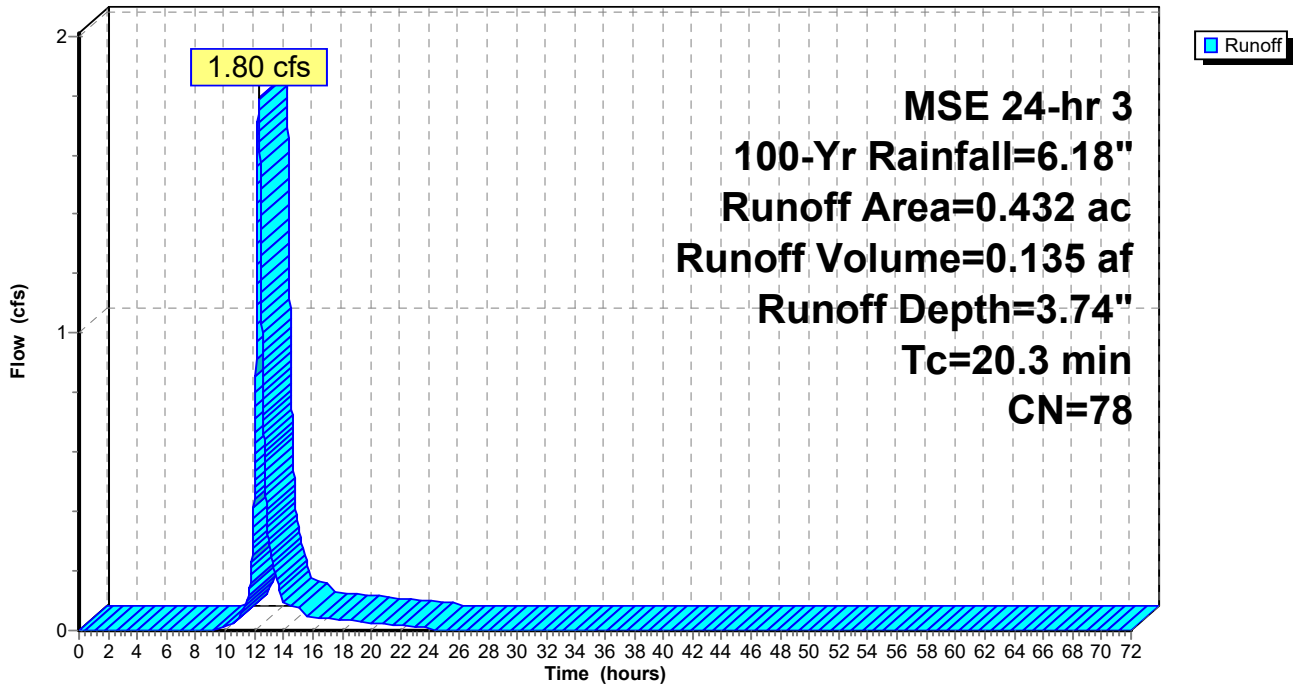

**Summary for Subcatchment 4S: South and East Constructed Site**

Runoff = 32.53 cfs @ 12.13 hrs, Volume= 1.584 af, Depth= 5.02"  
 Routed to Pond 1P : Wet Pond

Runoff by SCS TR-20 method, UH=SCS, Weighted-CN, Time Span= 0.00-72.00 hrs, dt= 0.01 hrs  
 MSE 24-hr 3 100-Yr Rainfall=6.18"

Area (ac)	CN	Description
* 2.143	98	Gravel Drive and Parking, HSG D
* 1.463	78	>75% Grass cover, Good, HSG D per ordinance
0.180	98	Water Surface, HSG D
3.786	90	Weighted Average
1.463		38.64% Pervious Area
2.323		61.36% Impervious Area

Tc (min)	Length (feet)	Slope (ft/ft)	Velocity (ft/sec)	Capacity (cfs)	Description
6.0					Direct Entry, Minimum

**Subcatchment 4S: South and East Constructed Site**

Hydrograph

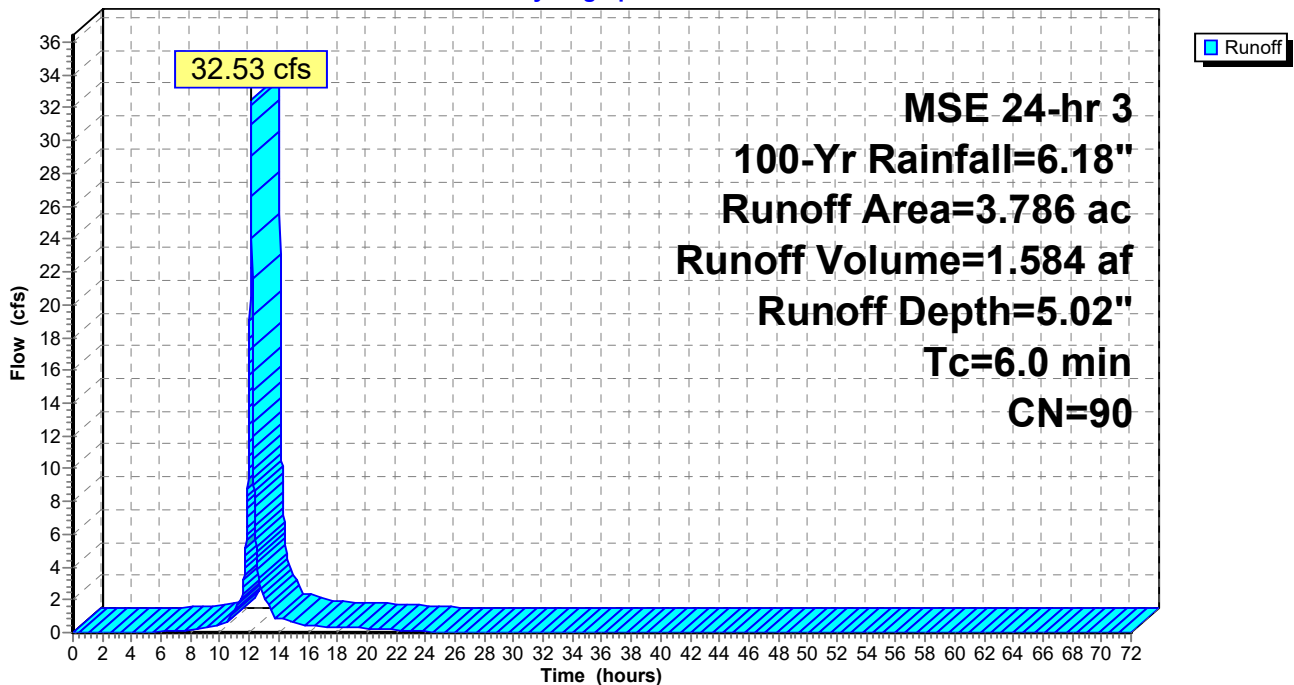

**Summary for Pond 1P: Wet Pond**

Inflow Area = 4.295 ac, 54.09% Impervious, Inflow Depth = 4.87" for 100-Yr event  
 Inflow = 33.21 cfs @ 12.13 hrs, Volume= 1.743 af  
 Outflow = 18.74 cfs @ 12.21 hrs, Volume= 1.743 af, Atten= 44%, Lag= 4.7 min  
 Primary = 18.74 cfs @ 12.21 hrs, Volume= 1.743 af  
 Routed to Link 2L : Post-Development  
 Secondary = 0.00 cfs @ 0.00 hrs, Volume= 0.000 af  
 Routed to Link 2L : Post-Development

Routing by Stor-Ind method, Time Span= 0.00-72.00 hrs, dt= 0.01 hrs  
 Peak Elev= 895.14' @ 12.21 hrs Surf.Area= 10,981 sf Storage= 26,981 cf

Plug-Flow detention time= 95.6 min calculated for 1.742 af (100% of inflow)  
 Center-of-Mass det. time= 95.8 min ( 872.5 - 776.7 )

Volume	Invert	Avail.Storage	Storage Description
#1	892.00'	37,068 cf	<b>Custom Stage Data (Prismatic)</b> Listed below (Recalc)
Elevation (feet)	Surf.Area (sq-ft)	Inc.Store (cubic-feet)	Cum.Store (cubic-feet)
892.00	6,098	0	0
893.00	7,827	6,963	6,963
894.00	9,243	8,535	15,498
895.00	10,760	10,002	25,499
896.00	12,378	11,569	37,068

Device	Routing	Invert	Outlet Devices
#1	Primary	892.00'	<b>24.0" Round Culvert</b> L= 24.0' RCP, groove end projecting, Ke= 0.200 Inlet / Outlet Invert= 892.00' / 891.52' S= 0.0200 1' Cc= 0.900 n= 0.013 Concrete pipe, bends & connections, Flow Area= 3.14 sf
#2	Device 1	892.00'	<b>7.0" Vert. Orifice/Grate</b> C= 0.600 Limited to weir flow at low heads
#3	Device 1	894.25'	<b>6.0' long x 0.5' breadth Top of Weir Plate</b> Head (feet) 0.20 0.40 0.60 0.80 1.00 Coef. (English) 2.80 2.92 3.08 3.30 3.32
#4	Secondary	895.15'	<b>20.0' long x 10.0' breadth Emergency Spillway</b> Head (feet) 0.20 0.40 0.60 0.80 1.00 1.20 1.40 1.60 Coef. (English) 2.49 2.56 2.70 2.69 2.68 2.69 2.67 2.64

**Primary OutFlow** Max=18.73 cfs @ 12.21 hrs HW=895.14' (Free Discharge)

- ↑ 1=Culvert (Passes 18.73 cfs of 26.18 cfs potential flow)
- ↑ 2=Orifice/Grate (Orifice Controls 2.17 cfs @ 8.12 fps)
- ↑ 3=Top of Weir Plate (Weir Controls 16.56 cfs @ 3.11 fps)

**Secondary OutFlow** Max=0.00 cfs @ 0.00 hrs HW=892.00' (Free Discharge)

- ↑ 4=Emergency Spillway ( Controls 0.00 cfs)

### Pond 1P: Wet Pond

#### Hydrograph

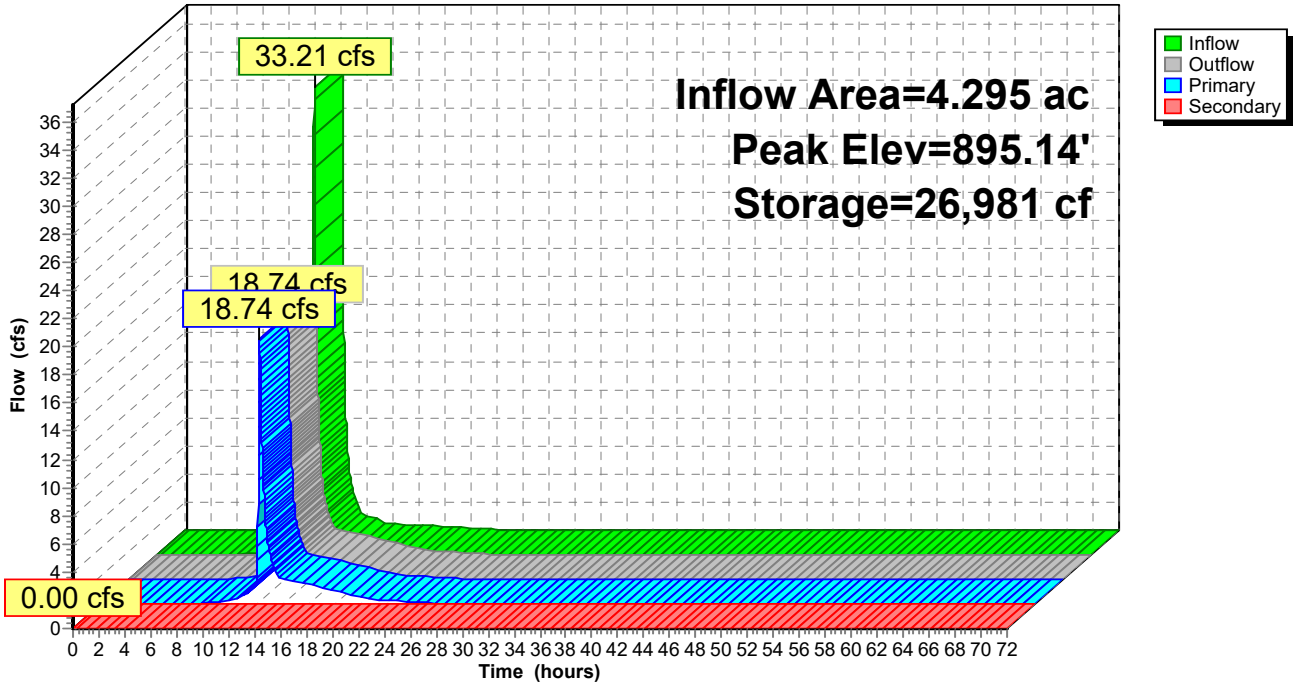

### Summary for Link 1L: Pre-Development

Inflow Area = 6.030 ac, 1.91% Impervious, Inflow Depth = 3.77" for 100-Yr event  
Inflow = 28.25 cfs @ 12.19 hrs, Volume= 1.894 af  
Primary = 28.25 cfs @ 12.19 hrs, Volume= 1.894 af, Atten= 0%, Lag= 0.0 min

Primary outflow = Inflow, Time Span= 0.00-72.00 hrs, dt= 0.01 hrs

### Link 1L: Pre-Development

Hydrograph

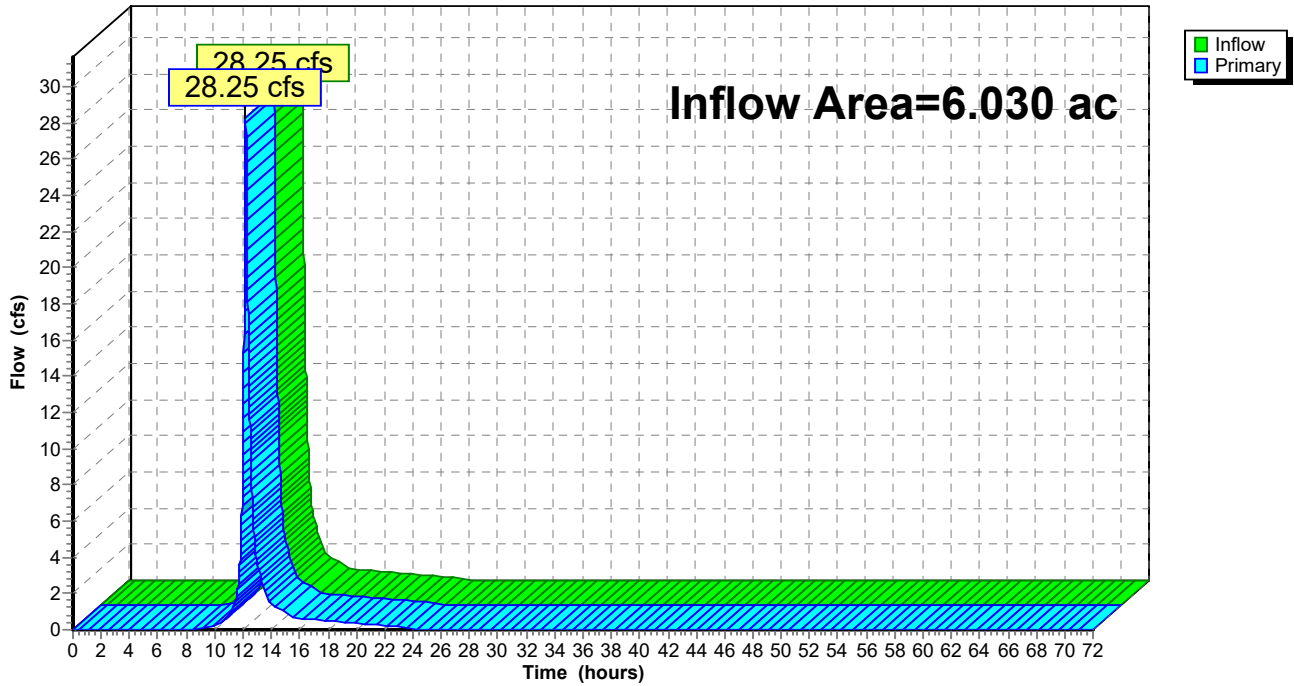

### Summary for Link 2L: Post-Development

Inflow Area = 6.030 ac, 43.35% Impervious, Inflow Depth = 4.63" for 100-Yr event  
Inflow = 27.98 cfs @ 12.20 hrs, Volume= 2.328 af  
Primary = 27.98 cfs @ 12.20 hrs, Volume= 2.328 af, Atten= 0%, Lag= 0.0 min

Primary outflow = Inflow, Time Span= 0.00-72.00 hrs, dt= 0.01 hrs

### Link 2L: Post-Development

Hydrograph

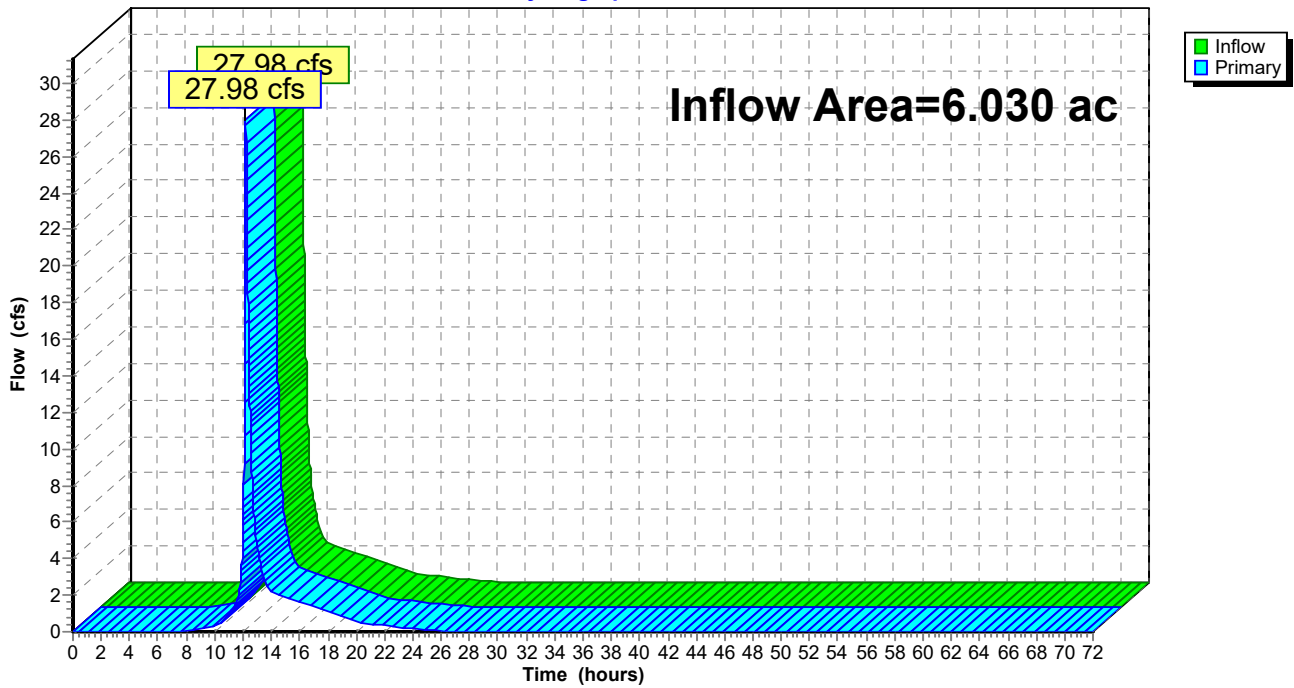

# Appendix 3

## WinSLAMM Input/Output

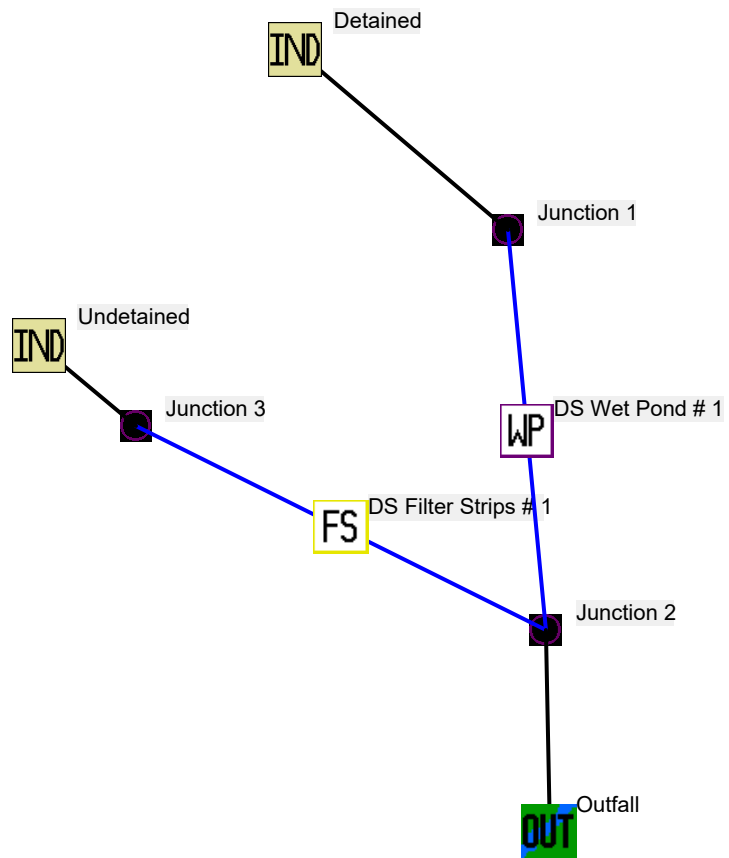



Data file name: S:\Design & Construction Services\Prairie Philip\SWMP\WinSLAMM\2022-08-05 Prairie Phillip.mdb

WinSLAMM Version 10.4.1

Rain file name: C:\WinSLAMM Files\Rain Files\WI Milwaukee 69.RAN

Particulate Solids Concentration file name: C:\WinSLAMM Files\w10.1 WI\_AVG01.pscx

Runoff Coefficient file name: C:\WinSLAMM Files\WI\_SL06 Dec06.rsvx

Residential Street Delivery file name: C:\WinSLAMM Files\WI\_Com Inst Indust Dec06.std

Institutional Street Delivery file name: C:\WinSLAMM Files\WI\_Com Inst Indust Dec06.std

Commercial Street Delivery file name: C:\WinSLAMM Files\WI\_Com Inst Indust Dec06.std

Industrial Street Delivery file name: C:\WinSLAMM Files\WI\_Com Inst Indust Dec06.std

Other Urban Street Delivery file name: C:\WinSLAMM Files\WI\_Com Inst Indust Dec06.std

Freeway Street Delivery file name: C:\WinSLAMM Files\WI\_Com Inst Indust Dec06.std

Apply Street Delivery Files to Adjust the After Event Load Street Dirt Mass Balance: False

Pollutant Relative Concentration file name: C:\WinSLAMM Files\WI\_GEO03.ppdx

Source Area PSD and Peak to Average Flow Ratio File: C:\WinSLAMM Files\NURP Source Area PSD Files.csv

Cost Data file name:

If Other Device Pollutant Load Reduction Values = 1, Off-site Pollutant Loads are Removed from Pollutant Load % Reduction calculations

Seed for random number generator: -42

Study period starting date: 03/28/69 Study period ending date: 12/06/69

Date: 08-05-2022 Time: 15:24:34

Site information:

LU# 1 - Industrial: 3S Total area (ac): 1.303

1 - Roofs 1: 0.037 ac. Pitched Disconnected Normal Clayey Low Density PSD File: C:\WinSLAMM Files\NURP.cpz

25 - Driveways 1: 0.061 ac. Disconnected Normal Silty PSD File: C:\WinSLAMM Files\NURP.cpz

26 - Driveways 2: 0.176 ac. Disconnected Normal Clayey Low Density PSD File: C:\WinSLAMM Files\NURP.cpz

31 - Sidewalks 1: 0.017 ac. Disconnected Normal Clayey Low Density PSD File: C:\WinSLAMM Files\NURP.cpz

45 - Large Landscaped Areas 1: 1.012 ac. Normal Clayey Low Density PSD File: C:\WinSLAMM Files\NURP.cpz

LU# 2 - Industrial: 4S Total area (ac): 3.786

13 - Paved Parking 1: 2.143 ac. Disconnected Normal Clayey Low Density PSD File: C:\WinSLAMM Files\NURP.cpz

45 - Large Landscaped Areas 1: 1.463 ac. Normal Clayey Low Density PSD File: C:\WinSLAMM Files\NURP.cpz

70 - Water Body Areas: 0.180 ac. PSD File:

LU# 3 - Industrial: 4aS Total area (ac): 0.509

45 - Large Landscaped Areas 1: 0.509 ac. Normal Clayey Low Density PSD File: C:\WinSLAMM Files\NURP.cpz

LU# 4 - Industrial: 4bS Total area (ac): 0.432

45 - Large Landscaped Areas 1: 0.432 ac. Normal Clayey Low Density PSD File: C:\WinSLAMM Files\NURP.cpz

Control Practice 1: Wet Detention Pond CP# 1 (DS) - DS Wet Pond # 1

Particle Size Distribution file name: Not needed - calculated by program

Initial stage elevation (ft): 5

Peak to Average Flow Ratio: 3.8

Maximum flow allowed into pond (cfs): No maximum value entered

Outlet Characteristics:

Outlet type: Orifice 1

1. Orifice diameter (ft): 0.58

2. Number of orifices: 1

3. Invert elevation above datum (ft): 5

Outlet type: Broad Crested Weir

1. Weir crest length (ft): 20

2. Weir crest width (ft): 10

3. Height from datum to bottom of weir opening: 8.55

Pond stage and surface area

Entry Number	Stage (ft)	Pond Area (acres)	Natural Seepage (in/hr)	Other Outflow (cfs)
0	0.00	0.0000	0.00	0.00
1	0.01	0.0119	0.00	0.00
2	1.00	0.0213	0.00	0.00
3	2.00	0.0343	0.00	0.00
4	3.00	0.0510	0.00	0.00
5	4.00	0.0712	0.00	0.00
6	5.00	0.1400	0.00	0.00
7	6.00	0.1800	0.00	0.00
8	7.00	0.2120	0.00	0.00
9	8.00	0.2470	0.00	0.00
10	9.00	0.2840	0.00	0.00

Control Practice 2: Filter Strip CP# 1 (DS) - DS Filter Strips # 1

Total drainage area (acres)= 1.303

Fraction of drainage area served by filter strips (ac) = 1.00

Total filter strip width (ft) = 655.0

Effective flow length (ft) = 18

Infiltration rate (in/hr)= 0.010

Typical longitudinal slope (ft.H/ft.V) = 0.080

Typical grass height (in) = 3.0

Swale retardance factor = C

Use stochastic analysis to determine infiltration rate: False

Infiltration rate coefficient of variation (COV) = 0.00

Particle size distribution file name: Not needed - calculated by program

Surface Clogging Load (lbs/sf) = 3.50

Data file name: S:\Design & Construction Services\Prairie Philip\SWMP\WinSLAMM\2022-08-05 Prairie Phillip.mdb

WinSLAMM Version 10.4.1

Data file name: S:\Design & Construction Services\Prairie Philip\SWMP\WinSLAMM\2022-08-05 Prairie Phillip.mdb  
WinSLAMM Version 10.4.1

Rain file name: C:\WinSLAMM Files\Rain Files\WI Milwaukee 69.RAN  
Particulate Solids Concentration file name: C:\WinSLAMM Files\v10.1 WI\_AVG01.pscx  
Runoff Coefficient file name: C:\WinSLAMM Files\WI\_SL06 Dec06.rsvx  
Pollutant Relative Concentration file name: C:\WinSLAMM Files\WI\_GEO03.ppdX  
Residential Street Delivery file name: C:\WinSLAMM Files\WI\_Com Inst Indust Dec06.std  
Institutional Street Delivery file name: C:\WinSLAMM Files\WI\_Com Inst Indust Dec06.std  
Commercial Street Delivery file name: C:\WinSLAMM Files\WI\_Com Inst Indust Dec06.std  
Industrial Street Delivery file name: C:\WinSLAMM Files\WI\_Com Inst Indust Dec06.std  
Other Urban Street Delivery file name: C:\WinSLAMM Files\WI\_Com Inst Indust Dec06.std  
Freeway Street Delivery file name: C:\WinSLAMM Files\WI\_Com Inst Indust Dec06.std  
Apply Street Delivery Files to Adjust the After Event Load Street Dirt Mass Balance: False  
Source Area PSD and Peak to Average Flow Ratio File: C:\WinSLAMM Files\NURP Source Area PSD Files.csv  
Cost Data file name:

If Other Device Pollutant Load Reduction Values = 1, Off-site Pollutant Loads are Removed from Pollutant Load % Reduction calculations

Seed for random number generator: -42  
Study period starting date: 03/28/69 Study period ending date: 12/06/69  
Model Run Start Date: 03/28/69 Model Run End Date: 12/06/69  
Date of run: 08-05-2022 Time of run: 15:26:31  
Total Area Modeled (acres): 6.030  
Years in Model Run: 0.67

	Runoff Volume (cu ft)	Percent Runoff Volume Reduction	Particulate Solids Conc. (mg/L)	Particulate Solids Yield (lbs)	Percent Particulate Solids Reduction
Total of all Land Uses without Controls:	62849	-	135.7	532.6	-
Outfall Total with Controls:	60546	3.66%	27.66	104.6	80.36%
Annualized Total After Outfall Controls:	90943			157.0	

Rain file name: C:\WinSLAMM Files\Rain Files\WI Milwaukee 69.RAN  
 Particulate Solids Concentration file name: C:\WinSLAMM Files\10.1 WI\_AVG01.pscx  
 Runoff Coefficient file name: C:\WinSLAMM Files\WI\_SL06 Dec06.rsvx  
 Residential Street Delivery file name: C:\WinSLAMM Files\WI\_Com Inst Indust Dec06.std  
 Institutional Street Delivery file name: C:\WinSLAMM Files\WI\_Com Inst Indust Dec06.std  
 Commercial Street Delivery file name: C:\WinSLAMM Files\WI\_Com Inst Indust Dec06.std  
 Industrial Street Delivery file name: C:\WinSLAMM Files\WI\_Com Inst Indust Dec06.std  
 Other Urban Street Delivery file name: C:\WinSLAMM Files\WI\_Com Inst Indust Dec06.std  
 Freeway Street Delivery file name: C:\WinSLAMM Files\WI\_Com Inst Indust Dec06.std  
 Apply Street Delivery Files to Adjust the After Event Load Street Dirt Mass Balance: False  
 Pollutant Relative Concentration file name: C:\WinSLAMM Files\WI\_GEO03.ppdx  
 Source Area PSD and Peak to Average Flow Ratio File: C:\WinSLAMM Files\NURP Source Area PSD Files.csv  
 Cost Data file name:  
 If Other Device Pollutant Load Reduction Values = 1, Off-site Pollutant Loads are Removed from Pollutant Load % Reduction calculations  
 Seed for random number generator: -42  
 Study period starting date: 03/28/69 Study period ending date: 12/06/69  
 Date: 08-05-2022 Time: 15:25:14  
 Site information:

LU# 1 - Industrial: 3S Total area (ac): 1.303  
 1 - Roofs 1: 0.037 ac. Pitched Disconnected Normal Clayey Low Density PSD File: C:\WinSLAMM Files\NURP.cpz  
 25 - Driveways 1: 0.061 ac. Disconnected Normal Silty PSD File: C:\WinSLAMM Files\NURP.cpz  
 26 - Driveways 2: 0.176 ac. Disconnected Normal Clayey Low Density PSD File: C:\WinSLAMM Files\NURP.cpz  
 31 - Sidewalks 1: 0.017 ac. Disconnected Normal Clayey Low Density PSD File: C:\WinSLAMM Files\NURP.cpz  
 45 - Large Landscaped Areas 1: 1.012 ac. Normal Clayey Low Density PSD File: C:\WinSLAMM Files\NURP.cpz

LU# 2 - Industrial: 4S Total area (ac): 3.786  
 13 - Paved Parking 1: 2.143 ac. Disconnected Normal Clayey Low Density PSD File: C:\WinSLAMM Files\NURP.cpz  
 45 - Large Landscaped Areas 1: 1.463 ac. Normal Clayey Low Density PSD File: C:\WinSLAMM Files\NURP.cpz  
 70 - Water Body Areas: 0.180 ac. PSD File:

LU# 3 - Industrial: 4aS Total area (ac): 0.509  
 45 - Large Landscaped Areas 1: 0.509 ac. Normal Clayey Low Density PSD File: C:\WinSLAMM Files\NURP.cpz

LU# 4 - Industrial: 4bS Total area (ac): 0.432  
 45 - Large Landscaped Areas 1: 0.432 ac. Normal Clayey Low Density PSD File: C:\WinSLAMM Files\NURP.cpz

Control Practice 1: Wet Detention Pond CP# 1 (DS) - DS Wet Pond # 1  
 Particle Size Distribution file name: Not needed - calculated by program  
 Initial stage elevation (ft): 5  
 Peak to Average Flow Ratio: 3.8  
 Maximum flow allowed into pond (cfs): No maximum value entered  
 Outlet Characteristics:  
 Outlet type: Orifice 1  
 1. Orifice diameter (ft): 0.58  
 2. Number of orifices: 1  
 3. Invert elevation above datum (ft): 5  
 Outlet type: Broad Crested Weir  
 1. Weir crest length (ft): 20  
 2. Weir crest width (ft): 10  
 3. Height from datum to bottom of weir opening: 8.55

Pond stage and surface area

Entry Number	Stage (ft)	Pond Area (acres)	Natural Seepage (in/hr)	Other Outflow (cfs)
0	0.00	0.0000	0.00	0.00
1	0.01	0.0119	0.00	0.00
2	1.00	0.0213	0.00	0.00
3	2.00	0.0343	0.00	0.00
4	3.00	0.0510	0.00	0.00
5	4.00	0.0712	0.00	0.00
6	5.00	0.1400	0.00	0.00
7	6.00	0.1800	0.00	0.00
8	7.00	0.2120	0.00	0.00
9	8.00	0.2470	0.00	0.00
10	9.00	0.2840	0.00	0.00

Control Practice 2: Filter Strip CP# 1 (DS) - DS Filter Strips # 1  
 Total drainage area (acres)= 1.303  
 Fraction of drainage area served by filter strips (ac) = 1.00  
 Total filter strip width (ft) = 655.0  
 Effective flow length (ft) = 18  
 Infiltration rate (in/hr)= 0.010  
 Typical longitudinal slope (ft.H/ft.V) = 0.080  
 Typical grass height (in) = 3.0  
 Swale retardance factor = C  
 Use stochastic analysis to determine infiltration rate: False  
 Infiltration rate coefficient of variation (COV) = 0.00  
 Particle size distribution file name: Not needed - calculated by program  
 Surface Clogging Load (lbs/sf) = 3.50

SLAMM for Windows Version 10.4.1  
 (c) Copyright Robert Pitt and John Voorhees 2019, All Rights Reserved

Data file name: S:\Design & Construction Services\Prairie Philip\SWMP\WinSLAMM\2022-08-05 Prairie Phillip.mdb  
 WinSLAMM Version 10.4.1  
 Rain file name: C:\WinSLAMM Files\Rain Files\WI Milwaukee 69.RAN  
 Particulate Solids Concentration file name: C:\WinSLAMM Files\10.1 WI\_AVG01.pscx

Runoff Coefficient file name: C:\WinSLAMM Files\WI\_SL06 Dec06.rsvx  
 Pollutant Relative Concentration file name: C:\WinSLAMM Files\WI\_GEO03.ppd  
 Residential Street Delivery file name: C:\WinSLAMM Files\WI\_Com Inst Indust Dec06.std  
 Institutional Street Delivery file name: C:\WinSLAMM Files\WI\_Com Inst Indust Dec06.std  
 Commercial Street Delivery file name: C:\WinSLAMM Files\WI\_Com Inst Indust Dec06.std  
 Industrial Street Delivery file name: C:\WinSLAMM Files\WI\_Com Inst Indust Dec06.std  
 Other Urban Street Delivery file name: C:\WinSLAMM Files\WI\_Com Inst Indust Dec06.std  
 Freeway Street Delivery file name: C:\WinSLAMM Files\WI\_Com Inst Indust Dec06.std  
 Apply Street Delivery Files to Adjust the After Event Load Street Dirt Mass Balance: False  
 Source Area PSD and Peak to Average Flow Ratio File: C:\WinSLAMM Files\NURP Source Area PSD Files.csv  
 Cost Data file name:  
 If Other Device Pollutant Load Reduction Values = 1, Off-site Pollutant Loads are Removed from Pollutant Load % Reduction calculations  
 Seed for random number generator: -42  
 Study period starting date: 03/28/69 Study period ending date: 12/06/69  
 Model Run Start Date: 03/28/69 Model Run End Date: 12/06/69  
 Date of run: 08-05-2022 Time of run: 15:25:51  
 Total Area Modeled (acres): 6.030  
 Years in Model Run: 0.67

	Runoff Volume (cu ft)	Percent Runoff Volume Reduction	Particulate Solids Conc. (mg/L)	Particulate Solids Yield (lbs)	Percent Particulate Solids Reduction
Total of all Land Uses without Controls:	62849	-	135.7	532.6	-
Outfall Total with Controls:	60546	3.66%	27.66	104.6	80.36%
Annualized Total After Outfall Controls:	90943			157.0	

# Appendix 4

## Storm Water Maintenance Plan

*Prairie Philip Outdoor Storage Yard*  
**STORM WATER  
 MAINTENANCE AGREEMENT**

EXHIBITS

**Exhibit A:** Legal Description of real estate for which this agreement applies (“Property”).

**Exhibit B:** Location Map(s) - shows an accurate location of each storm water management practice affected by this agreement.

**Exhibit C:** Details – shows details of basin outlet structure, spillway, etc. of each storm water management practice affected by this agreement.

**Exhibit D:** Maintenance Plan – prescribes those activities that must be carried out to maintain compliance with this agreement.

Name and Return Address

City of Waukesha  
 Attention: Gina Kozlik  
 Clerk Treasurer  
 201 Delafield Street  
 Waukesha, WI 53188

Parcel Identification Number (PIN)

Storm Water Management Measures  
 and  
 Maintenance Agreement

This Agreement is made and executed this \_\_\_\_\_ day of \_\_\_\_\_, 20\_\_ by \_\_\_\_\_, (hereinafter the “Owner” or “Developer”) and the City of Waukesha (hereinafter the “City”).

**WHEREAS**, Owner/Developer has subjected the Prairie Philip Outdoor Storage Yard Development located at the NW ¼ of the NW 1/4, Section 35, Township 7 North, Range 19 East, City of Waukesha, Waukesha County, to certain conditions which are expressly made a part hereof, and as approved by the City of Waukesha and is expressly made an integral part hereof, for the benefit of the Development, City, and the Tenants; and,

**WHEREAS**, Owner/Developer and City wish to set forth certain maintenance obligations as a separate recorded document, further documenting the obligations of Owner/Developer, any successors and assignees, and other impacted parties.

**WHEREAS**, the Owner/Developer, its successors and assigns, agree that the health, safety and welfare of the residents of the City require on-site storm water management and maintenance measures on the Property, and

**WHEREAS**, the City requires that on-site storm water management measures and management plans be implemented by the Owner/Developer, its successors and assigns,

**NOW, THEREFORE**, in compliance with the terms applicable to the Prairie Philip Outdoor Storage Yard Development, the parties agree as follows.

1. The Owner/Developer, its successors or assigns, shall be solely responsible for the maintenance, upkeep, and repair of the storm water management system of the Prairie Philip Outdoor Storage Yard Development.
2. Upon notification of the Owner/Developer, its successors or assigns, by the City of storm water management and maintenance problems, which require correction due to an adverse effect on property owners, public safety, or public health, the specified corrective actions shall be taken within a reasonable time frame as set by the City.
3. The City is authorized, but not required, to perform the corrective actions identified in the notice if the Owner/Developer, its successors or assigns does not make the required corrections in the specified time period. All costs and administrative fees charged to Owner/Developer, its successors or assigns in accordance with this section may be placed upon the tax roll as special charges in accordance with Wisconsin Statutes, including §66.0627, Wis. Stats.
4. The plans of the Prairie Philip Outdoor Storage Yard Development shall accurately describe certain areas, and shall be legally described and submitted by the Owner/Developer, its successors or assigns to the City, as detention/retention basins, swales, storm water easements, storm sewers, etc., all of which serve as and shall be referred to as storm water management measures and shall be fully incorporated herein as an integral part of this Agreement.
5. The Owner/Developer, its successors or assigns shall be responsible for maintenance of all storm water management measures. The City is authorized to access the Property to conduct annual, or more frequent as needed inspections, of storm water management features and practices as may be determined by the City or its

representatives, that are necessary to ascertain that the features and practices are being maintained and operated in accordance with acceptable standards designated by the City. The Owner/Developer, its successors or assigns, on an annual, or more often as needed basis as may be determined by the City or its representatives, shall provide maintenance of each storm water management measure, including but not limited to, removal of debris, maintenance of vegetative areas, maintenance of structural storm water management measures and sediment removal. Upon notification of the Owner/Developer, its successors or assigns by the City of maintenance problems which require correction, the specified corrective actions shall be taken within a reasonable time frame as set by the City.

6. In the event that maintenance of the storm water management measures is not undertaken by the Owner/Developer, its successors or assigns, the City shall perform maintenance work on the storm water management measures if such failure to maintain (a) has a material adverse effect on property other than the Prairie Philip Outdoor Storage Yard Development, or (b) endangers the public health or safety. However, before the City shall have the right to perform any such maintenance pursuant to this section (except in the case of an emergency situation), the City shall provide the Owner/Developer, its successors or assigns with written notice stating with specificity the maintenance activities the City deems to be required with respect to the storm water management measures. The Owner/Developer, its successors or assigns shall then have ten (10) days after receipt of such written notice to perform such maintenance, provided that said ten (10) day period shall be extended if the Owner/Developer, its successors, assigns or duly authorized designee has commenced such maintenance work within said ten (10) day period and is diligently proceeding to complete the same. In the case of an emergency situation as determined in the sole discretion of the City, no notice will be required prior to the City performing emergency maintenance. The Owner/Developer, its successors or assigns shall be liable for all costs and expenses incurred by the City for the failure to undertake any repairs.

7. The cost of inspections or any measures undertaken by the City pursuant to Paragraphs 3 or 6 of this Agreement shall be assessed against the Owner/Developer, its successors or assigns pro rata according to their fractional ownership interest in accordance with the provisions of §66.0627, Wis. Stats. It is expressly understood and acknowledged that such cost shall be deemed a special charge for current services and may be



levied in accordance with the provisions of §66.0627, Wis. Stats. Any such assessment which is not paid within sixty (60) days after billing shall be deemed a delinquent special charge and shall become a lien upon the parcel(s) against which such charge has been assessed. Such delinquent charges shall be extended upon the current or next tax roll as a delinquent tax against the parcel(s) for which payment has not been received by the City, and all proceedings in relation to the collection, return and sale of property for delinquent real estate taxes shall apply to such special charges.

8. This Agreement imposes no liability of any kind whatsoever on the City, and the Owner/Developer, its successors or assigns, agrees and promises to hold the City, its officers, employees and agents, harmless and indemnify said entity and persons from any and all liability, of whatever kind or nature, in the event the storm water management and maintenance measures fail to function or operate properly and any damages of whatever kind or nature resulting from said failure to function or operate properly.

9. This Agreement shall be recorded with the Waukesha County Register of Deeds Office and shall constitute a covenant running with the land and shall be bindings on the Owner/Developer, its administrators, executors, assigns, heirs, and any other successors in interests and title.

10. The validity, meaning and effect of this Agreement shall be construed in accordance with the laws of the State of Wisconsin. This Agreement constitutes the entire agreement of the parties with respect to the subject matter thereof.

11. Each provision of this Agreement shall be considered separable, and if for any reason any provision or provisions are determined to be invalid and contrary to any existing or future law, the invalidity shall not impair the operation of those portions of this Agreement that are valid.

12. Venue for any disputes arising out of or under this Agreement shall be in the Circuit Court for Waukesha County, Wisconsin.

Dated this \_\_\_\_ day of \_\_\_\_\_, 20\_\_.

OWNER/DEVELOPER:

Prairie Philip, LLC

By: \_\_\_\_\_

Name (please print or type): Eugene Sheedy

Title (please print or type): Managing Member

STATE OF WISCONSIN)  
WAUKESHA COUNTY) ss

Personally came before me this \_\_\_\_\_ day of \_\_\_\_\_, 20\_\_ , the above named \_\_\_\_\_  
\_\_\_\_\_ to me known to be the same person who executed the foregoing instrument and  
acknowledged the same.

\_\_\_\_\_  
Notary Public

\_\_\_\_\_ County, Wisconsin

My Commission Expires \_\_\_\_\_

CITY:

City of Waukesha

By: \_\_\_\_\_

Kevin Lahner, City Administrator

Attest: \_\_\_\_\_

Gina Kozlik, Clerk Treasurer

# **Exhibit A**

## **Legal Description**

Prairie Philip Outdoor Storage Yard

Pewaukee Road, City of Waukesha, Waukesha County, WI

ALL THAT PART OF THE NORTHWEST 1/4 OF THE NORTHWEST 1/4 OF SECTION 35, TOWNSHIP 7 NORTH, RANGE 19 EAST, DESCRIBED AS FOLLOWS, TO-WIT: COMMENCING AT A POINT ON THE WEST LINE OF THE SAID QUARTER SECTION, DISTANT SOUTH 400.00 FEET FROM THE NORTHWEST CORNER OF THE SAID SECTION; THENCE NORTH 88° 30' EAST 1328.30 FEET TO THE 1/8TH LINE OF THE SAID QUARTER SECTION; THENCE SOUTH 01° 15' WEST ON SAID LINE 173.71 FEET; THENCE SOUTH 88° 30' WEST 1324.51 FEET TO THE SECTION LINE; THENCE NORTH 173.71 FEET TO THE POINT OF COMMENCEMENT.

EXCEPTING THEREFROM THOSE LANDS CONTAINED IN AWARD OF DAMAGES RECORDED DECEMBER 2, 1990 AS DOCUMENT NO. 1626799. SAID LAND BEING IN THE CITY OF WAUKESHA (FORMERLY TOWN OF PEWAUKEE), WAUKESHA COUNTY, WISCONSIN.



# Exhibit B

## Location Map

### Prairie Philip Outdoor Storage Yard

#### Pewaukee Road, City of Waukesha, Waukesha County, WI

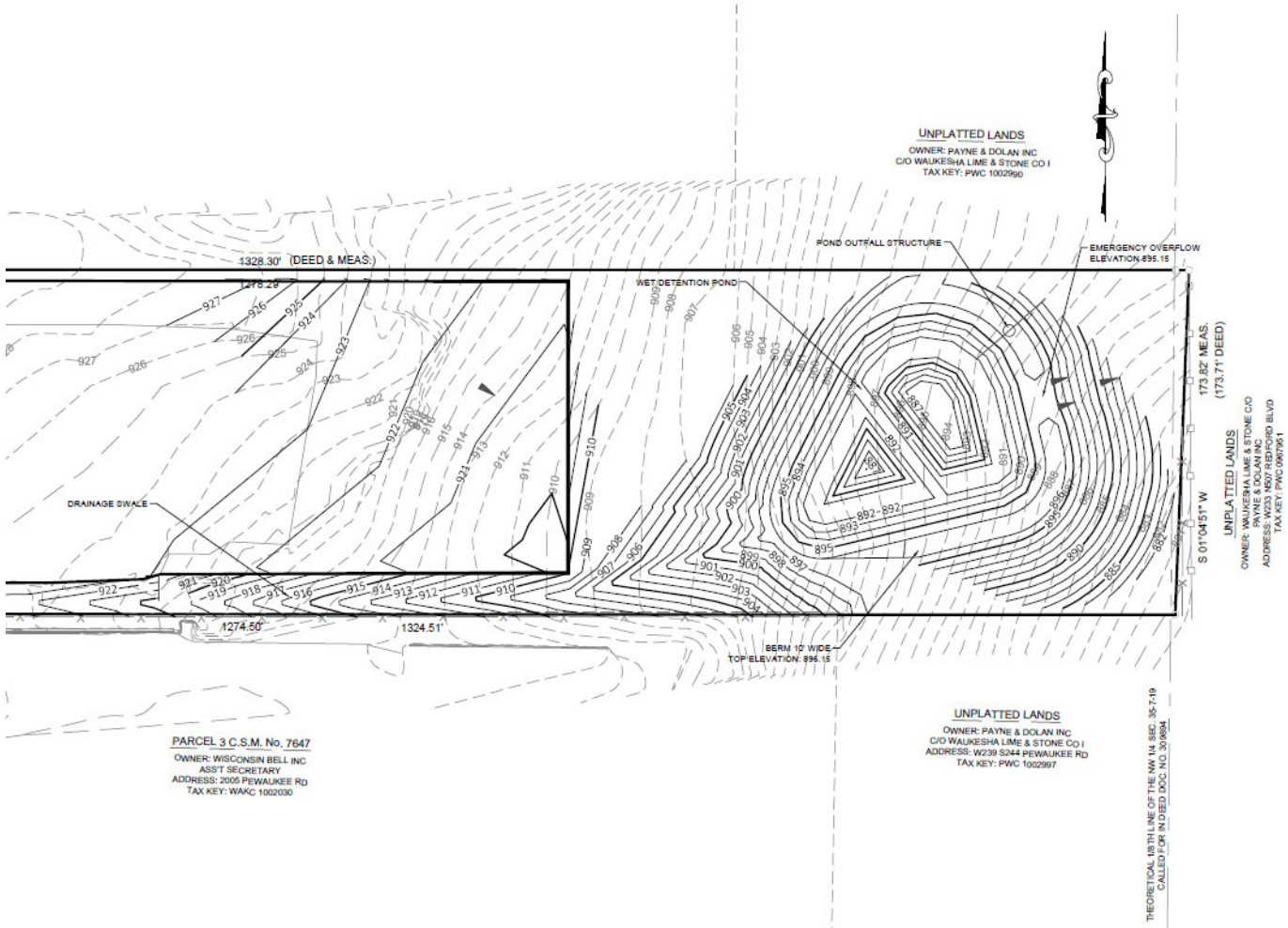

# Exhibit C

## Storm Water Details

### Prairie Philip Outdoor Storage Yard

#### Pewaukee Road, City of Waukesha, Waukesha County, WI

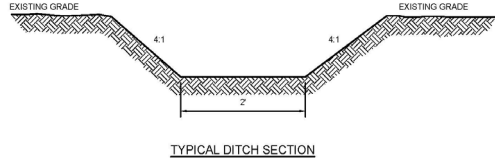

WET POND #1 DATA	ELEV
TOP OF BERM	896.15
SPILLWAY	895.15
100-YR WSEL	895.14
2-YR WSEL	893.65
PERMANENT POOL	892.00
PERMANENT BOTTOM	887.00

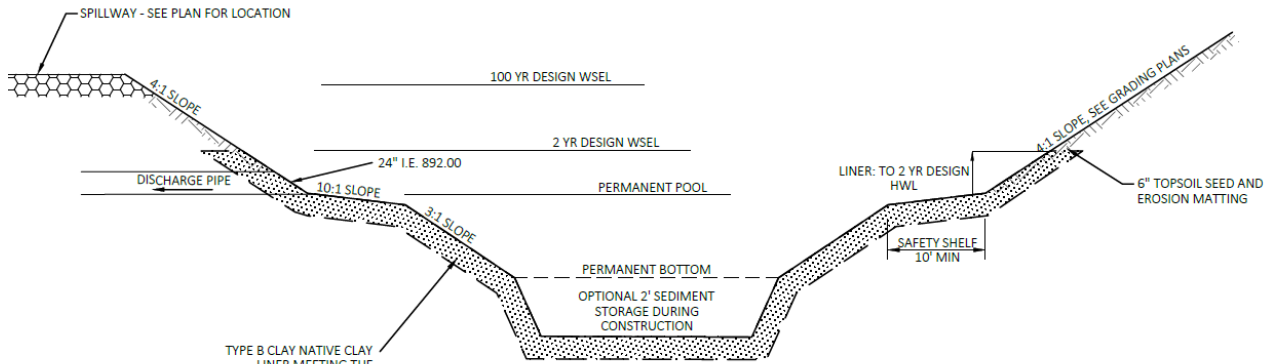

TYPE B CLAY NATIVE CLAY LINER MEETING THE CRITERIA OF WDNR TECHNICAL STANDARD 1001, APPENDIX D SECTION C. 1.

NTS  
 3/4" GARDEN MESH NETTING SHALL BE ATTACHED TO REBAR POSTS AND HUNG OVER WET BASIN AND RIPRAP SHALL BE INSTALLED A MINIMUM OF 2' ABOVE PERMANENT POOL IN RESPONSE TO FAA EFFORTS TO MITIGATE THE HAZARDS TO HUMAN FLIGHT AS POSED BY WILDLIFE.

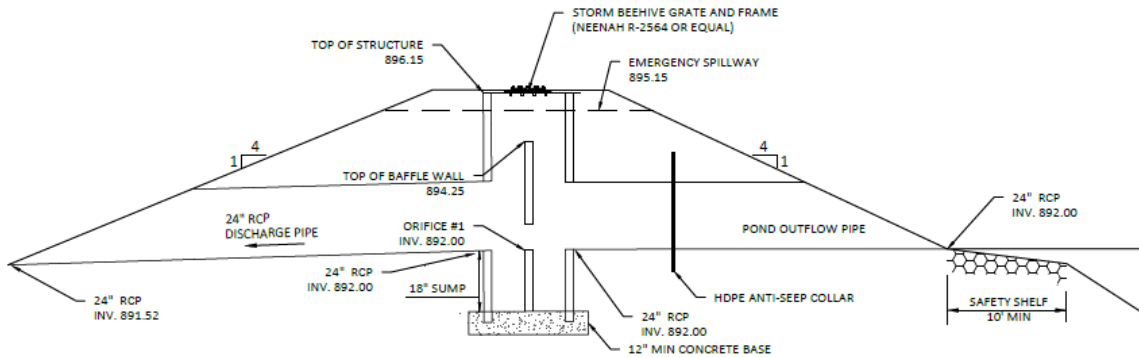

NTS

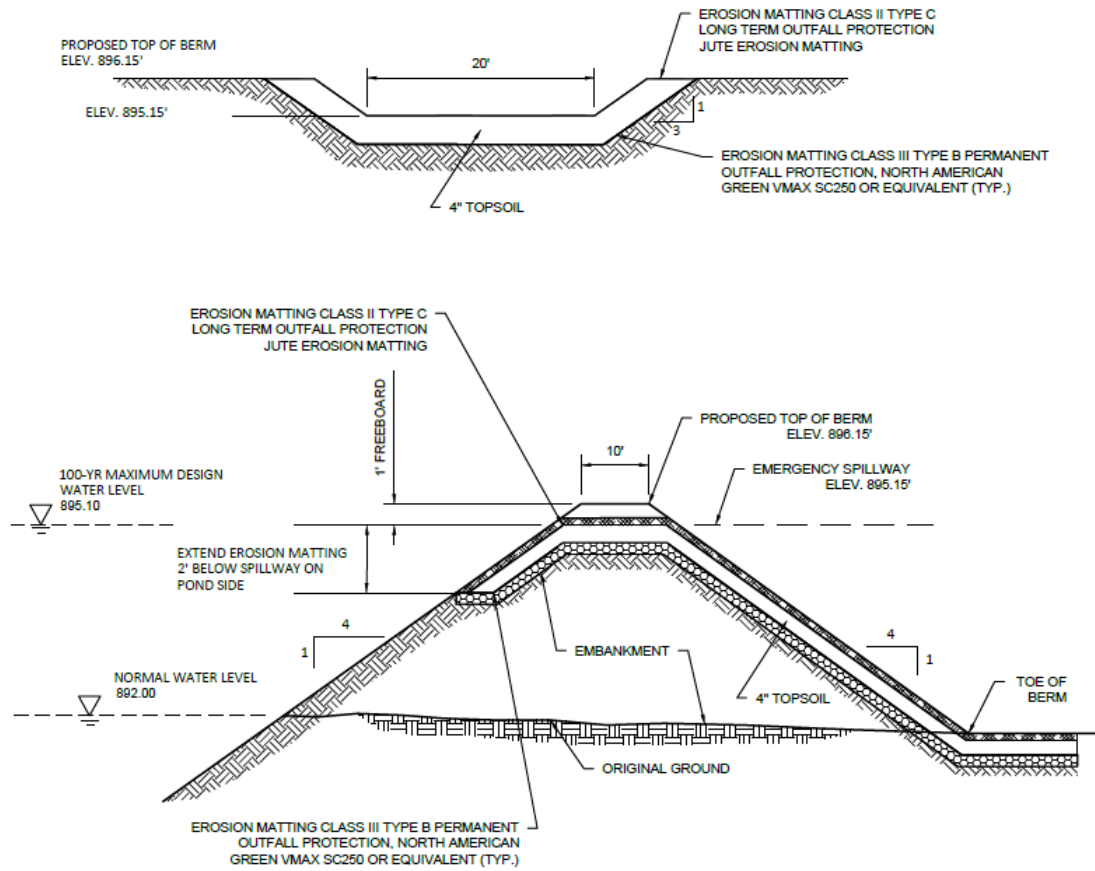

PROPOSED EMERGENCY SPILLWAY WET POND

**Exhibit D**  
**Storm Water Practice Maintenance Plan**  
Prairie Philip Outdoor Storage Yard  
Pewaukee Road, City of Waukesha, Waukesha County, WI

This exhibit explains the basic function of each of the storm water practice on the subject property and prescribes the minimum maintenance requirements to remain compliant with this Agreement. The maintenance activities listed below are aimed to ensure these practices continue serving their intended functions in perpetuity. The list of activities is not all inclusive, but rather indicates the minimum type of maintenance that can be expected for this particular site.

System Description:

A stormwater treatment train has been designed for the property to reduce the post-development storm water release rates and remove a minimum 80% of the total suspended solids from the storm water prior to discharging onto adjacent properties. To do this, a grass swale and a wet detention basin with outlet control structure must be inspected and maintained on a regular basis. The site discharges offsite to the southeast and is ultimately tributary to the Fox River.

The stormwater pond receives runoff from the new gravel outdoor storage area. A grass swale is being constructed along the south property line to convey this area to the stormwater pond. During rainfall or snow melt events, the water level in the wet pond will temporarily rise and slowly drain down to the elevation of the outfall pipe invert. Performance of the wet detention pond can be monitored by observing the inflow and outflow characteristics of the storm water at the outlet structure on the side of the pond.

Minimum Maintenance Requirements:

To ensure the proper long-term function of the storm water management practices described above, the following activities must be completed:

**WET DETENTION POND**

1. The wet detention pond is anticipated to have a service life of 20-30 years with proper maintenance of the upstream tributary areas before dredging is required to remove accumulated sediment. At present, the material is required to be disposed of as hazardous waste.
2. Storm water discharge from the outlet structure should be monitored semi-annually. The water should appear clear and stop flowing 72-hours or less following a rain event.
3. At least once per year during a heavy rainfall event, the outlet structure should be visually inspected to ensure that the system is operating effectively and that water levels are below the anticipated 100-yr water surface elevations with no visual indications of bypass occurring.

**MOWED LAWN AREAS (ROUTINE MOWING)**

1. Lawn areas are anticipated to be mowed weekly during the growing season. Careful attention should be paid to ensure that lawn clippings are not blow into the inlets or left along the curb lines. Lawn clippings have the potential to cause excess algae growth in the wet detention pond.
2. Limiting mowing frequency of grass swale areas will encourage a vigorous grass cover and allow better protection against soil erosion.

A yearly inspection is required. An inspection form, as provided by the City of Waukesha or the form included in this document, must be filled out by a qualified person that represents the Owner. Any needed maintenance or repairs must be documented and scheduled immediately. All maintenance or repairs must be documented, preferably with photographs. The completed inspection form and documentation must be forwarded to the City Engineer. Failure to complete the yearly inspection may be cause for the City to inspect the basin and conveyances, at the Owner's cost, as outlined above and all other repairs or maintenance needed to ensure the continued function of the basin as ordered by the City of Waukesha under the provisions previously listed in this Agreement.





# Appendix 5

## USLE Soil Loss Calculation, Erosion Control Plan and Storm Water Details



NO.	REVISION DESCRIPTION	DATE
A	CITY REVIEW COMMENTS	07/20/2021
B	CITY REVIEW COMMENTS	08/02/2021
C	CLIENT REVISIONS	08/25/2021
D	CLIENT REVISIONS	08/30/2021



**OUTDOOR STORAGE YARD**  
 2105 PEWAKUEE ROAD  
 WAUKESHA, WI 53188

CLIENT  
**PRAIRIE PHILIP LLC**  
 200 S. PRAIRIE AVENUE  
 WAUKESHA, WI 53186

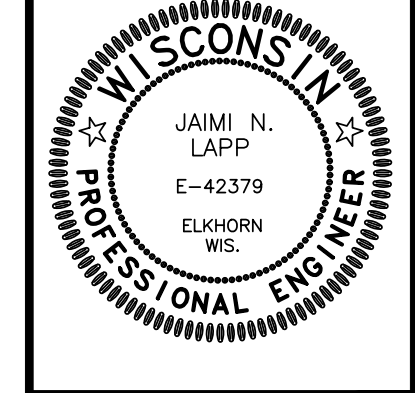

**GRADING AND EROSION CONTROL PLAN**

PROJECT TITLE

COPYRIGHT NOTICE  
 THESE DRAWINGS AS INSTRUMENTS OF SERVICE REMAIN THE PROPERTY OF PAYNE & DOLAN, INC. ANY CHANGES, PUBLICATION, OR UNAUTHORIZED USE IS PROHIBITED UNLESS EXPRESSLY AUTHORIZED BY PAYNE & DOLAN, INC.

Drawing Scale: 1:50  
 Drawn: GME 04/26/2021  
 Checked: JNL 04/26/2021  
 P&D Project No: 490493  
 Sheet No: **02**

**ISSUED FOR CONSTRUCTION**

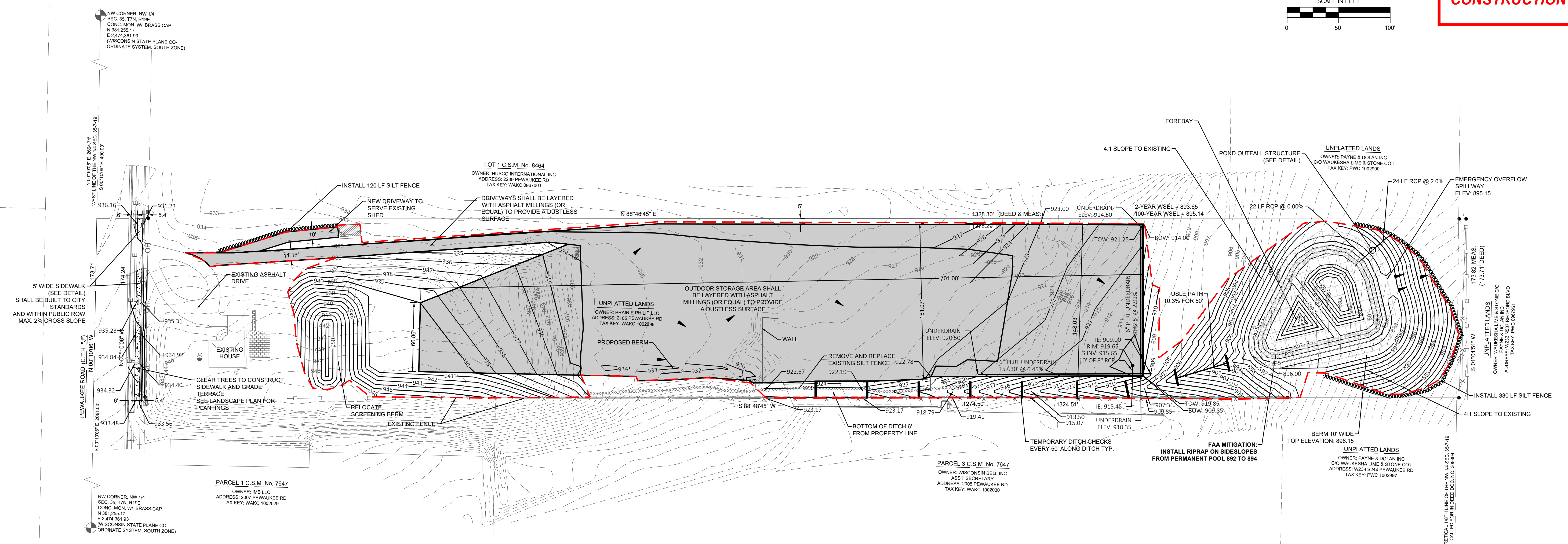
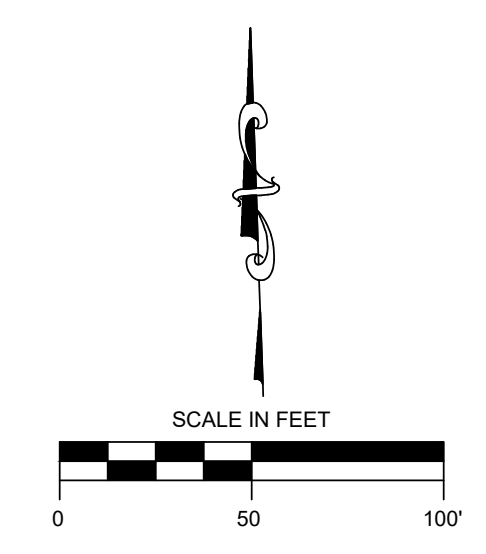

**CONSTRUCTION SEQUENCE**

ESTIMATED CONSTRUCTION TIMEFRAMES\*:  
 INSTALL EROSION CONTROL MEASURES = SEPTEMBER 2022  
 GRADE WET POND AND SWALE = SEPTEMBER 2022  
 FINE GRADING = OCTOBER 2022  
 FINAL RESTORATION = OCTOBER 2022

THE INTENDED SEQUENCES OF SITE CONSTRUCTION ACTIVITIES ARE AS FOLLOWS:

- INSTALL EROSION CONTROL MEASURES AS INDICATED ON THE EROSION CONTROL PLAN AND IN ACCORDANCE WITH THE REQUIREMENTS OF WINDR CONSERVATION PRACTICE STANDARDS PRIOR TO ANY LAND DISTURBING ACTIVITIES.
- FINE GRADE.
- INSTALL LANDSCAPING/RESTORATION.
- WHEN THE SITE VEGETATION HAS BEEN ESTABLISHED AND THE POTENTIAL OF EROSION IS STABILIZED, THE TEMPORARY EROSION CONTROL MEASURE WILL BE REMOVED.

\*CONSTRUCTION ACTIVITY DATES ARE APPROXIMATE AND MAY CHANGE DUE TO WEATHER OR OTHER UNFORESEEN REASONS.

**EROSION CONTROL NOTES:**

- SILT FENCE SHALL BE INSTALLED AS INDICATED ON THE EROSION CONTROL PLAN.
- ALL DISTURBED AREAS WILL REQUIRE TOPSOIL, FERTILIZER, SEED & MULCH. PLACE SEEDING MIXTURE NO. 40 AT A RATE OF 2 LB PER 1000 SF PER WISDOT STANDARD SPEC 630. PLACE FERTILIZER TYPE B AT A RATE OF 7 LB PER 1000 SF PER WISDOT STANDARD SPEC 629.
- INSPECT AND REPAIR ALL SEDIMENT CONTROL STRUCTURES AT LEAST EVERY 7 DAYS AND WITHIN 24 HRS AFTER EVERY RAINFALL GREATER THAN 1/2".
- MAINTAIN EROSION CONTROL FACILITIES THROUGHOUT THE DURATION OF THE PROJECT AND WARRANTY PERIOD IN CONFORMANCE WITH DNR WIDES GENERAL PERMIT (IF APPLICABLE).
- THE CONTRACTOR IS RESPONSIBLE FOR INSTALLATION OF ANY ADDITIONAL EROSION CONTROL MEASURES NECESSARY TO PREVENT EROSION AND SEDIMENTATION.
- ALL DISTURBED AREAS ARE TO DRAIN TO APPROVED SEDIMENT CONTROL MEASURES AT ALL TIMES DURING SITE DEVELOPMENT UNTIL FINAL STABILIZATION IS ACHIEVED.
- THE CONTRACTOR IS RESPONSIBLE FOR OBTAINING COPIES OF ALL PERMITS. CONTRACTOR IS RESPONSIBLE FOR ABIDING BY ALL PERMIT REQUIREMENTS AND RESTRICTIONS.

NOTE:  
 ALL EQUIPMENT/STORAGE SHALL BE CONTAINED WITHIN THE DUSTLESS SURFACE LIMITS.

Activity (1)	Begin Date (2)	End Date (3)	Period % R (4)	Annual R Factor (5)	Sub Soil Texture (6)	Soil Erodibility K Factor (7)	Slope (%) (8)	Slope Length (ft) (9)	LS Factor (10)	Land Cover C Factor (11)	Soil loss A (tons/acre) (12)	SDF (13)	Sediment Control Practice (14)	Sediment Discharge (t/acre) (15)
Bare Ground	09/01/22	09/15/22	7.0%	130	Silt Loam	0.43	10.3%	50	1.02	1.00	4.0	0.702	Ditch Check Sed	2.0
Seed with Mulch or E	09/15/22	12/01/22	12.0%	130	Silt Loam	0.43	10.3%	50	1.02	0.10	0.7	0.702	Ditch Check Sed	0.3
End	12/01/22						10.3%	50	1.02			0.000		0.0
							10.3%	0				0.000		0.0
							0.0%	0				0.000		0.0
<b>TOTAL</b>											<b>4.7</b>	<b>TOTAL</b>	<b>2.3</b>	
													<b>% Reduction Required</b>	<b>NONE</b>

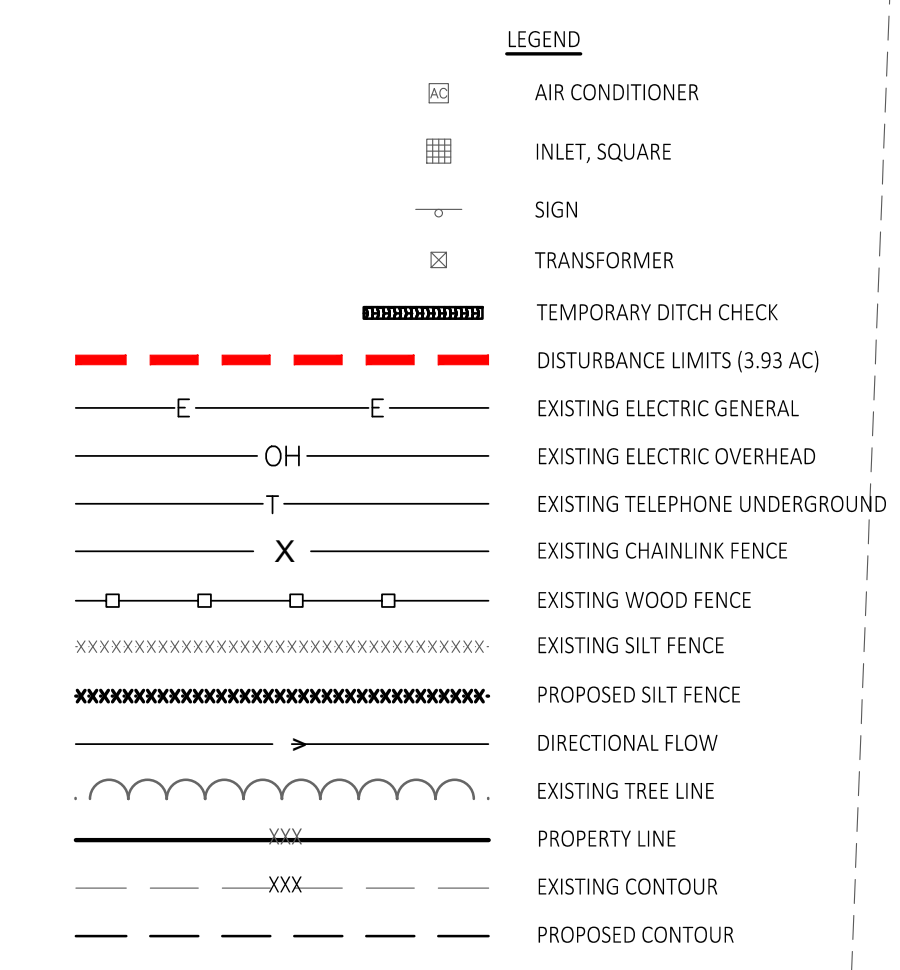

THE LOCATIONS OF EXISTING UTILITY INSTALLATIONS AS SHOWN ON THIS PLAN ARE APPROXIMATE. THERE MAY BE OTHER UNDERGROUND UTILITY INSTALLATIONS WITHIN THE PROJECT AREA THAT ARE NOT SHOWN. CONTRACTORS SHALL MAKE THEIR OWN DETERMINATION AND VERIFY THE LOCATION OF UNDERGROUND UTILITIES.

THE CLIENT AND/OR OTHER RECIPIENTS AGREE TO THE FULLEST EXTENT PERMITTED BY LAW TO INDEMNIFY AND HOLD PAYNE AND DOLAN HARMLESS FOR ANY REUSE OF OR FROM CHANGES MADE TO THE ORIGINAL DRAWING OR DATA WITHOUT PRIOR WRITTEN CONSENT BY PAYNE AND DOLAN.

**DIGGERS HOTLINE**  
 Toll Free (800) 242-8511  
 Milwaukee Area (414) 259-1181  
 Hearing Impaired TDD (800) 542-2289  
 www.DiggersHotline.com

THE INFORMATION SHOWN ON THIS DRAWING CONCERNING TYPE AND LOCATION OF UNDERGROUND UTILITIES IS NOT GUARANTEED TO BE ACCURATE OR ALL INCLUSIVE. THE CONTRACTOR IS RESPONSIBLE FOR MAKING HIS OWN DETERMINATIONS AS TO THE TYPE AND LOCATION OF UNDERGROUND UTILITIES AS MAY BE NECESSARY TO AVOID DAMAGE THERETO. IF ADDITIONAL UTILITIES ARE KNOWN TO EXIST IN THE PROPERTY, THE OWNER WILL PROVIDE EXISTING PLANS OF OTHER UTILITIES SERVING THE SITE AND THE BUILDING THAT OTHERWISE CANNOT BE LOCATED BY A VISUAL OBSERVATION OF THE PROPERTY OR OF WHICH THE SURVEYOR WOULD HAVE NO KNOWLEDGE.



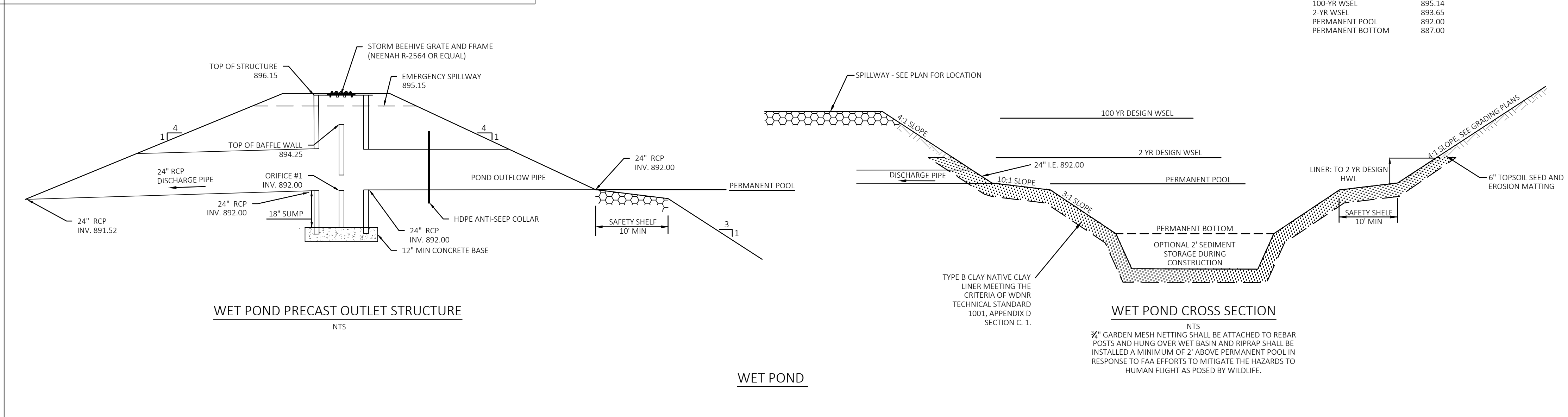
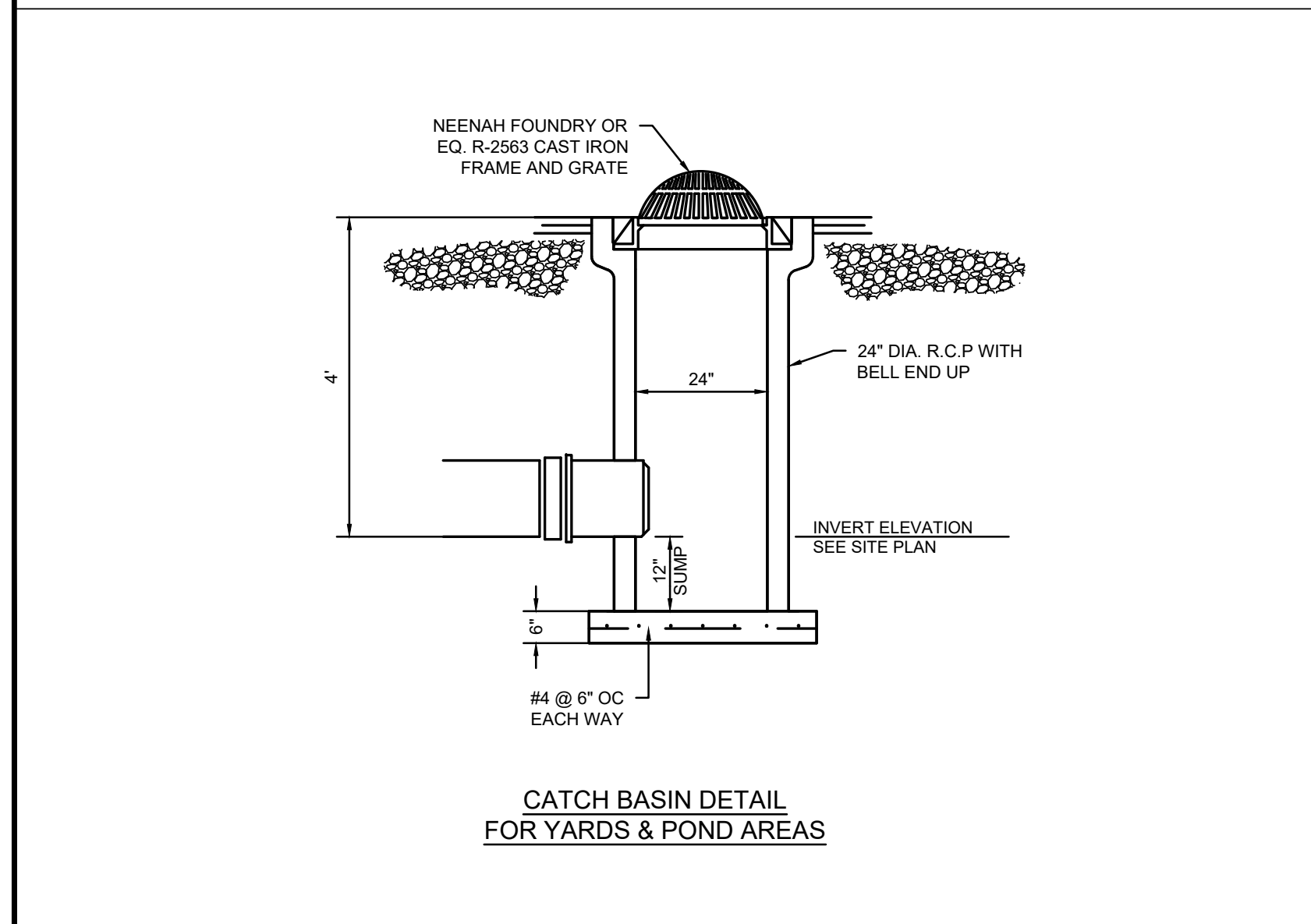
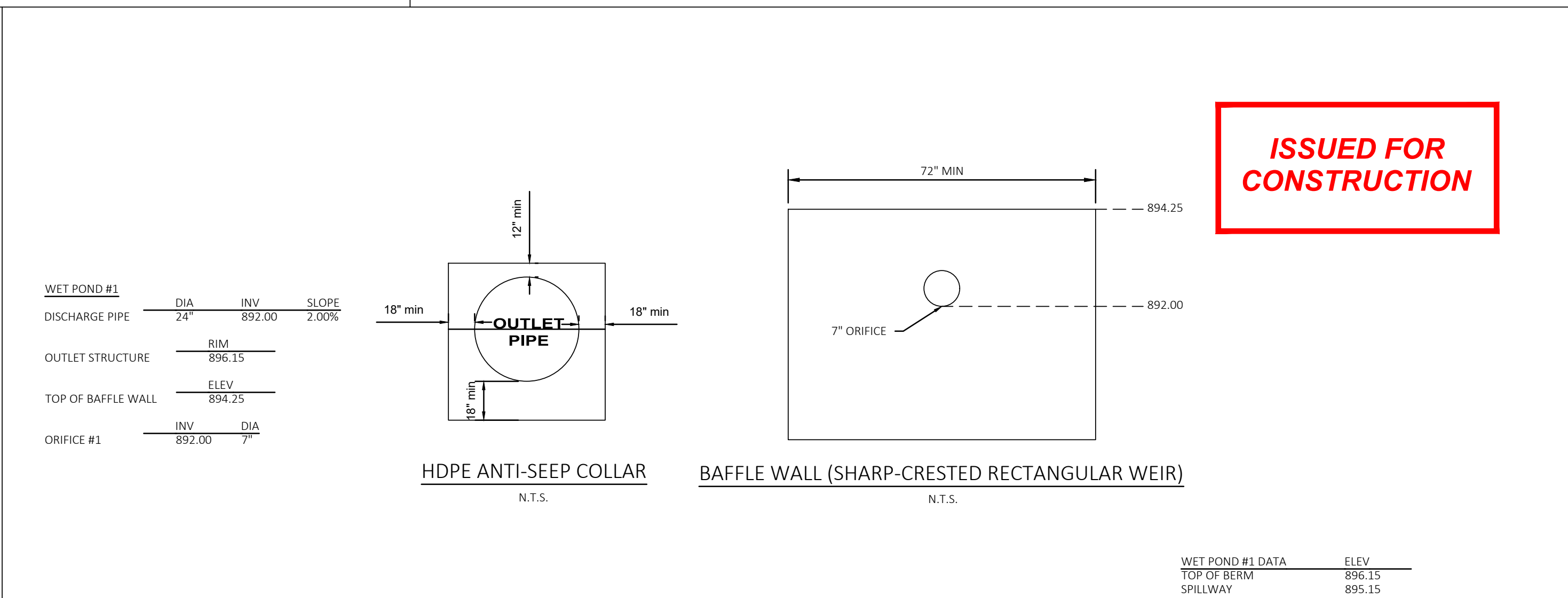
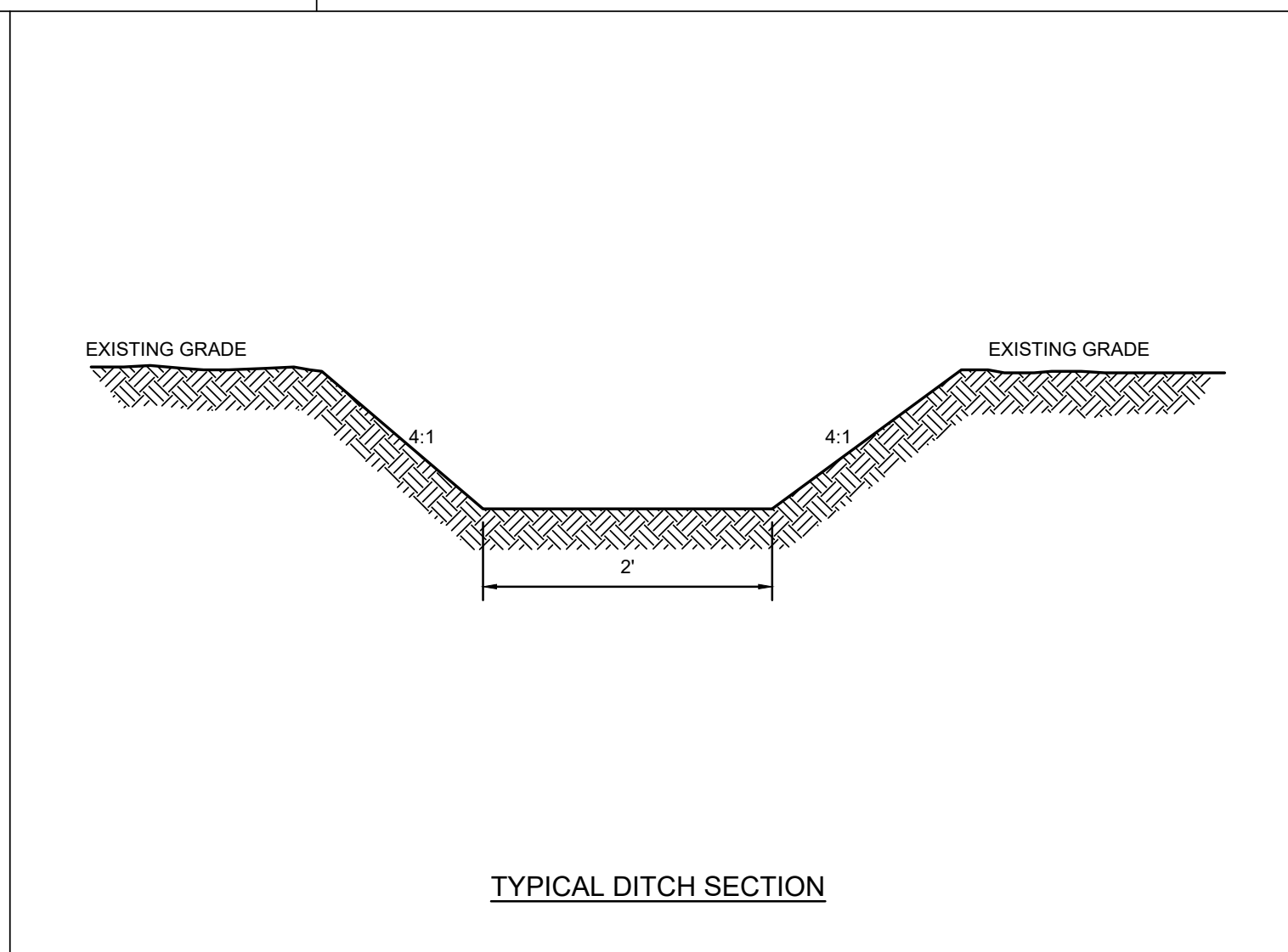
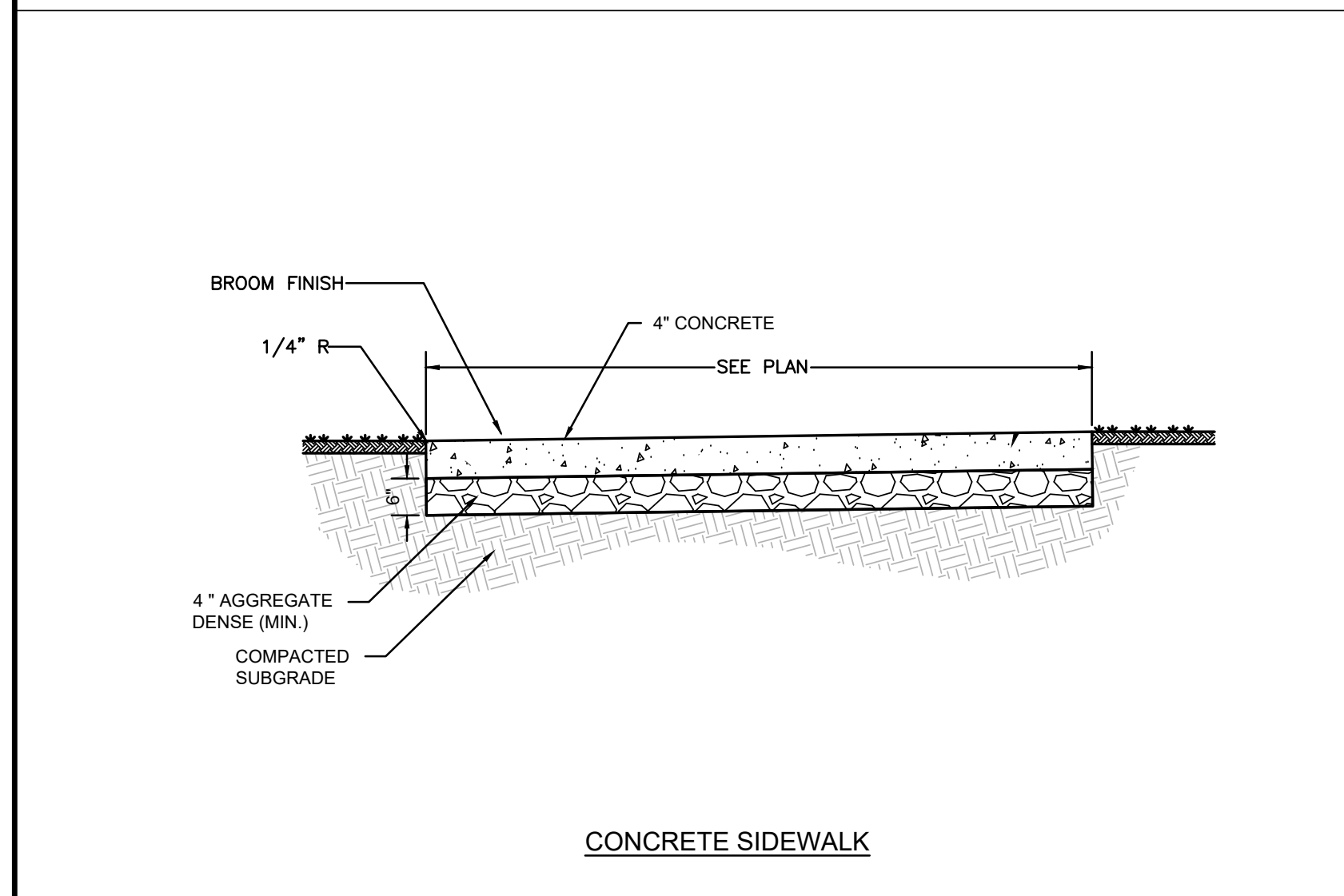
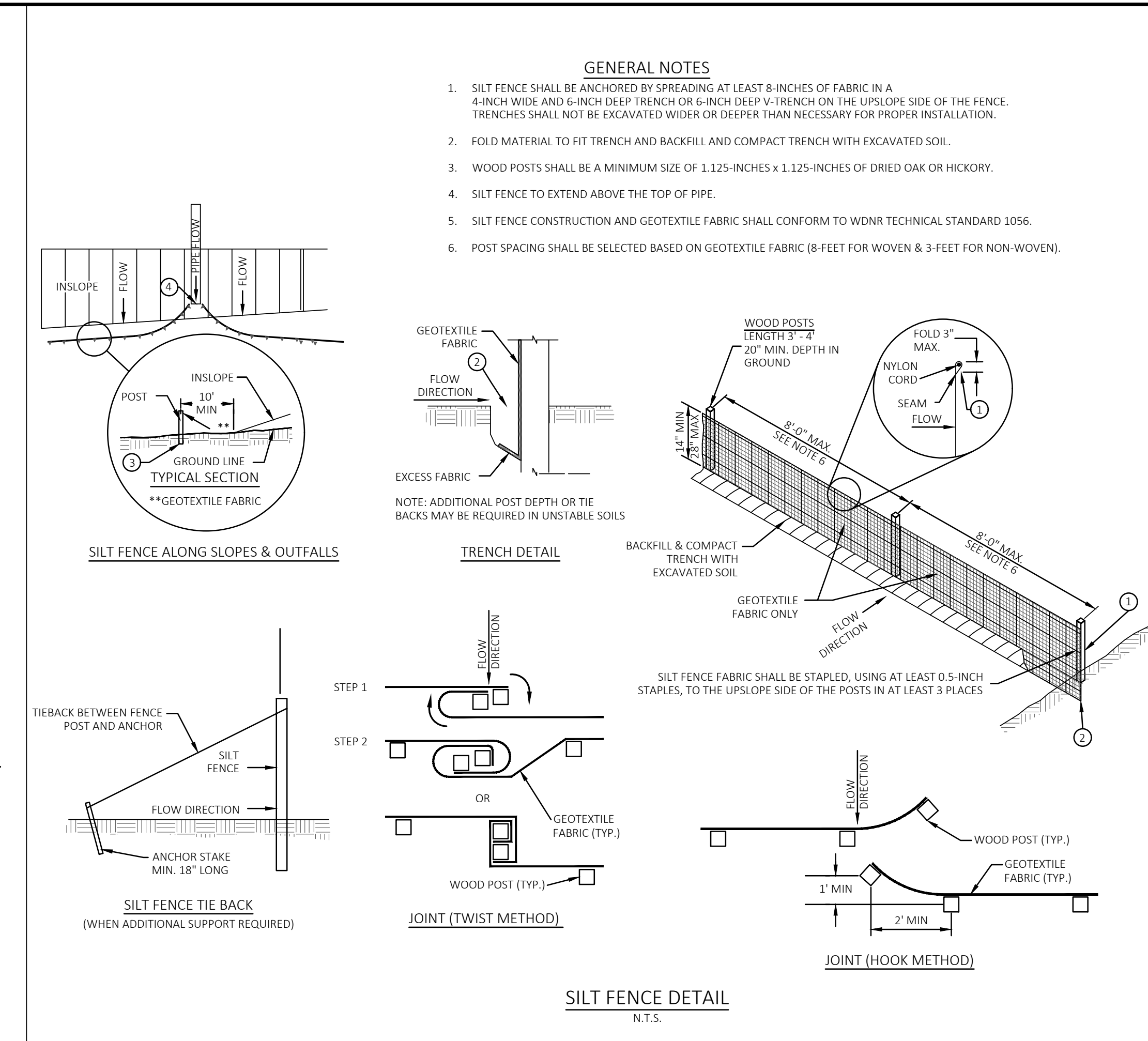
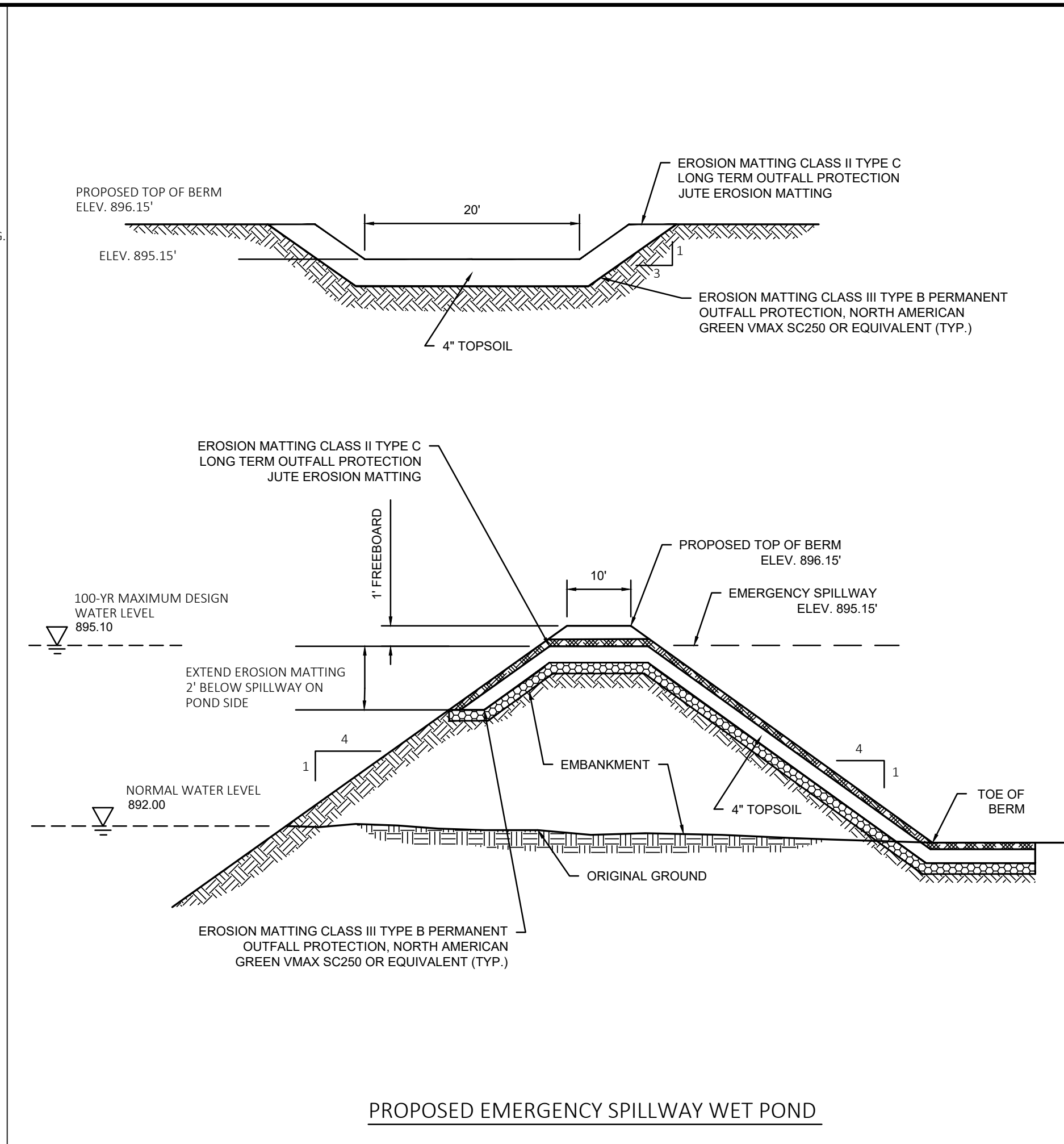
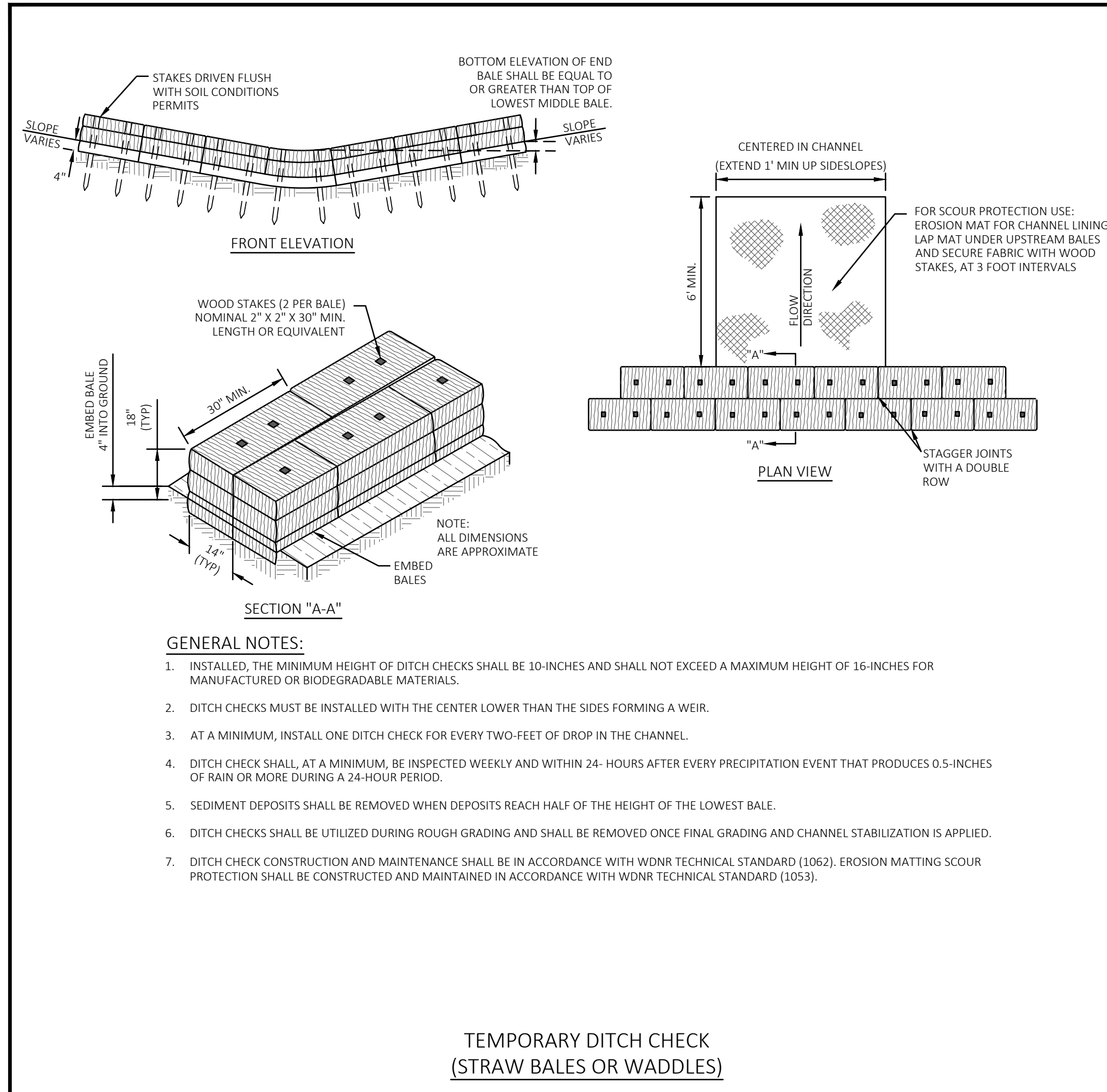

**ISSUED FOR CONSTRUCTION**

NO.	REVISION DESCRIPTION	DATE
A	CITY REVIEW COMMENTS	02/14/2021
B	CITY REVIEW COMMENTS	04/20/2021
C	CITY REVIEW COMMENTS	05/25/2021
D	CITY REVIEW COMMENTS	06/02/2021
E	CITY REVIEW COMMENTS	06/02/2021
F	CITY REVIEW COMMENTS	06/02/2021
G	CITY REVIEW COMMENTS	06/02/2021
H	CITY REVIEW COMMENTS	06/02/2021
I	CITY REVIEW COMMENTS	06/02/2021
J	CITY REVIEW COMMENTS	06/02/2021
K	CITY REVIEW COMMENTS	06/02/2021
L	CITY REVIEW COMMENTS	06/02/2021
M	CITY REVIEW COMMENTS	06/02/2021
N	CITY REVIEW COMMENTS	06/02/2021
O	CITY REVIEW COMMENTS	06/02/2021
P	CITY REVIEW COMMENTS	06/02/2021
Q	CITY REVIEW COMMENTS	06/02/2021
R	CITY REVIEW COMMENTS	06/02/2021
S	CITY REVIEW COMMENTS	06/02/2021
T	CITY REVIEW COMMENTS	06/02/2021
U	CITY REVIEW COMMENTS	06/02/2021
V	CITY REVIEW COMMENTS	06/02/2021
W	CITY REVIEW COMMENTS	06/02/2021
X	CITY REVIEW COMMENTS	06/02/2021
Y	CITY REVIEW COMMENTS	06/02/2021
Z	CITY REVIEW COMMENTS	06/02/2021

**PaynetDolan**  
A WALBECC COMPANY  
www.walbeccgroup.com  
(800) 757-7598

**PROJECT**  
OUTDOOR STORAGE YARD  
2105 PEWAUKEE ROAD  
WAUKESHA, WI 53188

**CLIENT**  
PRAIRIE PHILIP LLC  
200 S. PRAIRIE AVENUE  
WAUKESHA, WI 53186

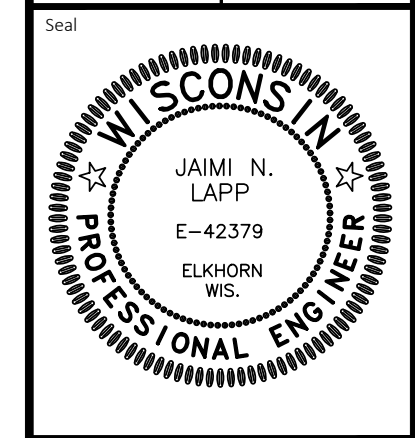

**DETAILS**

**COPYRIGHT NOTICE**  
THESE DRAWINGS AND INSTRUMENTS OF SERVICE REMAIN THE PROPERTY OF PAYNE & DOLAN, INC. ANY CHANGES, PUBLICATION, OR UNAUTHORIZED USE IS PROHIBITED UNLESS EXPRESSLY AUTHORIZED BY PAYNE & DOLAN, INC.

Drawing Scale:  
Drawn: GME 04/26/2021  
Checked: JNL 04/26/2021  
P&D Project No: 490493  
Sheet No: 04

Aug 05, 2022 4:40pm  
S:\design & construction services\080-C30-prairie philip\030-sheetsplan\Details.dwg