

WB-65 - Interstate Semi-Trailer
 Overall Length 73.50ft
 Overall Width 8.50ft
 Overall Body Height 12.05ft
 Min Body Ground Clearance 1.334ft
 Max Track Width 8.50ft
 Lock-to-lock time 6.00s
 Curb to Curb Turning Radius 45.000ft

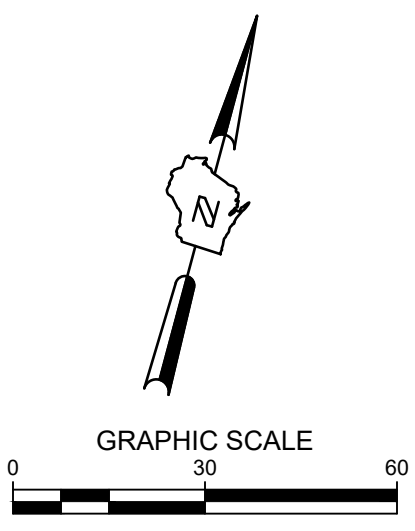

WILDE SUBARU
E MORELAND BLVD & MANHATTAN DR
WAUKESHA, WI

TRUCK TURNING MOVEMENTS

PRELIMINARY
NOT FOR
CONSTRUCTION

ISSUANCE	DATE
90% PLANS	09/11/23

NO. REVISION	DATE

PROJECT NO:	21736
DESIGN DATE:	---
PLOT DATE:	2023.10.20
DRAWN BY:	---
CHECKED BY:	---
APPROVED BY:	---
SHEET NO:	EX 2