

**From:** [tiltvision.art](mailto:tiltvision.art)  
**To:** [Maria Pandazi](#)  
**Subject:** RFP-Friedman Alley Murals City of Waukesha-Tilt Vision Art  
**Date:** Friday, June 5, 2026 8:54:27 AM  
**Attachments:** [image1780666841714](#)  
[image1780667488192](#)  
[Tilt Vision Art Threads of Waukesha Budget Scope Revised.pdf](#)  
[Tilt Vision Art RFO Portfolio.pdf](#)  
[7F90CD30-3427-4E56-BA75-4D5F7F105EE2.png](#)

You don't often get email from [tiltvision.art@protonmail.com](mailto:tiltvision.art@protonmail.com). [Learn why this is important](#)

**NOTICE: External Email**

This email message originated from outside the City of Waukesha. Do not click on links or open attachments unless you have verified the sender. If there is concern, please report this email.

Dear Selection Committee,

Thank you for the opportunity to submit our proposal for the Friedman Alley Mural Project. Attached you will find our concept board, artist qualifications, project budget, portfolio samples, and supporting materials for your review.

#### ABOUT THE ARTIST TEAM

Tilt Vision Art is a collaborative studio led by Brad Smith and Kay Ray.

Brad Smith has more than 40 years of experience as a professional muralist and public artist. His work helped define the visual identity of Dallas' Deep Ellum district during its formative years, creating murals that became part of the neighborhood's cultural legacy. Throughout his career he has focused on developing a system of Art based economic development. Throughout his career, he has completed public, educational, corporate, hospitality, and community-based projects across Texas and beyond.

Kay Ray is an artist, designer, and creative director whose work focuses on storytelling, placemaking, and community engagement through public art. Together, Brad and Kay create immersive mural experiences that celebrate local identity while encouraging exploration, connection, and civic pride.

#### RELEVANT PUBLIC ART EXPERIENCE

- Texas Wesleyan University – “Where Leaders Begin” Anniversary Mural, Fort Worth, Texas
- Echo Alley Public Art Initiative, Burleson, Texas
- City of Garland, Garland, Texas
- Pathway Christian Academy Murals, Fort Worth, Texas
- Magnolia RV Resort Mural, Waco, Texas
- Deep Ellum Historic Murals, Dallas, Texas
- Numerous community, educational, and commercial mural installations throughout Texas

Dallas Observer

Article <https://share.google/bGWc2QICKEfsGoOCw>

## PROJECT CONCEPT

Our proposed concept, “Threads of Waukesha,” celebrates the people, places, music, culture, and natural beauty that define Waukesha.

Inspired by the Fox River as a symbolic thread connecting the city’s stories, the mural transforms Friedman Alley into a walkable visual journey through Waukesha’s past, present, and future. Five oversized vintage postcard panels highlight iconic themes including the Fox River, Historic Downtown, Les Paul and Waukesha’s musical heritage, the Riverwalk, and the city’s vibrant arts and culture community.

Painted ribbons and musical notes weave throughout the composition, visually connecting each story while respecting the existing architecture of the Thomas Press building.

## SUPPORTING MATERIALS INCLUDED

1. Threads of Waukesha Concept Board
2. Artist Qualifications & Portfolio
3. Project Budget
4. Project References
5. Dallas Observer article featuring Brad Smith and the Deep Ellum O.G.’s exhibition
6. Portfolio pictures

The attached budget outlines a turnkey project including design, fabrication coordination, materials, installation, travel, lodging, painting, and protective coatings.

We would be honored to contribute to the continued revitalization of Friedman Alley and create an artwork that celebrates Waukesha's history, culture, and community spirit for years to come. We look forward to collaborating with you and helping to make your vision come to life.

Thank you for your consideration.

Kay Ray-Smith  
Director



[817-703-8141](tel:817-703-8141)

Sent with [Proton Mail](#) secure email.

# THREADS OF WAUKESHA

*A Journey Through the City's History, Culture and Connection to the Fox River*

Like the Fox River itself, stories flow through Waukesha. Five oversized postcards connected by painted ribbons celebrate the people, places, music, and history that continue to shape the city's identity.



AREA ONE – EAST WALL  
APPROX. 125' WIDE X 13' HIGH



AREA TWO – ALLEY WALL  
APPROX. 4' WIDE X 12' HIGH



OVERALL ELEVATION



AREA TWO (SOUTH WALL)  
APPROX. 4' WIDE X 12' HIGH



ALLEY GATEWAY MARKER  
INTO FRIEDMAN ALLEY

## CONCEPT

The Fox River weaves together the stories that define Waukesha—our history, vibrant downtown, music heritage, welcoming riverwalk, and thriving arts and culture. Oversized postcards create bold, inviting moments of discovery for all who walk the alley.

## POSTCARD PANELS (TYP.)



Five oversized postcard panels  
(8' x 5' each)

## DETAIL VIEWS



LAYERED POSTCARD  
WITH SHADOW DEPTH



PAINTED RIBBON ELEMENT  
(FLAT ON WALL)



PAINTED NOTES ELEMENT  
(FLAT ON WALL)

## MATERIALS & CONSTRUCTION

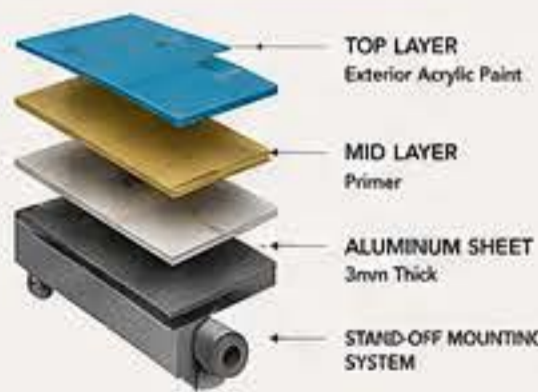

- Aluminum Sheet Panels (3mm thick)
- Painted with Premium Exterior Acrylic Paints
- Bonding Primer for Aluminum
- Concealed Mechanical Fastening to Wall with Stand-offs
- Durable for Wisconsin Climate
- Marine Grade Stainless Steel Hardware
- Multiple Layers for Depth (1" – 2" off wall)

## TYPICAL PANEL MOUNTING DETAIL

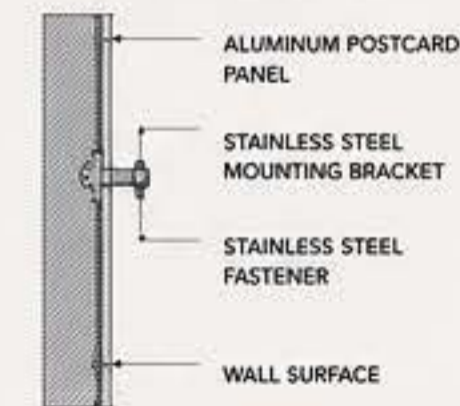

## FINISH

- UV Resistant
- Anti-Graffiti Clear Coat
- Weather Resistant
- Durable for Wisconsin Climate

## COLOR PALETTE



## EXPERIENCE + IMPACT



Photo Destination



Walkable Storytelling Experience



Celebrates Local Identity



Supports Downtown Waukesha



Durable & Maintainable



Family Friendly

*Activating Friedman Alley as a vibrant, artistic and memorable destination.*

## COMMUNITY CONNECTION

The Fox River serves as both a physical and symbolic thread throughout the artwork, connecting Waukesha's history, music heritage, downtown district, and future aspirations. The oversized postcards invite residents and visitors to rediscover the stories that make Waukesha unique.

## ABOUT TILT VISION ART

Brad Smith and Kay Ray are artists and muralists with more than 40 years of experience creating art that transforms spaces and strengthens communities.

# Tilt Vision Art

## Threads of Waukesha

### Budget & Scope of Work

#### Project Summary

Threads of Waukesha is a public art installation proposed for Friedman Alley at the Thomas Press Building. The project features five oversized aluminum postcard panels integrated into a painted mural composition. Flowing painted ribbons and musical elements connect themes celebrating the Fox River, Historic Downtown, Waukesha's music heritage, arts and culture, and community identity.

#### Project Scope

- Concept development and final artwork design
- Fabrication coordination for five aluminum postcard panels
- Mounting hardware and installation planning
- Surface preparation and mural painting
- Painted ribbon system integrated with existing architecture
- Protective anti-graffiti coating
- Travel, lodging, project management, and installation

#### Proposed Budget

Design & Planning: \$6,000

Project Management: \$2,500

Aluminum Postcard Fabrication: \$7,500

Mounting Hardware & Brackets: \$1,500

Paints, Primers & Materials: \$2,500

Lift Rental & Equipment: \$2,000

Travel: \$2,000

Lodging: \$3,000

Per Diem / Meals: \$1,500

Installation Labor: \$3,500

Mural Painting Labor: \$15,000

Anti-Graffiti Protective Coating: \$1,500

Contingency: \$500

**Total Project Budget: \$45,000**

## **Project Schedule**

Final Design Development & City Review: 2–3 Weeks  
Fabrication of Aluminum Postcard Panels: 3–4 Weeks  
Surface Preparation & Site Coordination: 1 Week  
Painting & Installation: 2–3 Weeks  
Final Touches & Protective Coatings: 2–3 Days

**Estimated Total Duration: 8–12 Weeks Following Contract Approval and Final Design Authorization**

*Submitted by Brad Smith & Kay Ray | Tilt Vision Art | Houston, Texas*

817-703-8141 | [tiltvision.art@protonmail.com](mailto:tiltvision.art@protonmail.com) | [www.tiltvision.art](http://www.tiltvision.art)



# City of Garland Street Department

Garland, Texas | Civic mural honoring the people, infrastructure, and public works professionals who help build and maintain the city.



# Magnolia RV Resort

Waco, Texas | Destination mural highlighting regional landmarks, travel heritage, and iconic Texas imagery.



# Historic Burleson Mural

Burleson, Texas | Community heritage mural celebrating the city's railroad roots and historic development.



## Near Southside Public Art

Fort Worth, Texas | Large-scale district mural contributing to the visual identity and revitalization of the Near Southside arts district.





Economic  
Development

August 25, 2022

To whom it may concern,

It is uncommon for anyone in our community to not know the name of Brad Smith. Local artist Brad Smith is well known and highly respected by business owners, city leaders, and citizens of Burleson because of the enthusiasm and creativity he puts into his work to make our city stand out from the rest.

The murals he has painted throughout our great city are well known to most. His hand painted murals have been photo backdrops for families for decades, the main topic of discussion at locally hosted art centered events, as well as being frequently used in various publications highlighting attractions throughout the City of Burleson.

Multiple murals that exist on the sides of brick and mortar buildings in our downtown district predate the recent revitalization of the district as a whole. We strongly believe Brad's artwork played a vital role in restoring a part of our city that was in dire need of redevelopment.

Brad's contributions to our city will be appreciated for decades to come, by generations to come. We are eternally grateful for the huge impact he has made on our community.

Sincerely,

A handwritten signature in black ink that reads "Joni Van Noy". The signature is written in a cursive, flowing style.

Old Town Administrator, Economic Development



December 24, 2024

To Whom It May Concern,

I am writing to highly recommend Brad and Kay Ray Smith of Tilt Vision for any artistic or mural project. They recently completed an exceptional 7-foot-tall by 23-foot-wide mural for our new Street Department Facility, and their work has left a lasting impression on everyone who sees it.

Brad and Kay dedicated themselves to thoroughly researching the history of Garland's Street Department, including the equipment and tools used by our staff in the field. This commitment to understanding our work allowed them to create a dynamic and meaningful mural for our conference room, one that beautifully integrates iconic buildings from Garland with incredible attention to detail.

Their unique **Retro Futurism Style**, which caught the attention of our panel during the selection process, has resulted in a one-of-a-kind piece that is both contemporary and timeless. The mural was meticulously hand-painted on canvas in their studio before being professionally installed and framed on-site. Throughout the process, they demonstrated a remarkable ability to incorporate our feedback, ensuring that all of our requests were seamlessly integrated into the final design.

Working with Tilt Vision was a pleasure. Their passion for their craft, coupled with their collaborative approach and technical expertise, resulted in an extraordinary piece of art that will inspire and impress for years to come.

I am confident that Brad and Kay Ray Smith will bring the same level of dedication, creativity, and professionalism to any future project. If you have the opportunity to work with them, I am certain you will be as impressed as we are.

Should you have any questions or require additional information, please feel free to contact me.

Sincerely,

A handwritten signature in black ink that reads "Amy Rosenthal". The signature is written in a cursive, flowing style.

Amy Rosenthal  
City of Garland, TX – Cultural Arts Director  
arosenthal@garlandtx.gov  
Cell: 817-269-1326



1606 MISTLETOE BLVD.  
FORT WORTH, TEXAS 76104  
817.923.1649  
NEARSOUTHSIDFW.ORG

#### BOARD OF DIRECTORS

Shelby Anderson  
Paul Ballard  
Councilmember Elizabeth Beck  
Hayden Blackburn  
Chuck Bouigny\*  
Kristen Camareno  
Katrina Carpenter  
José Castro  
Richard Cervenka  
Jack Clark\*  
Bruce Davis  
Marty Englander  
Colleen Fischer\*  
Mike Fisher  
Reginald Gates  
Bobby Grigsby\*  
Jennifer Grissom  
Jeff Guinn  
Jennifer Henderson\*  
John Hoover  
Tina Howard\*  
Henry Hudson  
Nicole Hunter  
Bob Jameson  
Ginger Johnson  
Mark Lucas Kelly  
Chad Kerr\*  
Casey Kha  
Tareka Lofton  
Roxanne Martinez  
Bobby Mays  
Noe Neaves  
Councilmember Chris Nettles  
Will Northern  
Stacey Portnoy  
Charlie Powell  
Ryon Price  
Gaye Reed  
Samantha Renz  
Jake Richter  
Shinna Saldaña  
Michael Sanborn\*  
Ken Schaefer\*  
Amanda Schulte  
Spencer Seals  
William Seegei  
Brent Sparks  
Robert Sturms  
Andy Taft  
Martin Thompson  
Robbie Werner  
Jason Williamson\*  
Corey Wilson  
Jeff Wood

Executive Committee\*

To whom it may concern,

Fort Worth's Near Southside is one of the largest State Designated Cultural District in Texas, proudly boasting more than 1,400 acres of live music, theater, restaurants, nightlife, and arts spaces. In the earliest days of our district's renaissance, our organization was tasked with amplifying the existing cultural voice of our community. Supporting artists while balancing the historic preservation and economic redevelopment initiatives outlined for the future was no easy task.

We were fortunate to have the partnership and creativity of Brad Smith and his television art collaborative as our ally in the cause. Brad's thoughtful artistic narratives drew attention to the identity of our eclectic community. Drawing from the stories of our community, his murals blended classic American iconography with Near Southside people and places. Partnering with the district's property owners resulted in the addition of many high-quality artworks that today are cherished as recognizable Near Southside icons. The brightly-colored murals Brad delivered also signaled a change for outsider perceptions of our once economically depressed district.

When the general public to our area, these whimsical depictions of Americana repositioned the neighborhood as an inviting and culturally-vibrant space. The artwork is both relatable at first glance and community-specific as viewers take a deeper dive into the content. As the public returned for casual interactions in the area like dinner and a show, we also saw an increasing number of people willing to make more significant investments such as living and working in the Near Southside.

Throughout the projects he has undertaken, Brad's professionalism in working alongside developers, residents, and other various stakeholders has shined through. Always agreeable, Brad is a collaborative artist who appreciates feedback, embraces conversation, and delivers as promised.

Our Near Southside cultural district has greatly benefitted from our partnership with Brad. His murals continue to draw attention to our district's retail and residential spaces. We highly recommend Brad Smith's services to other communities seeking public art investments.

Sincerely  
Megan Henderson  
DIRECTOR OF EVENTS +  
COMMUNICATIONS  
cell 817.966.1880  
megan@nearsouthsidefw.org